



Mercury
PR0710-MON



Intuitive
PR0750-MON

Mercury 2 & Intuitive Mercury Monitor Installation & User Guide



Resource Data Management Ltd
80 Johnstone Avenue, Hillington Industrial Estate,
Glasgow, Scotland G52 4NZ UK
☎ +44(0)141 810 2828 Switchboard
✉ support@resourcedm.com Technical Support
✉ sales@resourcedm.com Sales Enquiries



Table of Contents:

THE MERCURY & INTUITIVE 6 INPUT MONITOR 4

Description 4

 Variants 4

Configuration 4

Compatible Network Interfaces 4

Front Display Features 5

Connections 5

Mercury Mk2 5

Intuitive Mercury Controller Intuitive Mercury Network Expansion Options 6

Input and Output Allocation Tables 6

 Input allocation table 6

 Switched Resistor Values 7

 Relay Output allocation table 7

Remote Relays 7

Setting up the controller 7

 Setup through front buttons 7

 Setup Function Menu (Common to all types)..... 8

Recommended set-up method 8

 rtc. Real time clock (This will automatically synchronise on network systems) 8

 type. Set/view controller type 8

 Unit. Set/view temperature unit and Probe type 8

 PArA. Set/view parameters (This can be achieved at the network front end) 9

Parameter Tables (Types 1&3) 9

 Parameter table for Probe Tester (Type 2) 10

 Parameter Description 11

Network Configuration 12

 RS485 Legacy module / Intuitive Internal RS485 Network card 12

 Wireless Mesh Communication Module 12

 Fast Network Address Reset 12

 IP Futura module / Intuitive Internal IP Network card 12

Mercury Switch 13

Normal Operation 13

 Defrost (Type 1 only)..... 14

 Defrost Over-run (Type 1 only) 14

 Faults..... 14

 Network 14

 Probe Offset 14

 Inhibit Alarms (Type 1 only) 14

 Alarm Relay Action:..... 14

Viewing 15

Input / Output Table 15

Display Messages 16

Network Alarms 16

 Probe Offset 16

Specification 17

 Power requirements 17

 General..... 17

 Relay Specification..... 17

 Inputs..... 18

Switched Resistor Example Wiring 18

Installation 18

Dimensions 18

 Fixing 18

Dimensions 19

 Intuitive Mercury Mounting Instructions 19

 Cleaning 19



Ensure that all power is switched off before installing or maintaining this product

Disclaimer 19

REVISION HISTORY..... 20



Ensure that all power is switched off before installing or maintaining this product

The Mercury & Intuitive 6 Input Monitor

From Resource Data Management

Description

The Mercury 2 & intuitive Mercury Monitor have three controller types embedded in one controller. Type one is a 6-channel temperature monitor with defrost inputs to inhibit alarms. Each input can be configured for temperature probe or plant fault (either N/C or N/O). Each channel can be independently configured for over and under temperature alarm set points as well as alarm and recovery delays. The Monitor can also be configured as a temperature probe tester, where the monitor simply records the values without generating alarms. The third type of controller can be used for monitoring in low temperature applications with over and under temperature alarm limits for each channel. Channels can also be configured for plant faults (either N/C or N/O). The Monitor can operate stand-alone or be networked through either "legacy 485" or "IP" network modules.

The Intuitive Mercury range is designed to be used in a control panel or electrical tray. This range has the same features as the Mercury Mk2 controller with additional benefits such as higher rated relays each protected by an integral fuse and fuse protection for the incoming power supply, all connections are plug and socket. There are multiple network interfaces to choose from including Ethernet.

The monitor supports PT1000, NTC2K, NTC470R, NTC700R, NTC3K, NTC2K25, NTC5K, NTC6K, NTC10K and NTC10K (2) temperature probes (Note: All 6 inputs must be the same type, they cannot be mixed)

Each input can be configured to have a temperature offset to compensate for long cable lengths.

Variants

Description	Part Number
Mercury Mk2, 6 Channel Monitor	PR0710-MON
Intuitive Mercury, 6 Channel Monitor	PR0750-MON

Configuration

The controller is delivered pre-configured as a Temperature Monitor (Type 1)

The controller gives three configuration options: (see [set-up](#) for changing the type)

Display value	Type M
1	6 channel temperature or fault monitor
2	6 channel probe tester
3	6 channel Low temperature monitor

Compatible Network Interfaces

Mercury and Intuitive Mercury controllers are capable of connecting either to a TCP/IP local area network, an RS485 Genus compatible network, an RDM wireless mesh network or they can be used in standalone mode with no network output. To connect to a network you must add the correct communications module. Connecting to any of these communication modules will automatically be detected on power up and will affect the set up screens available to you.

Description	Part Number
IP Futura (Single Mercury to IP Interface)	PR0016
RS485 Interface (Single Mercury to RS485 Interface)	PR0026
Mercury IP Switch (IP support for 10 controllers)	PR0018
Mercury IP Switch with Pressure/Humidity Inputs	PR0018-PHI
Wireless Mesh Interface (for single Mercury)	PR0730

The Intuitive Mercury Controller is supplied as standard with an internal RS232 network card, this allows connection to any of the above external network interfaces. Three alternative internal network cards are also available, these can be supplied factory fitted as an option or purchased separately as an interface kit.

Description	Part Number
Intuitive Internal IP Network Card Interface Kit	PR0770
Intuitive Internal RS485 Network Card Interface Kit	PR0771
Intuitive Internal Wireless Mesh Network Card Interface Kit	PR0772



Ensure that all power is switched off before installing or maintaining this product

Front Display Features

LED's: -

Valve (Not Used) 

Fans (Not Used) 

Lights (Not Used) 

Defrost (Relay 2) 

On-Line 

- Off No network attached
- Flashing Attempting to Log on to network
- Steady On-line

Service (Not Used) 

Alarm (Relay 1) 

HACCP (Not Used) 



Keys

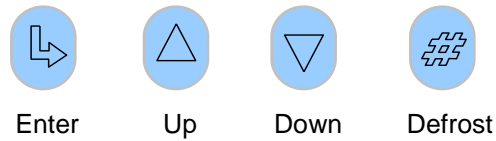

Note: Function keys illuminate when pressed, illumination is turned off 20 seconds after the key is used. Press and hold the defrost button to force a manual defrost

Main Display



4 character LED display, used to display time and status messages.

Note the Intuitive Mercury display is Green in colour when lit.

Connections

Mercury Mk2

Input and Output connections are made to the back of the controller, the RS232 communication port is on the side. The diagram shows the connection detail. Inputs and outputs are assigned according to the chosen configuration. See [Input/Output](#) tables for further details on connections.

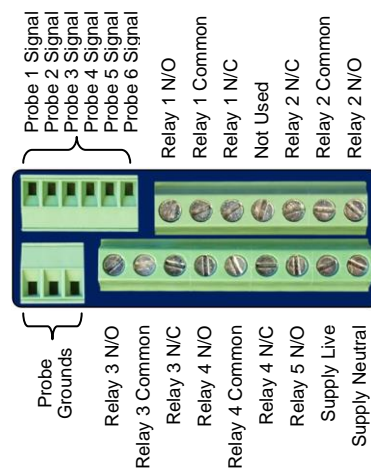

Do not connect an earth.



Ensure that all power is switched off before installing or maintaining this product

Intuitive Mercury Controller

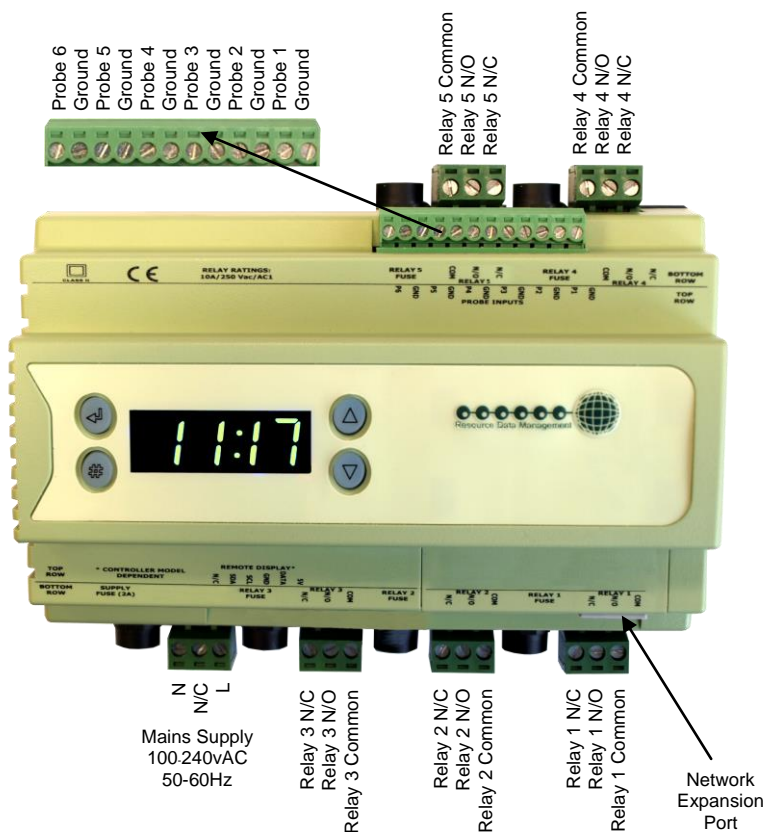

All inputs and outputs are plug and socket. The supply voltage and relay outputs have individual fuse protection.

Input and Output Allocation Tables

The following tables indicate; on a controller type basis, the functions of the inputs and outputs. Also shown are the defrost inputs that are derived by switching in a fixed value resistor across the input.

Input allocation table

	Monitor Type 1	Probe Tester Type 2	LT Monitor Type 3	Alarm Action Type 1&3	Alarm Action Type 2	Plant Input Type 1 (Switched Resistors)	Plant Input Type 2 & 3 (Switched Resistors)
Probe 1	Probe 1 or Plant Fault	Probe 1	Probe 1 or Plant Fault	Yes	N/A	Defrost Signal 1	N/A
Probe 2	Probe 2 or Plant Fault	Probe 2	Probe 2 or Plant Fault	Yes	N/A	Defrost Signal 2	N/A
Probe 3	Probe 3 or Plant Fault	Probe 3	Probe 3 or Plant Fault	Yes	N/A	Defrost Signal 3	N/A
Probe 4	Probe 4 or Plant Fault	Probe 4	Probe 4 or Plant Fault	Yes	N/A	Defrost Signal 4	N/A
Probe 5	Probe 5 or Plant Fault	Probe 5	Probe 5 or Plant Fault	Yes	N/A	Defrost Signal 5	N/A
Probe 6	Probe 6 or Plant Fault	Probe 6	Probe 6 or Plant Fault	Yes	N/A	Defrost Signal 6	N/A

Intuitive Mercury Network Expansion Options

RS232 Network Card (Default)

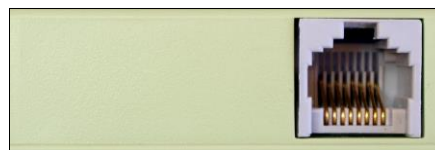

The Intuitive Mercury is supplied with an RS232 Network Card fitted as standard. Some example optional network cards are shown below

IP Network Card (PR0770)



Rotary Address Switches
Network Collision LED
Network Activity LED

RS485 Network Card (PR0771)



Ground B- A+ Screen
Network Activity LED

PR0772 Wireless Mesh Option also available. The network interfaces work in the same way as there external counterparts.



Ensure that all power is switched off before installing or maintaining this product

Switched Resistor Values

- For PT1000 probes use 820 Ohm
- For NTC2K, NTC2K25 and NTC3K probes use 590 Ohm
- For NTC5K and NTC 6K probes use 1K Ohm
- For NTC10k probes use 2K7 resistors
- For NTC10 (2) probes use 2K Ohm

The resistors used must have a tolerance of 1% or better and the resistor must have a power rating of 0.25W. For improved accuracy whilst using switched resistors RDM recommend resistors with 0.1% accuracy are used. When a resistor is switched across the appropriate input it signals to the Mercury a defrost on that channel whilst still recording the probe temperature on the input.

Relay Output allocation table

	Monitor Type 1	Probe Tester Type 2	LT Monitor Type 3	Relay Action Type 1 & 3	Relay Action Type 2
Relay 1	Alarm*	Not Used	Alarm*	Output OK = Relay Energised	Not Used
Relay 2	Any Channel On Defrost	Not Used	Remote Relay 1	Output Off = Relay Energised	Not Used
Relay 3	Remote Relay 1	Not Used	Remote Relay 2	Output Off = Relay Energised	Not Used
Relay 4	Remote Relay 2	Not Used	Remote Relay 3	Output Off = Relay De Energised	Not Used
Relay 5	Remote Relay 3	Not Used	Remote Relay 4	Output Off = Relay De Energised	Not Used

*The alarm relay is energised for no alarm. Use the NC and Common for “Loop make” on alarm or use the NO and Common for “Loop break” on alarm

Remote Relays

Relays outlined as “Remote relay” can be used as remote relays by the Data Builder and GP Timer. Refer to the appropriate guide for further information.

Text strings for remote relay use: -

Relay	Use text string (Data Builder)	Gp Timer (General) Output Channel
1	Remote relay ?	0
2	Remote relay ?	1
3	Remote relay ?	2
4	Remote relay ?	3
5	Remote relay ?	4

Where “?” is determined by the controller type selected

Setting up the controller

Access to the controller can be achieved several ways

- Through the front mounted buttons
- Direct access by PC or palm top into the rear comms port. This requires a software package available on the RDM website
- Through legacy front end panels on 485 networks
- Through the RDM Data Manager.
- Across an IP network. (Current controller IP address required)

Setup through front buttons



To enter setup mode, hold the Enter and Down buttons together for approximately 3 seconds until the message “Ent” appears on the display. Now press the Enter button again to enter the function menu. IO will be displayed. Scroll up or down to go through the list.



Ensure that all power is switched off before installing or maintaining this product

Setup Function Menu (Common to all types)

Display	Option	Explained in Paragraph	Display	Option	Explained in Paragraph
IO	View Inputs / Outputs and States	Input / output table	inh1	Inhibit Channel 1*	Inhibit channel
PArA	Set/View Parameters	Set view parameters	inh2	Inhibit Channel 2*	Inhibit channel
Unit	Probe type and Celsius/Fahrenheit option	Set View Unit	inh3	Inhibit Channel 3*	Inhibit channel
tyPE	Set/View Controller Type	Set/view controller type	inh4	Inhibit Channel 4*	Inhibit channel
Rtc	Set/view Clock (rtc = Real Time Clock)	Real Time Clock	inh5	Inhibit Channel 5*	Inhibit channel
nEt	Set/view network configuration	Network Configuration	inh6	Inhibit Channel 6*	Inhibit channel
SoFt	View software version				
OFSt	Probe Offset	Probe Offset	ESC	Exit Setup mode	

* Inhibit function available in type 2 only.

Recommended set-up method

If you are not connecting to a network and want to set up the controller through the buttons we recommend you use the following order from the function menu.

rtc. Real time clock (This will automatically synchronise on network systems)

- Use the up or down buttons to scroll through the display until the display reads "rtc"
- Press enter. The display will show "t-1". press enter again
- Scroll hours up or down (0 – 23) press enter
- Use up button to select "t-2", press enter
- Scroll minutes up or down (0 – 59) press enter
- Repeat for t-3 (seconds 0 – 59)
- Repeat for t-4 (Days up to 31)
- Repeat for t-5 (months up to 12)
- Repeat for t-6 (Year up to 99)
- Use up button to display "ESC", press enter to display "rtc"

Time clock is now set

type. Set/view controller type

- From the function menu scroll to select type, press enter
- Use the up/down buttons to scroll through case/coldroom configuration types. (see [configuration table on](#) page 4)
- Press enter.
- Scroll to select "ESC"
- Press enter

Controller type configuration is now set

Unit. Set/view temperature unit and Probe type

From the function menu scroll to select Unit
Press enter and the value will be displayed: -

Change the probe type to: - Type 1 & 2

0 = PT1000 °C	Range -42.0 to 128.0 °C
1 = PT1000 °F	Range -43.6 to 262.4 °F
2 = NTC2K °C	Range -42.0 to 60.0 °C
3 = NTC2K °F	Range -43.6 to 140.0 °F
4 = NTC470R °C	Range -42.0 to 45.0 °C
5 = NTC470R °F	Range -43.6 to 114.0 °F
6 = NTC700R °C	Range -42.0 to 60.0 °C
7 = NTC700R °F	Range -43.6 to 140.0 °F
8 = NTC3K °C	Range -42.0 to 60.0 °C
9 = NTC3K °F	Range -43.6 to 140.0 °F
10 = NTC2K25 °C	Range -42.0 to 58 °C
11 = NTC2K25 °F	Range -43.6 to 136.3 °F
12 = NTC5K °C	Range -42.0 to 60.0 °C
13 = NTC5K °F	Range -43.6 to 140.0 °F
14 = NTC6K °C	Range -42.0 to 60.0 °C
15 = NTC6K °F	Range -43.6 to 140.0 °F
16 = NTC10K °C	Range -42.0 to 60.0 °C
17 = NTC10K °F	Range -43.6 to 140.0 °F
18 = NTC10K(2) °C	Range -42.0 to 60.0 °C
19 = NTC10K(2) °F	Range -43.6 to 140.0 °F

Type 3

Range -98.0 to 128.0 °C
Range -144.4 to 262.4 °F
Range -98.0 to 106.0 °C
Range -144.4 to 223.0 °F
Range -98.0 to 45.0 °C
Range -144.4 to 114.0 °F
Range -42.0 to 60.0 °C
Range -41.1 to 140.0 °F
Range -98.0 to 100.0 °C
Range -144.4 to 212.0 °F
Range -98.0 to 90.0 °C
Range -144.0 To 194.0 °F
Range -98.0 to 118.0 °C
Range -144.0 to 245.0 °F
Range -98.0 to 125.0 °C
Range -144.0 to 258.0 °F
Range -98.0 to 128.0 °C
Range -144.0 To 262.4 °F
Range -85.6 to 128.0 °C
Range -122.2 to 262.4 °F



Ensure that all power is switched off before installing or maintaining this product

PArA. Set/view parameters (This can be achieved at the network front end)

- a. From the function menu scroll to select PArA
- b. Pressing Enter while PArA is displayed will enter the parameter menu. The first parameter option will be displayed as P-01. Pressing the Up or Down button will present the other parameter options P-02, P-03 etc. See the parameter list below to find what parameter number corresponds to which actual parameter. Pressing the Enter button will show the current value of the selected parameter. Press Up or Down to modify the value and press Enter again to save the value. The parameter list number will be displayed again. Two other options are present in the parameter menu – dFLt and ESC. Selecting ESC will exit setup mode. Selecting dFLt will reset all parameters back to the default values for the current type of controller.

Parameter Tables (Types 1&3)

Not all parameters apply to all controller types, for example P-08 is Channel 1 Defrost Over-run which only applies to Monitor type 1, this parameter will not appear if the controller is set up as a type 3 (Low temperature monitor). In the following table, the type columns on the right hand side will be greyed out if that parameter does not apply to that controller type.

Number	Parameter	Range °C (°F)	Step	Units	Default °C (°F)	Monitor Type 1	LT Monitor Type 3
P-01	Channel 1 Select	0 (Off), 1 (Probe), 2 (Plant N/C), 3 (Plant N/O)			1	✓	✓
P-02	C1 Slug Probe	0 (No), 1 (Yes)			0	✓	✓
P-03	Channel 1 UT	-42.0 – 128.0°C (-43.6 – 262.4°F)	0.1	Deg	-2.0 (28.4)	✓	
	Channel 1 UT	-98.0 – 128.0°C (-144.4 – 262.4°F)	0.1	Deg	-2.0 (28.4)		✓
P-04	Channel 1 OT	-42.0 – 128.0°C (-43.6 – 262.4°F)	0.1	Deg	5.0 (41.0)	✓	
	Channel 1 OT	-98.0 – 128.0°C (-144.4 – 262.4°F)	0.1	Deg	5.0 (41.0)		✓
P-05	C1 Alarm Delay	00:00 to 99:00	01:00	mm:ss	20:00	✓	✓
P-06	C1 Recovery	00:00 to 99:00	01:00	mm:ss	20:00	✓	
P-07	C1 Inhibit	00:00 to 99:00	01:00	mm:ss	30:00	✓	
P-08	C1 Defrost Over-run	00:00 to 99:00	01:00	mm:ss	60:00	✓	
P-11	Channel 2 Select	0 (Off), 1 (Probe), 2 (Plant N/C), 3 (Plant N/O)			1	✓	✓
P-12	C2 Slug Probe	0 (No), 1 (Yes)			0	✓	✓
P-13	Channel 2 UT	-42.0 – 128.0°C (-43.6 – 262.4°F)	0.1	Deg	-2.0 (28.4)	✓	
	Channel 2 UT	-98.0 – 128.0°C (-144.4 – 262.4°F)	0.1	Deg	-2.0 (28.4)		✓
P-14	Channel 2 OT	-42.0 – 128.0°C (-43.6 – 262.4°F)	0.1	Deg	5.0 (41.0)	✓	
	Channel 2 OT	-98.0 – 128.0°C (-144.4 – 262.4°F)	0.1	Deg	5.0 (41.0)		✓
P-15	C2 Alarm Delay	00:00 to 99:00	01:00	mm:ss	20:00	✓	✓
P-16	C2 Recovery	00:00 to 99:00	01:00	mm:ss	20:00	✓	
P-17	C2 Inhibit	00:00 to 99:00	01:00	mm:ss	30:00	✓	
P-18	C2 Defrost Over-run	00:00 to 99:00	01:00	mm:ss	60:00	✓	
P-21	Channel 3 Select	0 (Off), 1 (Probe), 2 (Plant N/C), 3 (Plant N/O)			1	✓	✓
P-22	C3 Slug Probe	0 (No), 1 (Yes)			0	✓	✓
P-23	Channel 3 UT	-42.0 – 128.0°C (-43.6 – 262.4°F)	0.1	Deg	-2.0 (28.4)	✓	
	Channel 3 UT	-98.0 – 128.0°C (-144.4 – 262.4°F)	0.1	Deg	-2.0 (28.4)		✓
P-24	Channel 3 OT	-42.0 – 128.0°C (-43.6 – 262.4°F)	0.1	Deg	5.0 (41.0)	✓	
	Channel 3 OT	-98.0 – 128.0°C (-144.4 – 262.4°F)	0.1	Deg	5.0 (41.0)		✓
P-25	C3 Alarm Delay	00:00 to 99:00	01:00	mm:ss	20:00	✓	✓
P-26	C3 Recovery	00:00 to 99:00	01:00	mm:ss	20:00	✓	
P-27	C3 Inhibit	00:00 to 99:00	01:00	mm:ss	30:00	✓	
P-28	C3 Defrost Over-run	00:00 to 99:00	01:00	mm:ss	60:00	✓	
P-31	Channel 4 Select	0 (Off), 1 (Probe), 2 (Plant N/C), 3 (Plant N/O)			1	✓	✓
P-32	C4 Slug Probe	0 (No), 1 (Yes)			0	✓	✓
P-33	Channel 4 UT	-42.0 – 128.0°C (-43.6 – 262.4°F)	0.1	Deg	-2.0 (28.4)	✓	
	Channel 4 UT	-98.0 – 128.0°C (-144.4 – 262.4°F)	0.1	Deg	-2.0 (28.4)		✓
P-34	Channel 4 OT	-42.0 – 128.0°C (-43.6 – 262.4°F)	0.1	Deg	5.0 (41.0)	✓	
	Channel 4 OT	-98.0 – 128.0°C (-144.4 – 262.4°F)	0.1	Deg	5.0 (41.0)		✓
P-35	C4 Alarm Delay	00:00 to 99:00	01:00	mm:ss	20:00	✓	✓
P-36	C4 Recovery	00:00 to 99:00	01:00	mm:ss	20:00	✓	
P-37	C4 Inhibit	00:00 to 99:00	01:00	mm:ss	30:00	✓	
P-38	C4 Defrost Over-run	00:00 to 99:00	01:00	mm:ss	60:00	✓	



Ensure that all power is switched off before installing or maintaining this product

P-41	Channel 5 Select	0 (Off), 1 (Probe), 2 (Plant N/C), 3 (Plant N/O)			1	✓	✓
P-42	C5 Slug Probe	0 (No), 1 (Yes)			0	✓	✓
P-43	Channel 5 UT	-42.0 – 128.0°C (-43.6 – 262.4°F)	0.1	Deg	-2.0 (28.4)	✓	
	Channel 5 UT	-98.0 – 128.0°C (-144.4 – 262.4°F)	0.1	Deg	-2.0 (28.4)		✓
P-44	Channel 5 OT	-42.0 – 128.0°C (-43.6 – 262.4°F)	0.1	Deg	5.0 (41.0)	✓	
	Channel 5 OT	-98.0 – 128.0°C (-144.4 – 262.4°F)	0.1	Deg	5.0 (41.0)		✓
P-45	C5 Alarm Delay	00:00 to 99:00	01:00	mm:ss	20:00	✓	✓
P-46	C5 Recovery	00:00 to 99:00	01:00	mm:ss	20:00	✓	
P-47	C5 Inhibit	00:00 to 99:00	01:00	mm:ss	30:00	✓	
P-48	C5 Defrost Over-run	00:00 to 99:00	01:00	mm:ss	60:00	✓	
P-51	Channel 6 Select	0 (Off), 1 (Probe), 2 (Plant N/C), 3 (Plant N/O)			1	✓	✓
P-52	C6 Slug Probe	0 (No), 1 (Yes)			0	✓	✓
P-53	Channel 6 UT	-42.0 – 128.0°C (-43.6 – 262.4°F)	0.1	Deg	-2.0 (28.4)	✓	
	Channel 6 UT	-98.0 – 128.0°C (-144.4 – 262.4°F)	0.1	Deg	-2.0 (28.4)		✓
P-54	Channel 6 OT	-42.0 – 128.0°C (-43.6 – 262.4°F)	0.1	Deg	5.0 (41.0)	✓	
	Channel 1 OT	-98.0 – 128.0°C (-144.4 – 262.4°F)	0.1	Deg	5.0 (41.0)		✓
P-55	C6 Alarm Delay	00:00 to 99:00	01:00	mm:ss	20:00	✓	✓
P-56	C6 Recovery	00:00 to 99:00	01:00	mm:ss	20:00	✓	
P-57	C6 Inhibit	00:00 to 99:00	01:00	mm:ss	30:00	✓	
P-58	C6 Defrost Over-run	00:00 to 99:00	01:00	mm:ss	60:00	✓	
dflt							

Parameter table for Probe Tester (Type 2)

Number	Parameter	Range	Step	Units	Default
P-81	Channel 1 select	0 (Off), 1 (ON)			1
P-82	Channel 2 select	0 (Off), 1 (ON)			1
P-83	Channel 3 select	0 (Off), 1 (ON)			1
P-84	Channel 4 select	0 (Off), 1 (ON)			1
P-85	Channel 5 select	0 (Off), 1 (ON)			1
P-86	Channel 6 select	0 (Off), 1 (ON)			1



Ensure that all power is switched off before installing or maintaining this product

Parameter Description

Number	Parameter	Description
P-01	Channel 1 Select	0 = Channel not used. 1 = Temperature probe 2 = No 0 volt return = alarm. 3 = 0 volt return = alarm
P-02	C1 Slug Probe	Electronic slugging
P-03	Channel 1 UT	Under temperature alarm
P-04	Channel 1 OT	Over temperature alarm
P-05	C1 Alarm Delay	Alarm delay period
P-06	C1 Recovery	Defrost recovery period
P-07	C1 Inhibit	Inhibit alarms
P-08	C1 Defrost Over-run	Defrost Over-run
P-11	Channel 2 Select	0 = Channel not used. 1 = Temperature probe 2 = No 0 volt return = alarm. 3 = 0 volt return = alarm
P-12	C2 Slug Probe	Electronic slugging
P-13	Channel 2 UT	Under temperature alarm
P-14	Channel 2 OT	Over temperature alarm
P-15	C2 Alarm Delay	Alarm delay period
P-16	C2 Recovery	Defrost recovery period
P-17	C2 Inhibit	Inhibit alarms
P-18	C2 Defrost Over-run	Defrost Over-run
P-21	Channel 3 Select	0 = Channel not used. 1 = Temperature probe 2 = No 0 volt return = alarm. 3 = 0 volt return = alarm
P-22	C3 Slug Probe	Electronic slugging
P-23	Channel 3 UT	Under temperature alarm
P-24	Channel 3 OT	Over temperature alarm
P-25	C3 Alarm Delay	Alarm delay period
P-26	C3 Recovery	Defrost recovery period
P-27	C3 Inhibit	Inhibit alarms
P-28	C3 Defrost Over-run	Defrost Over-run
P-31	Channel 4 Select	0 = Channel not used. 1 = Temperature probe 2 = No 0 volt return = alarm. 3 = 0 volt return = alarm
P-32	C4 Slug Probe	Electronic slugging
P-33	Channel 4 UT	Under temperature alarm
P-34	Channel 4 OT	Over temperature alarm
P-35	C4 Alarm Delay	Alarm delay period
P-36	C4 Recovery	Defrost recovery period
P-37	C4 Inhibit	Inhibit alarms
P-38	C4 Defrost Over-run	Defrost Over-run
P-41	Channel 5 Select	0 = Channel not used. 1 = Temperature probe 2 = No 0 volt return = alarm. 3 = 0 volt return = alarm
P-42	C5 Slug Probe	Electronic slugging
P-43	Channel 5 UT	Under temperature alarm
P-44	Channel 5 OT	Over temperature alarm
P-45	C5 Alarm Delay	Alarm delay period
P-46	C5 Recovery	Defrost recovery period
P-47	C5 Inhibit	Inhibit alarms
P-48	C5 Defrost Over-run	Defrost Over-run
P-51	Channel 6 Select	0 = Channel not used. 1 = Temperature probe 2 = No 0 volt return = alarm. 3 = 0 volt return = alarm
P-52	C6 Slug Probe	Electronic slugging
P-53	Channel 6 UT	Under temperature alarm
P-54	Channel 6 OT	Over temperature alarm
P-55	C6 Alarm Delay	Alarm delay period
P-56	C6 Recovery	Defrost recovery period
P-57	C6 Inhibit	Inhibit alarms
P-58	C6 Defrost Over-run	Defrost Over-run



Ensure that all power is switched off before installing or maintaining this product

Network Configuration

The final section to setup is the network address. In all instances, this must be done before the controller is plugged into the site network. The controllers have an auto-initialise function, which will automatically log the device onto the site network. If the wrong address has been entered onto the network, you will have to reset the controller address by setting the address to 00-0, and then re-enter the correct address. (You may have to deregister the wrong address from the home system as well).

When logging a Mercury or Intuitive Mercury with an RS232 interface onto a network you must first connect the controller to a communications module, this is either a 485 Legacy, RDM Wireless Mesh system, IP Futura or Mercury Switch. When using an Intuitive Mercury controller, the controller has to have the correct network card fitted (see "compatible network interfaces"). For connection to a Mercury Switch (Hub) or an external network interface, the standard fitment RS232 network card is utilized.

RS485 Legacy module / Intuitive Internal RS485 Network card

Connecting an RS485 legacy Module or an Intuitive Internal RS485 network card to the controller will govern which set up screens are made available. Both modules support the "Genus" protocol only.

Display	Option
485t	485 Network Type
485A	485 Address/Name
gAdd	Show underlying network address assigned to controller
rLog	Re-log the controller back onto the network
CLrA	Clear the address/name from the controller
ESC	Exit network menu. N.B. this option must be selected to save any changes made in this menu

The 485t option shows a value representing the network type. The possible values are:

Value	Network Type
1	Genus compatible (all versions)
2	RDM Wireless Mesh System (Wireless Mesh)

The 485A option shows a value representing either the name of the controller in a Genus compatible or Wireless Mesh network.

Wireless Mesh Communication Module

RDM Wireless Mesh System, please refer to the RDM Wireless Mesh Communication Module user guide, which can be obtained from the RDM website, for information regarding connecting a controller to a Wireless Mesh network.

The value shown in 485A is of the form 05-6. This means the controller would try to log onto a Genus compatible or RDM Wireless Mesh network using the name 'RC05-6'.

The gAdd option displays (in hexadecimal format) the underlying network address assigned to the controller when it was logged onto the network.

The rLog option allows the controller to be logged back onto the network with its current name. The 'rLog' message will flash for confirmation. Press the Enter button to execute the command, Up or Down buttons to cancel.

Fast Network Address Reset

The CLrA option will clear out the network address and name in the controller. The 'CLrA' message will flash for confirmation. Press the Enter button to execute the command, Up or Down buttons to cancel.

To enter this mode, hold the Enter, Up and Down buttons together for approximately 3 seconds until the message CLrA appears on the display. CLrA is the first option in the menu consisting of the following options:

Display	Option
CLrA	Clear the address/name from the controller
ESC	Exit Setup mode

Pressing the Enter button to select the CLrA option will cause the 'CLrA' message to flash for confirmation, if the network type is set to Genus compatible. Press the Enter button to execute the command, Up or Down buttons to cancel. If the network type is not set to Genus compatible then the CLrA message will not flash and the ESC option can be used to exit the menu.

IP Futura module / Intuitive Internal IP Network card

In an IP system there are two options,

- IP-L
- IP-r

IP-L allows you to fix an IP address into the controller, which you would use when you are connecting the controllers onto a customer's local area network. This would allow the customer to view each controller using Internet Explorer

IP-r allows you to give each controller on the system a unique number. This number is then allocated a dynamic IP address by the system DHCP server (such as the RDM Data Manager or Data Director)



Ensure that all power is switched off before installing or maintaining this product

IP-L

To configure the communication module or network card for IP-L, set all three rotary switches to zero. The module should then be connected to the controller. In the case of an Intuitive Mercury controller where the network card is already fitted, the controller should be powered off, all three rotary switches set to zero and the controller powered on.

1. nEt. From the function menu you can now select nEt
 - Press enter and the display will show "IP-L", press enter
 - You can now set the address using the table below

Display	Option
IP-1	IP Address byte 1
IP-2	IP Address byte 2
IP-3	IP Address byte 3
IP-4	IP Address byte 4
nL	Network Mask Length
gt-1	Gateway Address byte 1
gt-2	Gateway Address byte 2
gt-3	Gateway Address byte 3
gt-4	Gateway Address byte 4
ESC	Exit network menu. N.B. this option must be selected to save any changes made in this menu

IP-r

To configure the communication module for IP-r, set the three rotary switches to give each controller a unique identifier. The module should then be connected to the controller and the network. In the case of an Intuitive Mercury controller where the network card is already fitted, the three rotary switches must be set when the controller is powered off, the controller should then be powered on to connect to the network.

2. nEt. From the function menu you can now select nEt
 - Press enter and the display will show "IP-r", press enter
 - You can now view only the address given by the DHCP server

To ease setup, a single network mask length value is used. If the address has been specified with a network mask value in dotted IP format e.g. 255.255.255.0 then the table below gives the conversion:

Mask	Length	Mask	Length	Mask	Length
		255.255.254.0	23	255.254.0.0	15
255.255.255.252	30	255.255.252.0	22	255.252.0.0	14
255.255.255.248	29	255.255.248.0	21	255.248.0.0	13
255.255.255.240	28	255.255.240.0	20	255.240.0.0	12
255.255.255.224	27	255.255.224.0	19	255.224.0.0	11
255.255.255.192	26	255.255.192.0	18	255.192.0.0	10
255.255.255.128	25	255.255.128.0	17	255.128.0.0	09
255.255.255.0	24	255.255.0.0	16	255.0.0.0	08

Mercury Switch

Please refer to the Mercury Switch user guide, which can be obtained from the RDM website, for information regarding connecting a controller to a network.

Normal Operation

During normal operation, the controller will display the current time, if there are no alarms and no defrost actions. If there is a current alarm(s) the time will alternate with the alarm status. If the Monitor is on a network and on-line, the green network LED will be on.



Ensure that all power is switched off before installing or maintaining this product

Defrost (Type 1 only)

If a defrost signal is received (switched resistor) the Monitor will indicate which channel is in the defrost state and the amber defrost LED will come on. All alarms on that channel will be inhibited during the time the resistor is switched in. Alarms will continue to be inhibited for the duration of the recovery period after the resistor is switched out. (Note: if the defrost over-run parameter is set to 00:00, the channel will remain in the defrost state until the resistor is removed).
When any channel is in a defrost state, the defrost relay is energised.

Defrost Over-run (Type 1 only)

A defrost over-run period can be set into the monitor on a per channel basis, if the defrost exceeds this period, the channel will revert to normal operations. Setting this parameter to 00:00 inhibits this function.

Faults

If a fault is detected, the Monitor will indicate the fault on the display and the red alarm LED will come on.

Network

The Network green LED flashes if the controller goes off-line or loses its given address.

Probe Offset

Each probe can be offset by up to ± 10 °C to compensate for long cable runs.

Inhibit Alarms (Type 1 only)

Probe alarms can be inhibited on a probe-by-probe basis by selecting the desired channel parameter in the set up mode and pressing "enter". This state can be changed back by repeating the above procedure. There is also a timeout function on the alarm inhibit (see parameter table for timeout values)

Note. If the channel temperature is **not** within the set alarm limits before the inhibit timeout has elapsed, the channel will stay inhibited and **not** give an alarm.

--xxx **Use this feature with caution** xxx--

Alarm Relay Action:

The alarm relay has its' common, NO and NC contact available for use.
This relay will normally be energised (no alarm) and be de-energised when an alarm occurs (after the alarm delay time-out)
The table below shows the Alarm relay action

State	Alarm Delay	Alarm Relay
Probe Fault	Fixed 10 Seconds	x
Channel Under temp	Variable (parameter)	✓
Channel Over temp	Variable (parameter)	✓
Plant Fault	Variable (parameter)	✓



Ensure that all power is switched off before installing or maintaining this product

Viewing

Apart from setting up the controller, you can also view the status of the inputs and outputs and controller states. From the function menu, select "I/O", press enter. You can now scroll through the IO table as set out below. Inputs and outputs that do not apply to a particular controller type will be greyed out.

Input / Output Table

Number	IO	Range °C (°F)	Step	Units	Type 1	Type 2	Type 3
I-01	Probe 1	-42.0 – 128.0°C (-43.6 – 262.4°F)	0.1	Deg	✓	✓	
	Probe 1	-98.0 – 128.0°C (-144.4 – 262.4°F)	0.1	Deg			✓
I-02	Probe 2	-42.0 – 128.0°C (-43.6 – 262.4°F)	0.1	Deg	✓	✓	
	Probe 2	-98.0 – 128.0°C (-144.4 – 262.4°F)	0.1	Deg			✓
I-03	Probe 3	-42.0 – 128.0°C (-43.6 – 262.4°F)	0.1	Deg	✓	✓	
	Probe 3	-98.0 – 128.0°C (-144.4 – 262.4°F)	0.1	Deg			✓
I-04	Probe 4	-42.0 – 128.0°C (-43.6 – 262.4°F)	0.1	Deg	✓	✓	
	Probe 4	-98.0 – 128.0°C (-144.4 – 262.4°F)	0.1	Deg			✓
I-05	Probe 5	-42.0 – 128.0°C (-43.6 – 262.4°F)	0.1	Deg	✓	✓	
	Probe 5	-98.0 – 128.0°C (-144.4 – 262.4°F)	0.1	Deg			✓
I-06	Probe 6	-42.0 – 128.0°C (-43.6 – 262.4°F)	0.1	Deg	✓	✓	
	Probe 6	-98.0 – 128.0°C (-144.4 – 262.4°F)	0.1	Deg			✓
I-11	Defrost 1	0 (Off), 1 (On)			✓		
I-12	Defrost 2	0 (Off), 1 (On)			✓		
I-13	Defrost 3	0 (Off), 1 (On)			✓		
I-14	Defrost 4	0 (Off), 1 (On)			✓		
I-15	Defrost 5	0 (Off), 1 (On)			✓		
I-16	Defrost 6	0 (Off), 1 (On)			✓		
I-21	Plant Fault 1	0 (Ok), 1 (Alarm)			✓		✓
I-22	Plant Fault 2	0 (Ok), 1 (Alarm)			✓		✓
I-23	Plant Fault 3	0 (Ok), 1 (Alarm)			✓		✓
I-24	Plant Fault 4	0 (Ok), 1 (Alarm)			✓		✓
I-25	Plant Fault 5	0 (Ok), 1 (Alarm)			✓		✓
I-26	Plant Fault 6	0 (Ok), 1 (Alarm)			✓		✓
O-01	Alarm Relay	0 (Off), 1 (On)			✓		✓
O-11	Defrost Relay	0 (Off), 1 (On)			✓		
O-21	Relay 3	0 (Off), 1 (On)			✓		✓
O-22	Relay 4	0 (Off), 1 (On)			✓		✓
O-23	Relay 5	0 (Off), 1 (On)			✓		✓
S-01	Control State 1	0 (Off), 1 (Stabilise), 2 (Normal), 3 (Defrost), 4 (Recovery), 5 (Alarm), 6 (Inhibit)			✓		
	Control State 1	0 (Off), 1 (Stabilise), 2 (Normal), 3 (Alarm),					✓
S-02	Control State 2	0 (Off), 1 (Stabilise), 2 (Normal), 3 (Defrost), 4 (Recovery), 5 (Alarm), 6 (Inhibit)			✓		
	Control State 2	0 (Off), 1 (Stabilise), 2 (Normal), 3 (Alarm),					✓
S-03	Control State 3	0 (Off), 1 (Stabilise), 2 (Normal), 3 (Defrost), 4 (Recovery), 5 (Alarm), 6 (Inhibit)			✓		
	Control State 3	0 (Off), 1 (Stabilise), 2 (Normal), 3 (Alarm),					✓
S-04	Control State 4	0 (Off), 1 (Stabilise), 2 (Normal), 3 (Defrost), 4 (Recovery), 5 (Alarm), 6 (Inhibit)			✓		
	Control State 3	0 (Off), 1 (Stabilise), 2 (Normal), 3 (Alarm),					✓
S-05	Control State 5	0 (Off), 1 (Stabilise), 2 (Normal), 3 (Defrost), 4 (Recovery), 5 (Alarm), 6 (Inhibit)			✓		
	Control State 5	0 (Off), 1 (Stabilise), 2 (Normal), 3 (Alarm),					✓
S-06	Control State 6	0 (Off), 1 (Stabilise), 2 (Normal), 3 (Defrost), 4 (Recovery), 5 (Alarm), 6 (Inhibit)			✓		
	Control State 6	0 (Off), 1 (Stabilise), 2 (Normal), 3 (Alarm),					✓



Ensure that all power is switched off before installing or maintaining this product

Display Messages

The following alarms and messages can appear on the Mercury display.

Display Message	System status
on	Controller On
Prb1	Probe 1 Fault
Prb2	Probe 2 Fault
Prb3	Probe 3 Fault
Prb4	Probe 4 Fault
Prb5	Probe 5 Fault
Prb6	Probe 6 Fault
Pd1	Control State in Recovery
Pd2	Control State in Recovery
Pd3	Control State in Recovery
Pd4	Control State in Recovery
Pd5	Control State in Recovery
Pd6	Control State in Recovery
deF1	Control State in Defrost
deF2	Control State in Defrost
deF3	Control State in Defrost
deF4	Control State in Defrost
deF5	Control State in Defrost
deF6	Control State in Defrost
Inh1	Inhibit alarms for probe 1
Inh2	Inhibit alarms for probe 2
Inh3	Inhibit alarms for probe 3

Display Message	System status
Inh4	Inhibit alarms for probe 4
Inh5	Inhibit alarms for probe 5
Inh6	Inhibit alarms for probe 6
Ot 1	Over Temperature Alarm probe 1
Ot 2	Over Temperature Alarm probe 2
Ot 3	Over Temperature Alarm probe 3
Ot 4	Over Temperature Alarm probe 4
Ot 5	Over Temperature Alarm probe 5
Ot 6	Over Temperature Alarm probe 6
Ut 1	Under Temperature Alarm probe 1
Ut 2	Under Temperature Alarm probe 2
Ut 3	Under Temperature Alarm probe 3
Ut 4	Under Temperature Alarm probe 4
Ut 5	Under Temperature Alarm probe 5
Ut 6	Under Temperature Alarm probe 6
PLt1	Plant fault 1
PLt2	Plant fault 2
PLt3	Plant fault 3
PLt4	Plant fault 4
PLt5	Plant fault 5
PLt6	Plant fault 6

Network Alarms

The table below shows the text and associated type number that is sent to the system "front end". The type number is normally used to provide different alarm actions.

Alarm text	Type # (index)
Probe 1 faulty	6
Probe 2 faulty	8
Probe 3 faulty	11
Probe 4 faulty	14
Probe 5 faulty	17
Probe 6 faulty	6
Channel 1 over temperature	4
Channel 2 over temperature	9
Channel 3 over temperature	12
Channel 4 over temperature	15
Channel 5 over temperature	18
Channel 6 over temperature	4
Channel 1 under temperature	5
Channel 2 under temperature	10
Channel 3 under temperature	13

Alarm text	Type # (index)
Channel 4 under temperature	16
Channel 5 under temperature	19
Channel 6 under temperature	5
Plant 1 fault	6
Plant 2 fault	8
Plant 3 fault	11
Plant 4 fault	14
Plant 5 fault	17
Plant 6 fault	6
Channel 1 defrost over-run	20
Channel 2 defrost over-run	20
Channel 3 defrost over-run	20
Channel 4 defrost over-run	20
Channel 5 defrost over-run	20
Channel 6 defrost over-run	20

Probe Offset

This feature allows each probe value to be modified by an "offset". Offset values are from -10°C (-18°F) to +10°C (+18°F) and on a channel basis. Example C1 = Probe 1.

Note : - Please note that when using the Split function on the DMTouch, not all parameters may be available (i.e. probe offsets)



Ensure that all power is switched off before installing or maintaining this product

	Mercury Mk2 Monitor PR0710-MON	Intuitive Mercury Monitor PR0750-MON
Power requirements		
Supply Voltage Range	100 - 240 Vac \pm 10%	100 - 240 Vac \pm 10%
Supply Frequency	50 - 60 Hz	50 - 60 Hz
Maximum supply current	5.2 Amps (when relay 5 is fully loaded)	2 Amps
Typical supply current	<1 Amp	<1 Amp
General		
Operating temperature range	+5 ^o C to +50 ^o C	-10 ^o C to +60 ^o C
Storage temperature range	-20 ^o C to +65 ^o C	-20 ^o C to +65 ^o C
Environmental	Indoor use at altitudes up to 2000m, pollution degree 1, installation category II. Voltage fluctuations not to exceed \pm 10% of nominal voltage.	Indoor use at altitudes up to 2000m, pollution degree 1, installation category II. Voltage fluctuations not to exceed \pm 10% of nominal voltage.
Size	78mm (W) x 36mm (H) x 110mm (D)	157mm (W) x 67mm (H) x 120 (D)
Approx Weight	170 grams	500 grams
Safety	EN61010	EN61010
EMC	EN61326; 1997 +Amdt. A1; 1998	EN61326; 1997 +Amdt. A1; 1998
Ventilation	There is no requirement for forced cooling ventilation	There is no requirement for forced cooling ventilation
Class 2 Insulation	No protective Earth is required and none should be fitted	No protective Earth is required and none should be fitted
Supply Fuse	The host equipment must provide a suitable external over-current protection device such as: - Fuse: 6.3A 240 Vac Antisurge (T) HRC conforming to IEC 60127	Built in fuse holder, fuse 2A 240Vac Antisurge (T) HRC conforming to IEC60127, 32 x 6.3mm
Or MCB	6A, 240 VAC Type C conforming to BS EN 60898	2A, 240 VAC Type C conforming to BS EN 60898 (Note: controller has integral 2A fuse)
Relay Fuse	Not Fitted	10A 240Vac Antisurge (T) HRC conforming to IEC60127, 32 x 6.3mm
Relay Specification		
	Relays 1-4 Exclusive common	Relays 1-5 Exclusive common
Max current	6A Resistive (Cos ϕ = 1) 2A Inductive (Cos ϕ = 0.4)	.10A Resistive (Cos ϕ = 1) 3A Inductive (Cos ϕ = 0.4)
Max voltage	250Vac, 30V dc	250Vac, 30V dc
Relay Fuse	N/A	10A 240Vac Antisurge (T) HRC conforming to IEC60127, 32 x 6.3mm
		All relays are independent and can operate at different potentials to the supply voltage.
	Relay 5 Common connected to supply live	
Max current	3A (non inductive), COS ϕ =0.4 2A (inductive load) 200,000 operations	
Max voltage	250Vac (Internal supply)	
	For compliance with the LVD, relays 3, 4 and 5 commons must be at the same potential as the supply voltage	

Specification



Warning: On Mercury Mk2 Controller Relay 5 output has hazardous voltages (Supply input voltage potential) This does not apply to the Intuitive Mercury controller



Ensure that all power is switched off before installing or maintaining this product

Inputs

Input resistance: 3.01K Ohms (for PTC or NTC type probes)
 Input type: See: [Units](#) (selectable)
 Comms: RS232 with flow control

Switched Resistor Example Wiring

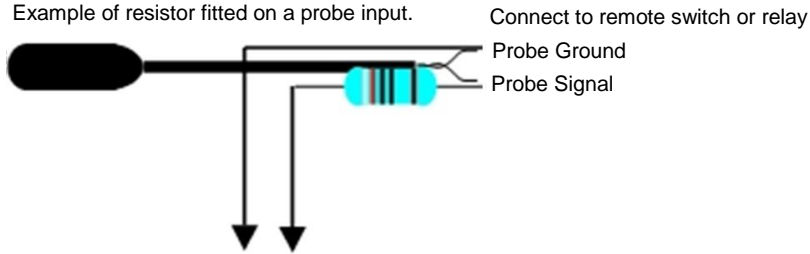

Installation

Panel Cut-out and Clearances

Mercury Mk2 (Flush mount controller)

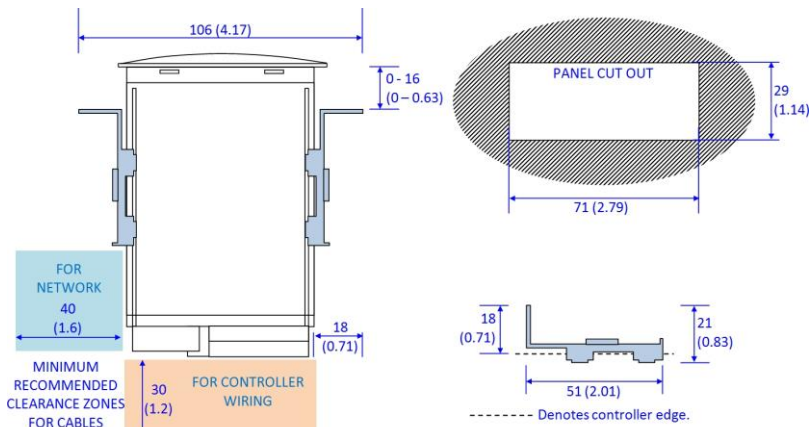

Fixing

The controller is fixed by sliding the 2 plastic retaining clips up to rear of the panel. These clips have a ratchet action and can be removed by holding in the clip sides and sliding back.

There is no requirement for forced cooling ventilation

Dimensions

Mercury Mk2

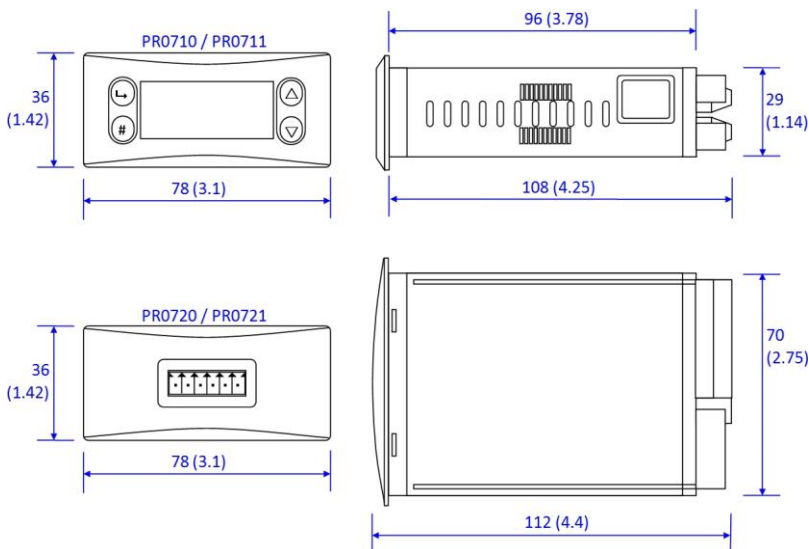

Ensure that all power is switched off before installing or maintaining this product

Dimensions

Intuitive Mercury controller

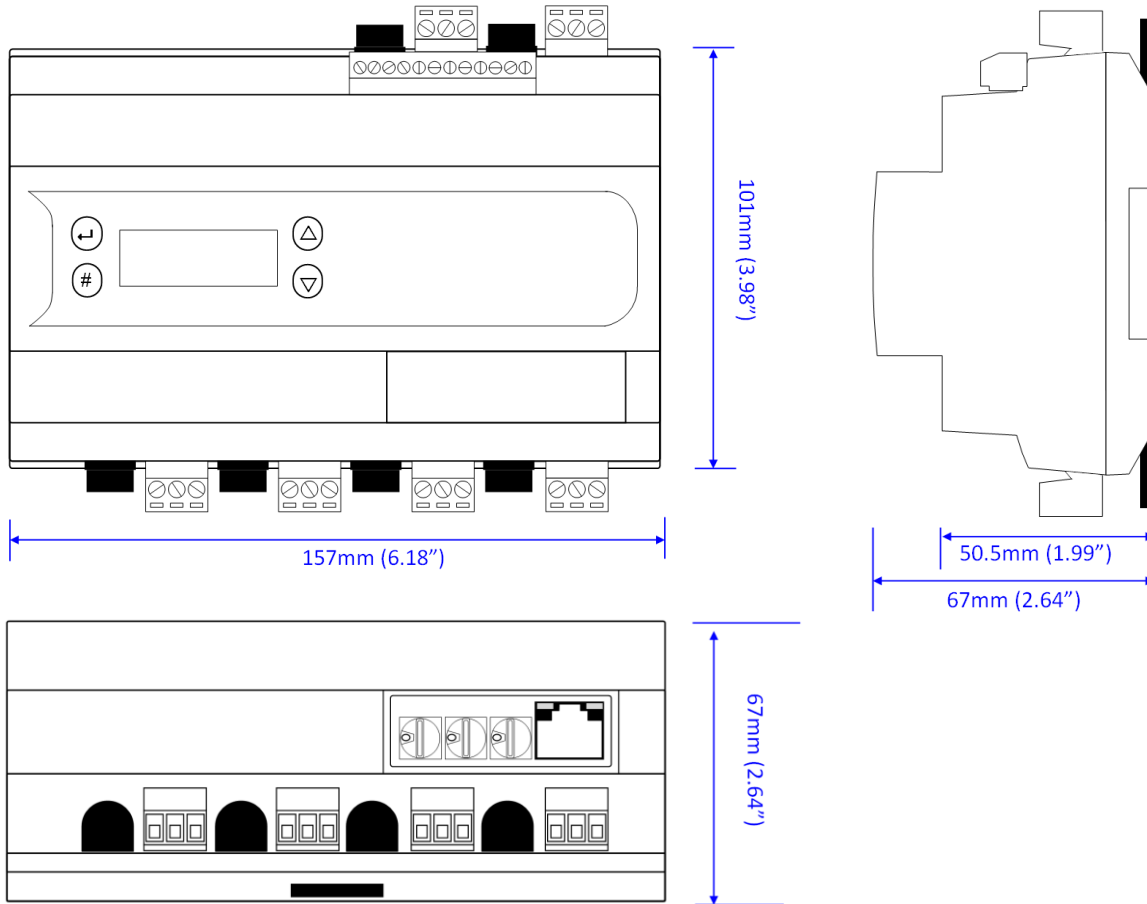

Intuitive Mercury Mounting Instructions

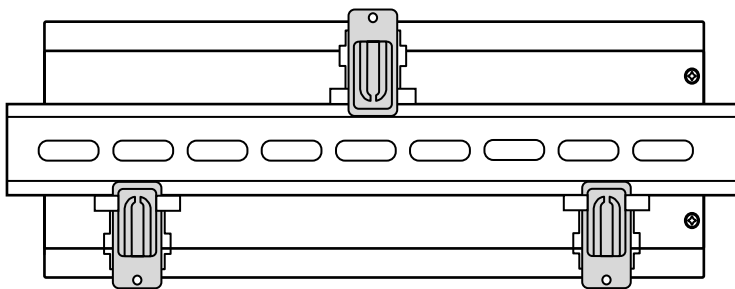

Three clips fix the Intuitive Mercury securely to DIN rail. Pull each clip until it “clicks” to remove the controller. Each clip has a mounting hole to provide an alternative fixing mechanism to DIN mounting.

Cleaning

Do not wet the controller when cleaning. Clean the front by wiping with slightly dampened lint free cloth.

Disclaimer

The specifications of the product detailed in this document may change without notice. RDM Ltd shall not be liable for errors or omissions, for incidental or consequential damages, directly or indirectly, in connection with the furnishing, performance or misuse of this product or document.



Ensure that all power is switched off before installing or maintaining this product

Revision History

Revision	Date	Changes
1.8	30/05/2011	Current Issue
1.8a	06/01/2015	Operating temperature range updated
1.8b	13/06/2018	Note added relating to split function on DMTouch



Ensure that all power is switched off before installing or maintaining this product