



**Mercury**  
PR0710-MOB  
PR0720-MOB



**Intuitive**  
PR0750-MOB  
PR0760-MOB

# Mercury 2 & Intuitive Mercury Mobile Controller Installation & User Guide

## Resource Data Management

### UK OFFICE

Resource Data Management Ltd  
80 Johnstone Avenue,  
Hillington Industrial Estate,  
Glasgow, Scotland, G52 4NZ, UK  
☎ +44(0)141 810 2828  
✉ sales@resourcedm.com

### US OFFICE

Resource Data Management Inc  
100 North Sixth Street,  
Suite 630B,  
Minneapolis, MN 55403, USA  
☎ Tel +1 612 354 2923  
✉ usasales@resourcedm.com



**Table of Contents:**

..... 1

**THE MERCURY & INTUITIVE RANGE** ..... 4

    Variants ..... 4

    Compatible Displays ..... 4

**Configuration** ..... 4

**Compatible Network Interfaces** ..... 4

**Front Display Features** ..... 5

**Connections** ..... 5

**Mercury Mk2 6-5E and 6-5M** ..... 5

**Intuitive Mercury Controller** ..... 6

    Ordering Information ..... 6

**Input and Output Allocation Tables** ..... 7

    Input / Output allocation table ..... 7

    Switched Resistor Values ..... 7

**Setting up the controller** ..... 7

    Setup through front buttons ..... 7

    Setup Function Menu ..... 8

**Recommended set-up method** ..... 8

    rtc. Real time clock (This will automatically synchronise on network systems) ..... 8

    type. Set/view controller type ..... 8

    PArA. Set/view parameters (This can be achieved at the network front end) ..... 8

    Unit. Set/view temperature unit and Probe type ..... 8

    Display ..... 9

**Parameter Tables** ..... 9

**Parameter Descriptions** ..... 10

**Relay State and functional operation** ..... 12

**Relay and screen states during defrost** ..... 13

    Defrost Type (P-91) ..... 13

    Defrost Termination ..... 13

    Fan Delay after Defrost ..... 13

**Network Configuration** ..... 13

    RS485 Legacy module / Intuitive Internal RS485 Network card ..... 13

    Wireless Mesh Communication Module ..... 14

    Fast Network Address Reset ..... 14

    IP Futura module / Intuitive Internal IP Network card ..... 14

**Mercury Switch** ..... 15

**Viewing** ..... 15

    Input / Output Table ..... 15

    Maximum and Minimum Control Temperature ..... 16

**Messages** ..... 16

**Network Alarms** ..... 16

**Modifying controller states** ..... 16

    Fans Only “FAnS” ..... 17

    Case Off “CASE” ..... 17

    Lights Only “Ligt” ..... 17

    Probe Offset ..... 17

**Remote Commands** ..... 17

    Power requirements ..... 18

    General ..... 18

    Relay Specification ..... 18

**Specification** ..... 18

    Inputs ..... 19

**Switched Resistor Example Wiring** ..... 19

**Installation** ..... 19



Ensure that all power is switched off before installing or maintaining this product

Fixing..... 19

**Dimensions ..... 19**

**Dimensions ..... 20**

    Intuitive Mercury Mounting Instructions ..... 20

    Cleaning ..... 20

**Disclaimer..... 20**

**Revision History ..... 21**

## The Mercury & Intuitive Range From Resource Data Management

For Version Mob 1.0

The Mercury Mk2 Mobile controller is intended for use in refrigeration display cabinets with one or two integral compressors with each compressor having a temperature probe fitted to enable the compressor to be stopped if a set (discharge) temperature is exceeded. The controller will switch on one or two compressors based on the average of an air on and air off temperature probes and has outputs to control lights, fans and defrost control. The lighting relay can be set to operate as an alarm relay if required. The controller also has an inbuilt defrost timer and 7 day lighting control timer which can also be used to switch the cabinet off and on at specific times, this can be a useful energy saving feature if the cabinet contains non perishable goods (such as drinks) and can be automatically switched off at night.

There is also a DIN rail mounted version, known as the Intuitive Mercury, which is designed to be used in a control panel or electrical tray. This range has the same features as the Mercury Mk2 controller with additional benefits such as higher rated relays, each protected by an integral fuse and fuse protection for the incoming power supply. All connections are plug in socket and there are multiple network interfaces to choose from including Ethernet.

The controller supports PT1000, NTC2K, 470R, 700R, 3K, 5K, 6K, NTC2K25, NTC10K or NTC10K(2) temperature probes (note: probe types cannot be mixed)

### Variants

Description	Part Number
Mercury Mk2 Single or Twin Compressor Controller, integral display.	PR0710-MOB
Mercury Mk2 Single or Twin Compressor Controller, remote display.	PR0720-MOB
Intuitive Mercury Single or Twin Compressor Controller, integral display.	PR0750-MOB
Intuitive Mercury Single or Twin Compressor Controller, remote display.	PR0760-MOB
Intuitive Mercury Single or Twin Compressor Controller, integral display, built in IP network card.	PR0750-MOB-IP
Intuitive Mercury Single or Twin Compressor Controller, remote display, built in IP network card.	PR0760-MOB-IP

### Compatible Displays

The following displays are compatible with the Mercury / Intuitive Remote Display Controllers (PR0720 & PR0760): -

Description	Part Number
Mercury Remote Display with 5m cable	PR0325
Mercury Keypad Remote Display with 5m cable	PR0326
Mercury DIN Remote Display with 5m cable	PR0327
Mercury DIN Keypad Remote Display with 5m cable	PR0328
Mercury mk2 Remote Display with 5m cable	PR0725

### Configuration

The controller gives you two configuration options: -

Display value	Type
1	Integral controller HT
2	Integral controller LT

The controller is delivered pre-configured as type 1.

### Compatible Network Interfaces

Mercury and Intuitive Mercury controllers are capable of connecting to either a TCP/IP local area network, an RS485 Genus compatible network, an RDM wireless mesh network or they can be used in standalone mode with no network output. To connect to a network you must add the correct communications module. Connecting to any of these communication modules will automatically be detected on power up and will affect the set up screens available to you.

Description	Part Number
IP Futura (Single Mercury to IP Interface)	PR0016
RS485 Interface (Single Mercury to RS485 Interface)	PR0026
Mercury IP Switch (IP support for 10 controllers)	PR0018
Mercury IP Switch with Pressure/Humidity Inputs	PR0018-PHI
Wireless Mesh Interface (for single Mercury)	PR0730

The Intuitive Mercury Controller is supplied as standard with an internal RS232 network card, this allows connection to any of the above external network interfaces. Three alternative internal network cards are also available, these can be supplied factory fitted as an option or purchased separately as an interface kit.



Ensure that all power is switched off before installing or maintaining this product

Description	Part Number
Intuitive Internal IP Network Card Interface Kit	PR0770
Intuitive Internal RS485 Network Card Interface Kit	PR0771
Intuitive Internal Wireless Mesh Network Card Interface Kit	PR0772

## Front Display Features

LED's: -

Cooling (Relay 1 or 4)

Fans (Relay 2)

Lights (Relay 3)

Defrost (Relay 5)

On-Line

Off No network attached  
Flashing Attempting to Log on to network  
Steady On-line

Service (See Parameter 18 for setup)

Alarm

HACCP



## Keys

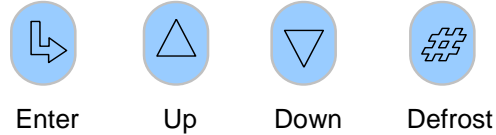

Note: Function keys illuminate when pressed, illumination is turned off 20 seconds after the key is used. Press and hold the defrost button to force a manual defrost

## Main Display



4 character LED display, used to display temperature and status messages.

**Note** the Intuitive Mercury display is Green in colour when lit.

## Connections

### Mercury Mk2 6-5E and 6-5M

Input and Output connections are made to the back of the controller, the RS232 communication port is on the side. The diagram shows the connection detail.

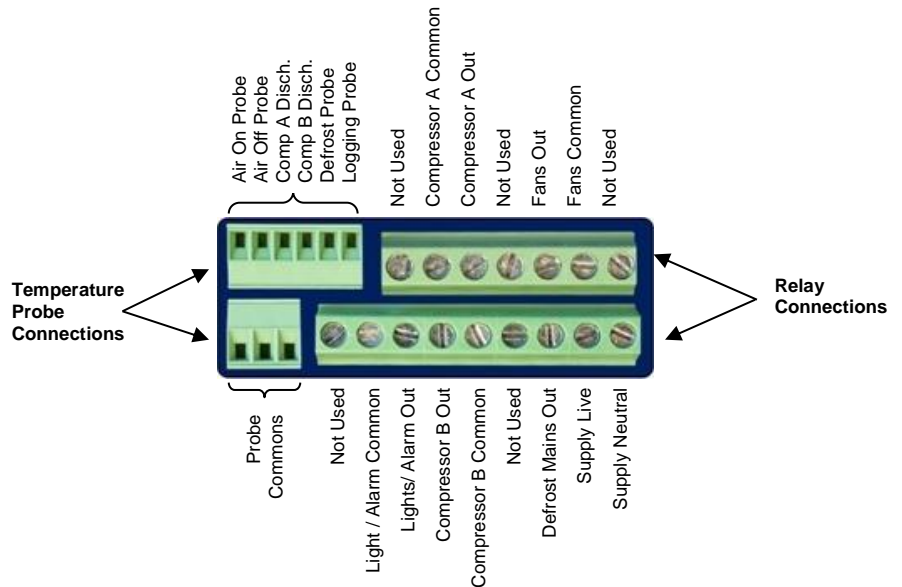

Ensure that all power is switched off before installing or maintaining this product

## Intuitive Mercury Controller

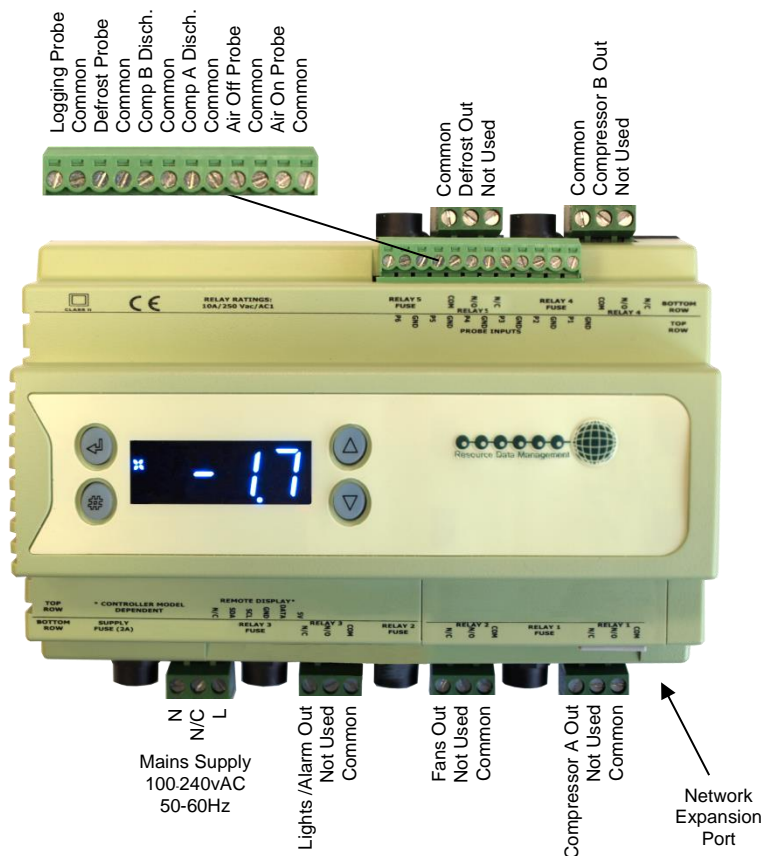

All inputs and outputs are plug and socket. The supply voltage and relay outputs have individual fuse protection.

## Intuitive Mercury Network Expansion Options

### RS232 Network Card (Default)



The Intuitive Mercury is supplied with an RS232 Network Card fitted as standard. Some example optional network cards are shown below

### IP Network Card (PR0770)



Rotary Address Switches, Network Collision LED, Network Activity LED

### RS485 Network Card (PR0771)



Ground, B-, A+, Screen, Network Activity LED

PR0772 Wireless Mesh Option also available. The network interfaces work in the same way as there external counterparts.

## Ordering Information

When ordering a Mercury Intuitive controller the following ordering scheme can be used to purchase the desired hardware configuration. This ensures the controller ships with the optional hardware pre-fitted.

**PR07X0-Y** Where **X** and **Y** and are selections from the tables below.

X	Description
5	Internal Display
6	Remote Display

Y	Description
	RS232*
IP	IP Interface
RS485	RS485 Interface

\* Fitted by default.

Example – To order a remote display variant, with a built in IP module use the following part number: -

PR0760-IP



Ensure that all power is switched off before installing or maintaining this product

**Input and Output Allocation Tables**

The following tables indicate; on a controller type basis, the functions of the inputs and outputs. Also shown are the digital inputs that are derived by switching in a fixed value resistor across the input.

**Input / Output allocation table**

TYPE	Integral Case Types 1&2	Alarm Action	Plant Input (Switched Resistors)
Input 1	Air on Temperature	Yes	
Input 2	Air off Temperature	Yes	
Input 3	Compressor A Discharge Temperature	Yes	Plant fault 1 or External Defrost Input **
Input 4	Compressor B Discharge Temperature	Yes	Case Clean Switch
Input 5	Defrost Termination or Monitor probe (if used)	Conditional*	Plant fault 2
Input 6	Logging Probe (If fitted)	Conditional*	
Relay 1	Compressor A	N/A	
Relay 2	Fans	N/A	
Relay 3	Lights/Alarm Relay	N/A	
Relay 4	Compressor B	N/A	
Relay 5	Defrost Heater	N/A	

\* Alarm on monitor probe only if used

\*\* Defrost type must be set to remote in parameters.

**Switched Resistor Values**

For PT1000 probes use 820 Ohm switched resistors. For NTC2K, NTC2K25 and 3K probes use 590 Ohm switched resistors. For 5K and 6K use 1K Ohm switched resistors. For NTC10K probes use 2k7 Ohm switched resistors. For NTC10K(2) probes use 2k2 Ohm switched resistors. The resistors used must have a tolerance of 1% or better and the resistor must have a power rating of 0.25W. For improved accuracy whilst using switched resistors RDM recommend resistors with 0.1% accuracy are used. Note the switched resistor features will **not** function when using 470R or 700R probes. When a resistor is switched across the appropriate input it signals to the Mercury to enable the switched resistor function described for that input whilst still recording the probe temperature on the input.

Temperature range for all probe types is -49°C to +127°C for probe inputs which do not have a secondary function (switched resistors). Inputs which have a secondary function are restricted to -42°C to +60°C. If the full temperature range is required on all inputs and no switch resistor features are needed then please see Switch Resistor parameter P-19

Note: switched resistors will operate in LT (Low Temperature) and HT (High Temperature) applications using PT1000, NTC2K or NTC2K25 probe types only. For all other probe types the switched resistor inputs will work in HT applications only.

**Setting up the controller**

Access to the controller can be achieved several ways

- Through the front mounted buttons
- Direct access by PC into the side comms port. This requires the Communicator software package available free on the RDM website
- Through legacy front end panels on 485 networks
- Through the RDM Data Manager.
- Across an IP network. (Current controller IP address required)

**Setup through front buttons**



To enter setup mode, hold the Enter and Down buttons together for approximately 3 seconds until the message "Ent" appears on the display. Now press the Enter button again to enter the function menu. IO will be displayed. Scroll up or down to go through the list.

**Setup Function Menu**

Display	Option	Explained in Paragraph	Display	Option	Explained in Paragraph
IO	View Inputs / Outputs and States	<a href="#">Input / output table</a>	nEt	Set/view network configuration	<a href="#">Network Configuration</a>
PArA	Set/View Parameters	<a href="#">Set view parameters</a>	SoFt	View software version	
Unit	Probe type and Celsius/Fahrenheit option	<a href="#">Set View Unit</a>	FANs	Toggle Fans Only mode	<a href="#">Fans</a>
diSP	Display whole units or decimal	<a href="#">Display</a>	CASE	Toggle Case Off mode	<a href="#">Case Off</a>
tyPE	Set/View Controller Type	<a href="#">Set/view controller type</a>	Ligt	Toggle Lights Only mode	<a href="#">Lights</a>
rtc	Set/view Clock (rtc = Real Time Clock)	<a href="#">Real Time Clock</a>	OFSt	Probe Offset	<a href="#">Probe Offset</a>
			ESC	Exit Setup mode	

**Recommended set-up method**

If you are not connecting to a network and want to set up the controller through the buttons we recommend you use the following order from the function menu.

**rtc. Real time clock (This will automatically synchronise on network systems)**

- Use the up or down buttons to scroll through the display until the display reads “rtc”
- Press enter. The display will show “t-1”. press enter again
- Scroll hours up or down (0 – 23) press enter
- Use up button to select “t-2”, press enter
- Scroll minutes up or down (0 – 59) press enter
- Repeat for t-3 (seconds 0 – 59)
- Repeat for t -4 (Days up to 31)
- Repeat for t -5 (months up to 12)
- Repeat for t -6 (Year up to 99)
- Use up button to display “ESC”, press enter to display “rtc”

Time clock is now set

**type. Set/view controller type**

- From the function menu scroll to select type, press enter
- Use the up/down buttons to scroll through HT/LT configuration types. (see [configuration table on](#) page 4)
- Press enter.
- Scroll to select “ESC”
- Press enter

Controller type configuration is now set

**PArA. Set/view parameters (This can be achieved at the network front end)**

- From the function menu scroll to select PArA
- Pressing Enter while PArA is displayed will enter the parameter menu. The first parameter option will be displayed as P-01. Pressing the Up or Down button will present the other parameter options P-02, P-03 etc. See the parameter list below to find what parameter number corresponds to which actual parameter. Pressing the Enter button will show the current value of the selected parameter. Press Up or Down to modify the value and press Enter again to save the value. The parameter list number will be displayed again. Two other options are present in the parameter menu – dFLt and ESC. Selecting ESC will exit setup mode. Selecting dFLt will reset all parameters back to the default values for the current type of controller.

**Unit. Set/view temperature unit and Probe type**

From the function menu scroll to select Unit  
Press enter and the value will be displayed: -

**Probe Types**

- |                         |  |
|-------------------------|--|
| 0 for PT1000 Celsius    | 10 for NTC2K25 Celsius                   |
| 1 for PT1000 Fahrenheit | 11 for NTC2K25 Fahrenheit                |
| 2 for NTC2K Celsius     | 12 for 5K Celsius                        |
| 3 for NTC2K Fahrenheit  | 13 for 5K Fahrenheit                     |
| 4 for 470R Celsius      | 14 for 6K Celsius                        |
| 5 for 470R Fahrenheit   | 15 for 6K Fahrenheit                     |
| 6 for 700R Celsius      | 16 for NTC10K Celsius                    |
| 7 for 700R Fahrenheit   | 17 for NTC10K Fahrenheit                 |
| 8 for 3K Celsius        | 18 for NTC10K(2) Celsius (USA NTC10K)    |
| 9 for 3K Fahrenheit     | 19 for NTC10K(2) Fahrenheit (USA NTC10K) |

Use the up or down keys to select the units and press enter.

**This function is now complete**



Ensure that all power is switched off before installing or maintaining this product

**Display**

From the function menu scroll to and select diSP.  
 Press enter and one of the following values will be shown: -  
 0. Controller display will show the whole number and tenths value of a temperature reading. (Default)  
 1. Controller display will show temperatures as a whole number.

**Parameter Tables**

Number	Parameter	Range °C ( °F )	Step	Units	Default LT °C (°F)	Default HT °C (°F)
P-01	Cut-in Temp.	-42 to 30 (-43.6 to 86)	0.1	Deg	-20 (-4)	3.5 (38.3)
P-02	Cut In Differential	0 to 10 (0 to 18)	0.1	Deg	2.5 (4.5)	2.5 (4.5)
P-03	Control Weight	0 to 100	1	%	40	30
P-04	Display Weight	0 to 100	1	%	40	30
P-05	Lag Comp Delay	00:00 to 15:00	00:05	mm:ss	00:40	00:10
P-06	Anti SC Time	00:00 to 15:00	00:05	mm:ss	07:00	07:00
P-07	Lag Cut Out Diff	0 to 10 (0 to 18)	0.1	Deg	2.5 (4.5)	2.5 (4.5)
P-85	Key-switch Mode	0 = Case Off 1 = Fans only 2 = toggle	1		0	0
P-87	Control Probe type	0 = Use Air on Probe 1 = Use Log Probe	1		0	0
P-90	Resistor Case Off	0 (Disabled),1(Enabled)			0	0
P-92	Fans temperature mode	0 = Off 1 = Temperature 2 = Over-temperature 3 = Temp/OT	1		0	0
P-93	Fans Off Temperature	-42 to 30 (-43.6 to 86)	0.1	Deg	-10 (14)	8 (46.4)
P-15	Probe 5 Select	0 = Defrost, 1 = Monitor	1		0	0
P-16	Relay 3 Mode	0 = Lights, 1 = Alarm	1		0	0
P-29	Probe 3 Resistor function	0 = Plant fault, 1 = External defrost	1		0	0
P-18	Service Interval time	0 to 128	1	KHrs	60	60
P-19	Switch Resistors	0 (Off), 1(On)			1	1
P-98	Lights Case Off	0 (Off), 1 (On), 2 (Unused)			0	0
P-99	Load Shedding	0 (Off), 1 (Mode 1), 2 (Mode 2)	1		0	0
P-30	Do (enable) Discharge Stop Compressor A	0 (Off), 1(On)	1		0	0
P-31	Do (enable) Discharge Stop Compressor B	0 (Off), 1(On)	1		0	0
P-32	Discharge Stop Value	-49 to 128	0.1	Deg	55	55
P-33	Discharge Stop Differential	-42 to 30	0.1	Deg	10	10
P-34	Maximum Compressor Run Time	00:00 to 99:00	01:00	mm:ss	00:00	00:00
P-35	Comp Stop Both	0 = Yes 1 = No	1		0	0
P-20	Alarm Delay	00:00 to 99:00	01:00	mm:ss	20:00	20:00
P-21	UT Alarm	-49 to 60 (-56.2 to 140)	0.1	Deg	-30 (-22)	-2 (28.4)
P-22	OT Alarm	-49 to 60 (-56.2 to 140)	0.1	Deg	-15 (5)	5 (41)
P-23	Log Probe Type	0 (Off), 1 (Logging), 2 (Logging/Alarm)			Off	Off
P-24	Slug Log Probe	0 (Off), 1 (On)			Off	Off
P-25	Log Alarm Delay	00:00 to 99:00	01:00	mm:ss	20:00	20:00
P-26	Log UT Alarm	-49 to 60 (-56.2 to 140)	0.1	Deg	-35 (-31)	-1 (30.2)
P-27	Log OT Alarm	-49 to 60 (-56.2 to 140)	0.1	Deg	-12 (10.4)	6 (42.8)
P-28	Monitor OT Alarm	-49 to 60 (-56.2 to 140)	0.1	Deg	20 (68)	20 (68)
P-40	Defrost Mode	0 (Local), 1 (Remote), 2 (External)			Local	Local
P-41	Defrost Start	00:00 to 23:59	00:01	hh:mm	01:00	01:00
P-42	Defrosts per Day	0 to 8	1		6	6
P-43	No Defrost Time	0 to 25	1	hours	12	12
P-44	Def Terminate Temp.	-42 to 30 (-43.6 to 86)	0.1	Deg	14 (57.2)	10 (50)
P-45	Def Min Time	00:00 to 99:00	01:00	mm:ss	05:00	05:00



Ensure that all power is switched off before installing or maintaining this product

P-46	Def Max Time	00:00 to 99:00	01:00	mm:ss	30:00	30:00
P-47	Drain Down	00:00 to 24:00	00:15	mm:ss	01:30	00:30
P-48	Recovery Time	00:00 to 99:00	01:00	mm:ss	30:00	30:00
P-89	Pump Down Time	00:00 to 99:00	01:00	mm:ss	00:00	00:00
P-86	Fan Delay mode	0 = Time 1 = Temp	1		0	0
P-49	Fan Delay Time	00:00 to 99:00	01:00	mm:ss	00:00	00:00
P-88	Fan Delay Temp	-42 to 30 (-43.6 to 86)	0.1	Deg	-20 (-4)	0.0 (32)
P-50	Fans In Defrost	0 (Off), 1 (On)			On	On
P-91	Defrost Type (Integral)	0 = Elec. 1 = Gas. 2 = Elec CIn			0	0
P-94	Defrost Hold	0 (Off), 1 (On)			Off	Off
P-95	Defrost Skip	0 (Off), 1 (On)			Off	Off
P-96	Defrost Skip Time	00:00 to 99:00	01:00	mm:ss	12:00	12:00
P-60	Lights Mode	0 (Local), 1 (Remote), 2 (Man Off), 3(Man On)			Local	Local
P-61	Sun Lights On	00:00 to 23:59	00:01	hh:mm	08:00	08:00
P-62	Sun Lights Off	00:00 to 23:59	00:01	hh:mm	20:00	20:00
P-63	Mon Lights On	00:00 to 23:59	00:01	hh:mm	08:00	08:00
P-64	Mon Lights Off	00:00 to 23:59	00:01	hh:mm	20:00	20:00
P-65	Tue Lights On	00:00 to 23:59	00:01	hh:mm	08:00	08:00
P-66	Tue Lights Off	00:00 to 23:59	00:01	hh:mm	20:00	20:00
P-67	Wed Lights On	00:00 to 23:59	00:01	hh:mm	08:00	08:00
P-68	Wed Lights Off	00:00 to 23:59	00:01	hh:mm	20:00	20:00
P-69	Thu Lights On	00:00 to 23:59	00:01	hh:mm	08:00	08:00
P-70	Thu Lights Off	00:00 to 23:59	00:01	hh:mm	20:00	20:00
P-71	Fri Lights On	00:00 to 23:59	00:01	hh:mm	08:00	08:00
P-72	Fri Lights Off	00:00 to 23:59	00:01	hh:mm	20:00	20:00
P-73	Sat Lights On	00:00 to 23:59	00:01	hh:mm	08:00	08:00
P-74	Sat Lights Off	00:00 to 23:59	00:01	hh:mm	20:00	20:00
dFLt	Restore defaults					

Parameter Descriptions

Number	Parameter	Description
P-01	Cut-in Temp	Temperature at which the lead compressor will switch on.
P-02	Diff	Differential temperature below the cut-in temperature. The lead compressor switches off when below this temperature
P-03	Control Weight	Percentage of the Air-On temperature that is used to calculate the control temp. The remaining percentage will be used on the Air-Off temperature Example, P-03 set to 30% Control temp = 30% Air-on + 70% Air-off
P-04	Display Weight	As above only applied to the display temperature
P-05	Lag Comp Delay	Delay before the second compressor is switched on if the temperature is still above set-point. <b>Note</b> – The lead and lag compressors swap after each defrost to even the run times.
P-06	Anti SC Time	Allows the user to set the compressor for a given number of starts/hour
P-07	Lag Cut Out Diff	Diff below the Cut-In Temp the lag compressor switches off. <b>Single Compressor Operation</b> To disable compressor B operation and use only a single compressor for control set parameter P-07 to 0. This will allow the controller work with just one compressor (A) and ignore compressor B.
P-85	Key-switch Mode	Allows the keys switch to be: - ➤ Single turn for case off (Case off mode) ➤ Single turn for Fans only (Fans Mode) ➤ Single turn for case off, double turn for fans only (Toggle mode)
P-87	Control Probe type	Switches between using the air-on probe and the Logging probe. Note the control and display temperature will still be a derivative of the weighted Average of the control probe + Air-off probe
P-90	Resistor Case Off	Turns on/off the switched resistor case off function
P-92	Fans temperature mode	Allows the user to set the fans to turn off when: - ➤ A pre-determined temperature is reached (P93) ➤ When an over-temperature alarm is present ➤ When either P93 is reached or an OT alarm is present
P-93	Fans Off Temperature	Temperature for the above (P92) operation. <b>Note</b> the defrost termination probe is the source of the temperature reading used in this feature. If the defrost termination probe isn't fitted then a similar process to P-44 is used.
P-15	Probe 5 Select	This input can be used as a defrost termination probe (default) or as a monitor probe with an OT alarm



Ensure that all power is switched off before installing or maintaining this product

		level (P-28)
P-16	Relay 3 mode	This changes the function of relay 3 from Lights (default) to an alarm relay. The alarm relay is energised for no alarm. Use the NC and Common for "Loop make" on alarm or use the NO and Common for "Loop break" on alarm.
P-29	Probe 1 or Probe 3 Resistor	Selects whether the switched resistor invokes either a Plant fault or an External Defrost.
P-18	Service Interval Time (Run Hours)	Time (in 1000 x hours) before the service icon (Spanner icon) comes on. The Run Hours timer increments based on the number of hours the controller has been powered up and running. Reset the spanner icon to off by changing this parameter to 0 and then back to the desired service interval. This process also resets the Run Hours value to 0. To view the current Run Time value refer to the I/O list.
P-19	Switch Resistors	Enables switched resistors to be used for Plant Faults, External Defrosts, Case Clean. See : <a href="#">Switched Resistor Values</a>
P-98	Lights Case Off	Used to place the controller into Case Off when its lighting timer is in the off state. When the lighting timer is in the on state the controller follows its normal control operation. This feature is disabled if the set point (P-01) is below 6°C. Please note that when the controller is in case off all alarms are inhibited and all outputs are turned off. Therefore care must be taken when enabling this parameter. <ul style="list-style-type: none"> <li>➢ Off – Feature is not used and only the controller lights relay follows the lighting timer status.</li> <li>➢ On - Feature is in use and controller will be in Case Off whenever the lights timer is in the off state.</li> <li>➢ Unused – This selection has no effect and should not be used. Please select from either Off or On. This feature operates in either Local, using controller RTC, or Remote, using Data Manager GP timer channel, lighting applications.</li> </ul>
P-99	Load Shedding	<ul style="list-style-type: none"> <li>➢ Off – Feature is not used</li> <li>➢ Mode 1 – Case goes to "CO2 Load Shedding Case Off Mode"</li> <li>➢ Mode 2 – Goes to Case Clean Mode</li> </ul> See: <a href="#">Load Shedding</a>
P-30	Do Discharge Stop Compressor A	This enables the discharge stop on compressor A, if set to ON then the compressor will be disabled if the discharge temperature is exceeded.
P-31	Do Discharge Stop Compressor B	This enables the discharge stop on compressor B, if set to ON then the compressor will be disabled if the discharge temperature is exceeded.
P-32	Discharge Stop Value	If a compressor discharge probe exceeds this value and P-30 and P-31 are set to ON then the relevant compressor will be disabled.
P-33	Discharge Stop Differential	This is the differential below the discharge stop value that the discharge probe temperature has to drop before the compressor is enabled again.
P-34	Maximum Compressor Run Time	This limits the running time of any compressor, once the compressor has exceeded this time period it will be switched off for the period of the anti short cycle time (P-06)
P-35	Comp Stop Both	If either compressor stops due to expiry of the Maximum Compressor Run Time then both compressors will be disabled if P-35 is set to On.
P-20	Alarm Delay	Delay for the over and under-temperature alarms
P-21	UT Alarm	Under temperature alarm set point. This alarm uses the control temperature.
P-22	OT Alarm	Over temperature alarm set point. This alarm uses the air-off temperature.
P-23	Log Probe Type	Allows the user to set the logging probe mode: - <ul style="list-style-type: none"> <li>➢ Off</li> <li>➢ Logging with no alarms</li> <li>➢ Logging with alarms</li> </ul>
P-24	Slug Log Probe	Applies a damping factor. This can be used to make a standard probe have the same temperature response as a logging probe.
P-25	Log Alarm Delay	Delay for the Logging probe over and under-temperature alarms
P-26	Log UT Alarm	Logging probe under temperature alarm set point
P-27	Log OT Alarm	Logging probe over temperature alarm set point
P-28	Monitor OT Alarm	Monitor probe over temperature alarm set point
P-40	Defrost Mode	Allows the user to set the defrost mode: - <ul style="list-style-type: none"> <li>➢ Local (Uses the internal parameters P-41 and P-42)</li> <li>➢ Remote (Requires a defrost schedule in the front end)</li> <li>➢ External (uses a switched resistor in input 3 ). When this signal is present a defrost is initiated.</li> </ul> Note: - If the external defrost signal is not removed then the controller will defrost according to the "No Defrost" time and a missed defrost alarm will be generated. See P-29 for external defrost signal setup.
P-41	Defrost Start	When defrost mode is set to "Local", this is the start time for the 1 <sup>st</sup> defrost
P-42	Defrosts per Day	When defrost mode is set to "Local", this is the number of defrosts per day equally spaced from the start time.
P-43	No Defrost Time	If the controller misses a defrost command for any reason, a defrost will initiate after this time has elapsed from the last defrost. Normally set to 2 hours over the normal defrost interval period.
P-44	Def Terminate	The defrost will terminate (defrost control relay off) when the temperature of the defrost termination probe reaches this value, if a defrost probe is not fitted then the air off program will be used.
P-45	Def Min Time	Minimum time that a defrost will use (Defrost can't terminate until this time has elapsed. If termination temperature is reached during this period, the defrost control relay is turned off but the controller will not start refrigerating until the end of the defrost min period)

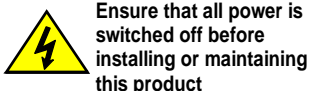

P-46	Def Max Time	Maximum time period allowed for defrosting if termination temperature is not reached.
P-47	Drain Down	A period after defrost max to allow the draining of any surplus water
P-48	Recovery Time	The compressor(s) is switched on at the start of this period to allow the temperature to recover to the normal operating point. This period also inhibits the OT alarm. Note that if the air-off temperature is still above the OT alarm setpoint when this period expires, an immediate OT alarm occurs; there is <b>not</b> a further alarm delay.
P-89	Pump Down Time	Time period before the defrost min period to allow for a pump down
P-86	Fan Delay mode	This parameter allows the fans start after a drain-down period to be delayed, either by time (P-49) or when the temperature point (P-88) is reached. This parameter uses the same probe strategy as the defrost terminate.
P-49	Fan Delay	Time after a drain-down period before the fans start if P-86 is set to time
P-88	Fan Delay Temp	Temperature at which the fans start after a drain-down period when P-86 is set to temperature.
P-50	Fans In Defrost	Allows the user to set the fans on or off in defrost. Note if the fans are set to on in defrost, they will go off for the drain-down period and then follow the P-86 rules.
P-91	Defrost Type	Electric – Defrost heater will go off during defrost min. period, if defrost termination is achieved, and will stay off. Electric Cln – Defrost heater will go off during defrost min. period if defrost termination is achieved but will then cycle on and off around the termination temperature setpoint until the end of the defrost min. period. Gas - If gas is selected, the compressor is kept running for the duration of the defrost cycle.
P-94	Defrost Hold	Turns the defrost hold feature on and off. When switched on, the controller can be held in defrost until a remote command from the front end starts the recovery process.
P-95	Defrost Skip	Allows user to enable/disable defrost skip. This feature allows the controller to skip defrosts. If the current defrost terminates on temperature then the controller will skip the next scheduled defrost providing the previous defrost terminated before the defrost skip time (P-96). Operates only when the controller is set to local defrost scheduling.
P-96	Defrost Skip Time	Time factor used in defrost skip. The previous defrost has to terminate before this value expires to allow the controller to skip a defrost.
P-60	Lights Mode	Allows the user to set the lights mode: - <ul style="list-style-type: none"> <li>➤ Always off</li> <li>➤ Always on</li> <li>➤ Use a local schedule P-61 to P-74)</li> <li>➤ Use a remote schedule (Set up in the system front end)</li> </ul>
P-61	Sun Lights On	When P-60 is set to Local, Sunday on time
P-62	Sun Lights Off	When P-60 is set to Local, Sunday off time
P-63	Mon Lights On	When P-60 is set to Local, Monday on time
P-64	Mon Lights Off	When P-60 is set to Local, Monday off time
P-65	Tue Lights On	When P-60 is set to Local, Tuesday on time
P-66	Tue Lights Off	When P-60 is set to Local, Tuesday off time
P-67	Wed Lights On	When P-60 is set to Local, Wednesday on time
P-68	Wed Lights Off	When P-60 is set to Local, Wednesday off time
P-69	Thu Lights On	When P-60 is set to Local, Thursday on time
P-70	Thu Lights Off	When P-60 is set to Local, Thursday off time
P-71	Fri Lights On	When P-60 is set to Local, Friday on time
P-72	Fri Lights Off	When P-60 is set to Local, Friday off time
P-73	Sat Lights On	When P-60 is set to Local, Saturday on time
P-74	Sat Lights Off	When P-60 is set to Local, Saturday off time
dFLt	Restore default values	Restores all of the parameters to their default values <b>USE WITH CAUTION</b>

Relay State and functional operation

Relay 1-3 State	Function State	Wired contact
Relay 1 off	Compressor A on	N/C
Relay 1 on	Compressor A off	N/C
Relay 2 off	Fans on	N/C
Relay 2 on	Fans off	N/C
Relay 3 off	Lights on	N/C
Relay 3 on	Lights off	N/C

Relay 4-5 State	Function State	Wired contact
Relay 3 off	Alarm Relay = Alarm	N/C
Relay 3 on	Alarm Relay = OK	N/C
Relay 4 off	Compressor B off	N/O
Relay 4 on	Compressor B on	N/O
Relay 5 off	Defrost control off	N/O
Relay 5 on	Defrost control on	N/O



Ensure that all power is switched off before installing or maintaining this product

Relay and screen states during defrost

State:	Pump Down	Defrost Min	Defrost Max	Drain Down	Fan Delay	Recovery
Screen:	DEF	DEF	DEF	DEF	DEF	REC
Def LED:	On	On	On	Off	Off	Off
RLY 1 Comp A (Defrost set to gas)	Off	On	On	Off	On	On
RLY 1 Comp A (Defrost set to electric)	Off	Off	Off	Off	On	On
RLY 1 Comp A (Defrost set to elec/cln)	Off	Off	Off	Off	On	On
RLY 4 Comp B	Off	Off	Off	Off	On if Reqd	On if reqd
RLY 5 Defrost Relay	Off	Off/Cycles*	On	Off	Off	Off
RLY 3 Lights relay (Timer channel On)	On	On	On	On	On	On
RLY 2 Fans (On in DF)	On	On	On	On	Off	On
RLY 2 Fans (Off in DF)	Off	Off	Off	Off	Off	On

\*The defrost relay will cycle around the termination setpoint during defrost min if defrost type is set to elec/cln, otherwise it will be off.

Defrost Type (P-91)

If P-91 is set to gas, compressor A is switched on for the duration of the defrost cycle.

Defrost Termination

Defrost termination will be when the temperature parameter "def terminate" has been reached on the "defrost termination" probe. If the "defrost termination" probe is not fitted then the air off probe will be used.

Fan Delay after Defrost

The fans will come back on when: -

The fan delay time has elapsed if the "fan delay mode" is set to time

Or If the fan delay mode is set to "temp", the fans will come on when the defrost termination probe reaches the fan delay set point, or on the time parameter, whichever occurs first.

If the "defrost termination" probe is not fitted, the fans will come on when the air off probe reaches the control set point (If fans are selected as "on during defrost")

Network Configuration

The final section to setup is the network address. In all instances, this must be done before the controller is plugged into the site network. The controllers have an auto-initialise function, which will automatically log the device onto the site network. If the wrong address has been entered onto the network, you will have to reset the controller address by setting the address to 00-0, and then re-enter the correct address. (You may have to deregister the wrong address from the home system as well).

When logging a Mercury or Intuitive Mercury with an RS232 interface onto a network you must first connect the controller to a communications module, this is either a 485 Legacy, RDM Wireless Mesh system, IP Futura or Mercury Switch. When using an Intuitive Mercury controller, the controller has to have the correct network card fitted (see "compatible network interfaces"). For connection to a Mercury Switch (Hub) or an external network interface, the standard fitment RS232 network card is utilized.

RS485 Legacy module / Intuitive Internal RS485 Network card

Connecting an RS485 legacy Module or an Intuitive Internal RS485 network card to the controller will govern which set up screens are made available. Both modules support the "Genus" protocol only.

Display	Option
485t	485 Network Type
485A	485 Address/Name
gAdd	Show underlying network address assigned to controller
rLog	Re-log the controller back onto the network
CLrA	Clear the address/name from the controller
ESC	Exit network menu. <b>N.B.</b> this option <b>must</b> be selected to save any changes made in this menu

The 485t option shows a value representing the network type. The possible values are:

Value	Network Type
1	Genus compatible (all versions)
2	RDM Wireless Mesh System (Wireless Mesh)

The 485A option shows a value representing either the name of the controller in a Genus compatible or Wireless Mesh network.



Ensure that all power is switched off before installing or maintaining this product

**Wireless Mesh Communication Module**

RDM Wireless Mesh System, please refer to the RDM Wireless Mesh Communication Module user guide, which can be obtained from the RDM website, for information regarding connecting a controller to a Wireless Mesh network. The value shown in 485A is of the form 05-6. This means the controller would try to log onto a Genus compatible or RDM Wireless Mesh network using the name 'RC05-6'.

The gAdd option displays (in hexadecimal format) the underlying network address assigned to the controller when it was logged onto the network.

The rLog option allows the controller to be logged back onto the network with its current name. The 'rLog' message will flash for confirmation. Press the Enter button to execute the command, Up or Down buttons to cancel.

**Fast Network Address Reset**

The CLrA option will clear out the network address and name in the controller. The 'ClrA' message will flash for confirmation. Press the Enter button to execute the command, Up or Down buttons to cancel.

To enter this mode, hold the Enter, Up and Down buttons together for approximately 3 seconds until the message CLrA appears on the display. CLrA is the first option in the menu consisting of the following options:

Display	Option
CLrA	Clear the address/name from the controller
ESC	Exit Setup mode

Pressing the Enter button to select the CLrA option will cause the 'CLrA' message to flash for confirmation, if the network type is set to Genus compatible. Press the Enter button to execute the command, Up or Down buttons to cancel. If the network type is not set to Genus compatible then the CLrA message will not flash and the ESC option can be used to exit the menu.

**IP Futura module / Intuitive Internal IP Network card**

In an IP system there are two options,

- IP-L
- IP-r

IP-L allows you to fix an IP address into the controller, which you would use when you are connecting the controllers onto a customer's local area network. This would allow the customer to view each controller using Internet Explorer

IP-r allows you to give each controller on the system a unique number. This number is then allocated a dynamic IP address by the system DHCP server (such as the RDM Data Manager)

**IP-L**

To configure the communication module or network card for IP-L, set all three rotary switches to zero. The module should then be connected to the controller. In the case of an Intuitive Mercury controller where the network card is already fitted, the controller should be powered off, all three rotary switches set to zero and the controller powered on.

1. nEt. From the function menu you can now select nEt
  - Press enter and the display will show "IP-L", press enter
  - You can now set the address using the table below

Display	Option
IP-1	IP Address byte 1
IP-2	IP Address byte 2
IP-3	IP Address byte 3
IP-4	IP Address byte 4
nL	Network Mask Length
gt-1	Gateway Address byte 1
gt-2	Gateway Address byte 2
gt-3	Gateway Address byte 3
gt-4	Gateway Address byte 4
ESC	Exit network menu. <b>N.B.</b> this option <b>must</b> be selected to save any changes made in this menu



Ensure that all power is switched off before installing or maintaining this product

## IP-r

To configure the communication module for IP-r, set the three rotary switches to give each controller a unique identifier. The module should then be connected to the controller and the network. In the case of an Intuitive Mercury controller where the network card is already fitted, the three rotary switches must be set when the controller is powered off, the controller should then be powered on to connect to the network.

2. nEt. From the function menu you can now select nEt
  - Press enter and the display will show "IP-r", press enter
  - You can now view only the address given by the DHCP server

To ease setup, a single network mask length value is used. If the address has been specified with a network mask value in dotted IP format e.g. 255.255.255.0 then the table below gives the conversion:

Mask	Length	Mask	Length	Mask	Length
255.255.255.252	30	255.255.254.0	23	255.254.0.0	15
255.255.255.248	29	255.255.252.0	22	255.252.0.0	14
255.255.255.240	28	255.255.248.0	21	255.248.0.0	13
255.255.255.224	27	255.255.240.0	20	255.240.0.0	12
255.255.255.192	26	255.255.224.0	19	255.224.0.0	11
255.255.255.128	25	255.255.192.0	18	255.192.0.0	10
255.255.255.0	24	255.255.128.0	17	255.128.0.0	09
		255.255.0.0	16	255.0.0.0	08

## Mercury Switch

Please refer to the Mercury Switch user guide, which can be obtained from the RDM website, for information regarding connecting a controller to a network.

## Viewing

Apart from setting up the controller, you can also view the status of the inputs and outputs and controller states. From the function menu, select "I/O", press enter. You can now scroll through the IO table as set out below. Inputs and outputs that do not apply to a particular controller type will be greyed out.

## Input / Output Table

Number	IO	Range* °C ( °F )	Step	Units
I-01	Control Temp.	-42 to 60 (-43.6 to 140)	0.1	Deg
I-02	Display temp	-42 to 60 (-43.6 to 140)	0.1	Deg
I-03	Air on Probe	-49 to 60 (-56.2 to 140)	0.1	Deg
I-04	Air off Probe	-49 to 60 (-56.2 to 140)	0.1	Deg
I-05	Comp A Discharge Probe	-42 to 60 (-43.6 to 140)	0.1	Deg
I-06	Comp B Discharge Probe	-42 to 60 (-43.6 to 140)	0.1	Deg
I-08	Logging Probe	-49 to 60 (-56.2 to 140)	0.1	Deg
I-09	Defrost Probe	-49 to 60 (-56.2 to 140)	0.1	Deg
I-10	Plant Fault 1	0 (OK), 1 (Alarm)		
I-11	Case Clean	0 (Off), 1 (On)		
I-14	Plant Fault 2	0 (OK), 1 (Alarm)		
I-15	Monitor Probe	-49 to 60 (-56.2 to 140)	0.1	Deg
I-18	External Defrost	0 (Off), 1 (On)		
I-20	Load Shedding	0 (Off), 1 (On)		
O-03	Compressor A	0 (Off), 1 (On)		
O-04	Compressor B	0 (Off), 1 (On)		
O-05	Defrost Control	0 (Off), 1 (On)		
O-06	Lights	0 (Off), 1 (On)		
O-07	Case Fans	0 (Off), 1 (On)		
O-10	Last Def. Time	00:00 to 23:59		hh:mm
O-11	Last Def. Length	00:00 to 03:00		hh:mm



Ensure that all power is switched off before installing or maintaining this product

O-12	Last Def. Ctrl Temp.	-42 to 60 (-43.6 to 140)	0.1	Deg
O-13	Last Def. Type	0 (None), 1 (Internal), 2 (External), 3 (Network), 4 (Display), 5 (Timed) 6 (Forced), 7 (Skipped)		
O-16	Alarm Relay	0 (Unused), 1 (OK), 2 (Alarm)		
O-18	Run Time	0 – 128 K Hours	1	
O-30	Set Point Offset	-49 to 60 (-56.2 to 140)	0.1	Deg.
S-01	Control State	0 (Stabilise), 1 (Normal), 2 (Defrost Min), 3 (Defrost Max), 4 (Drain Down), 5 (Fan Delay), 6 (Recovery), 7 (OT Alarm), 8 (UT Alarm), 9 (Fans Only), 10 (Lights Only), 11 (Case Off), 12 (Pump Down), 13 (Defrost Hold), 14 (Load Shed)		

\* Range is dependent on probe type

**Maximum and Minimum Control Temperature**

Type M only (Not supported in type E).

To view the maximum or minimum Control Temperature the controller has reached since last power off/on press and hold the Up and Down Buttons together for 3 seconds. The display will show "diSP", press the Up Button to view the maximum Control Temperature the controller has reached or press the Down Button to view the minimum Control Temperature the controller has reached. Display will revert back to normal operation if the Enter Button is pressed or after 1 minute of no button presses. The top bar of the left hand segment will be lit when the maximum temperature is being displayed. The bottom bar of the left hand segment will be lit when the minimum temperature is being displayed. Resetting the controller will clear out these values.

**Messages**

The following alarms and messages can appear on the Mercury display.

Display Message	System status
Ft	Control Fault
Prb1	Probe 1 Fault
Prb2	Probe 2 Fault
Prb3	Probe 3 Fault
Prb4	Probe 4 Fault
Prb5	Probe 5 Fault
Prb6	Probe 6 Fault
rEC	Control State in Recovery
dEF	Control Sate in Defrost

Display Message	System status
FAnS ONLY	Controller in Fans Only
LitS ONLY	Controller in Lights Only
CASE OFF	Controller in Case Off
Ot	Over Temperature Alarm
Ut	Under Temperature Alarm
PLnt	Plant Fault
LgOt	Log Probe Over Temperature
LgUt	Log Probe Under Temperature
AL	Control State in Alarm

**Network Alarms**

The table below shows the text and associated type number that is sent to the system "front end". The type number is normally used to provide different alarm actions.

Alarm text	Type # (index)
Missed defrost	15
Plant Fault 1	3
Case over temperature	4
Case under temperature	5
Probe 1,2,3,4,5 or 6 Faulty	6
Product over temperature	8
Product under temperature	9

Alarm text	Type # (index)
Plant Fault 2	3
Monitor Probe OT	12
Case Off	29
Load Shedding	7
Compressor A stop	3
Compressor B stop	3

**Modifying controller states**

During normal operation you can change the following states from the function menu



Ensure that all power is switched off before installing or maintaining this product

**Fans Only “FAnS”**

Selecting the Fans Only option will put the controller into the Fans Only state if the current state is not Fans Only. If the current state is Fans Only then the controller will change to the Normal state. Selecting this option will exit the setup menu automatically. The display will show “FAnS OnLy”

If a remote display with key switch is being used, this function can be invoked by turning the key switch to the fans only position (90 degrees clockwise) with parameter P85 set to "fans"

**Case Off “CASE”**

Selecting the Case Off option will put the controller into the Case Off state if the current state is not Case Off. If the current state is Case Off then the controller will change to the Normal state. Selecting this option will exit the setup menu automatically. The display will show “CASE OFF”. An alarm is generated, fixed delay of 1 minute, when the controller is placed into the Case Off state.

If a remote display with key switch is being used, this function can be invoked by turning the key switch to the case-off position. (Clockwise 90 degrees) with parameter P85 set to "case".

**Lights Only “Ligt”**

Selecting the Lights Only option will put the controller into the Lights Only state if the current state is not Lights Only. If the current state is Lights Only then the controller will change to the Normal state. Selecting this option will exit the setup menu automatically. The display will show “LitS OnLy”

Note. When lights are being used in “Remote” mode with a timing channel: -

If the controller goes offline, the lights are turned ON after a delay of 5 minutes. The lights will stay on until the controller comes back on-line where they will revert to the state of the timing channel being used.

**Probe Offset**

This feature allows each probe value to be modified by an “offset”. Offset values are from -10°C (-18°F) to +10°C (+18°F) and on a channel basis. Example C1 = Probe 1.

**Remote Commands**

The following commands can be used by a Data Builder program: -

Command	Value to send	Description	Conditions
Defrost Command	1	Initiates a defrost cycle	Defrost mode: remote
Defrost Command	3	Terminates the defrost	Defrost mode: remote Defrost hold: On Defrost min state complete
Setpoint Command	+/-18	Is added to or subtracted from the setpoint	
Case Off Command	5	Sets the controller to Case Off	
	0	Restores the controller from Case Off to Normal	
Haccp Command	0	HACCP LED OFF	
	1	HACCP LED On	
	2	HACCP LED Flashes	
Button Command	0	Buttons backlights Off	
	1	Buttons backlights On	
	2	Buttons Backlights Flash	

Use an “Analogue Out” block configured to the controller name and in the value field type in the command you require. Use a “Setting block” as the input to the “Analogue Out” block to send the Value.

See Example on the right, which increases the setpoint by 10 degrees.

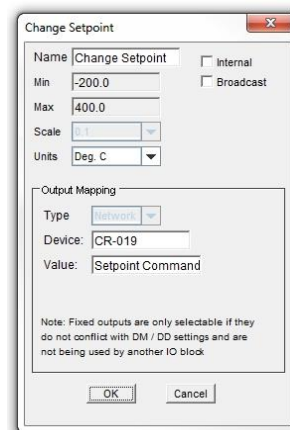
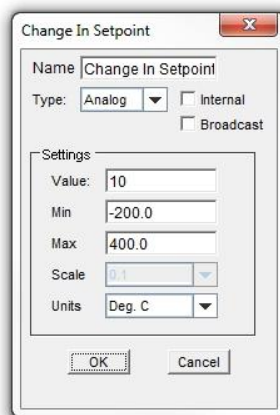

Ensure that all power is switched off before installing or maintaining this product

## Specification

	Mercury Mk2 Controller PR0710-MOB & PR0720-MOB	Intuitive Mercury controller PR0750-MOB & PR0760-MOB
<b>Power requirements</b>		
<b>Supply Voltage Range</b>	100 - 240 Vac $\pm$ 10%	100 - 240 Vac $\pm$ 10%
<b>Supply Frequency</b>	50 - 60 Hz	50 - 60 Hz
<b>Maximum supply current</b>	5.2 Amps (when relay 5 is fully loaded)	2 Amps
<b>Typical supply current</b>	<1 Amp	<1 Amp
<b>General</b>		
<b>Operating temperature range</b>	+5°C to +50°C	-10°C to +60°C
<b>Storage temperature range</b>	-20°C to +65°C	-20°C to +65°C
<b>Environmental</b>	Indoor use at altitudes up to 2000m, pollution degree 1, installation category II. Voltage fluctuations not to exceed $\pm$ 10% of nominal voltage.	Indoor use at altitudes up to 2000m, pollution degree 1, installation category II. Voltage fluctuations not to exceed $\pm$ 10% of nominal voltage.
<b>Size</b>	78mm (W) x 36mm (H) x 110mm (D)	157mm (W) x 67mm (H) x 120 (D)
<b>Approx Weight</b>	170 grams	500 grams
<b>Safety</b>	EN61010	EN61010
<b>EMC</b>	EN61326; 1997 +Amdt. A1; 1998	EN61326; 1997 +Amdt. A1; 1998
<b>Ventilation</b>	There is no requirement for forced cooling ventilation	There is no requirement for forced cooling ventilation
<b>Class 2 Insulation</b>	<b>No</b> protective Earth is required and <b>none</b> should be fitted	<b>No</b> protective Earth is required and <b>none</b> should be fitted
<b>Supply Fuse</b>	The host equipment must provide a suitable external over-current protection device such as: - Fuse: 6.3A 240 Vac Antisurge (T) HRC conforming to IEC 60127	Built in fuse holder, fuse 2A 240Vac Antisurge (T) HRC conforming to IEC60127, 32 x 6.3mm
<b>Or MCB</b>	6A, 240 VAC Type C conforming to BS EN 60898	2A, 240 VAC Type C conforming to BS EN 60898 (Note: controller has integral 2A fuse)
<b>Relay Fuse</b>	Not Fitted	10A 240Vac Antisurge (T) HRC conforming to IEC60127, 32 x 6.3mm
<b>Relay Specification</b>		
<b>Relays 1-4 Mechanical Type (M) Exclusive common</b>		
<b>Max current</b>	6A Resistive (Cos $\phi$ = 1) 2A Inductive ( Cos $\phi$ = 0.4)	10A Resistive (Cos $\phi$ = 1) 3A Inductive ( Cos $\phi$ = 0.4)
<b>Max voltage</b>	250Vac, 30V dc	250Vac. 30V dc
<b>Relay Fuse</b>	N/A	10A 240Vac Antisurge (T) HRC conforming to IEC60127, 32 x 6.3mm
<b>Relay 5 Mechanical Type (M) Common connected to supply live</b>		<b>Relay 5 Mechanical Type (M) Exclusive common</b>
<b>Max current</b>	3A (non inductive), COS $\phi$ =0.4 2A (inductive load) 200,000 operations	10A Resistive (Cos $\phi$ = 1) 3A Inductive ( Cos $\phi$ = 0.4)
<b>Max voltage</b>	250Vac (Internal supply)	250Vac. 30V dc (external supply)
	For compliance with the LVD, relays 3, 4 and 5 commons must be at the same potential as the supply voltage	All relays are independent and can operate at different potentials to the supply voltage.

**Warning: Relay 5 output has hazardous voltages (Supply input voltage potential)  
This does not apply to the Intuitive Mercury controller**



Ensure that all power is switched off before installing or maintaining this product

## Inputs

Input resistance: 3.01K Ohms (for PTC or NTC type probes)  
 Input type: Selectable. See: [Units](#)

Comms: RS232 with flow control

## Switched Resistor Example Wiring

Example of resistor fitted on a probe input. Connect to remote switch or relay

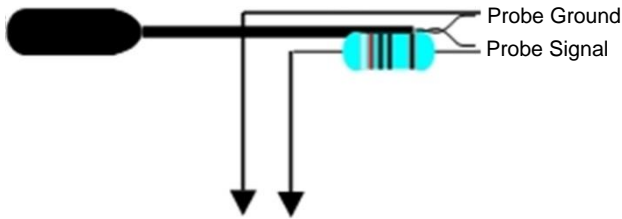

## Installation

### Panel Cut-out and Clearances

#### Mercury Mk2 (Flush mount controller)

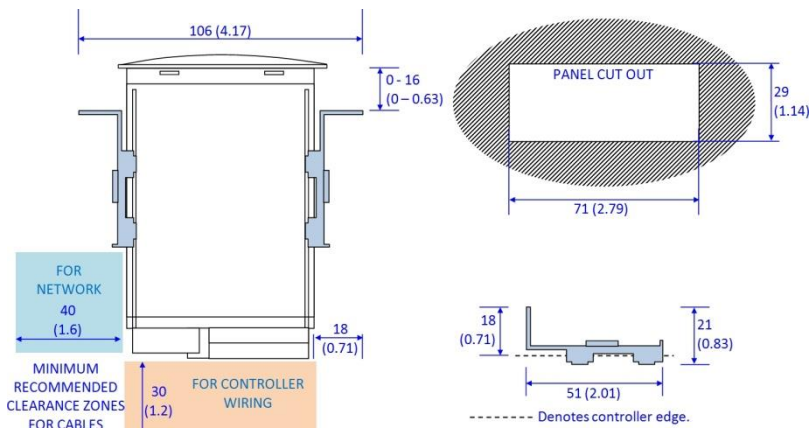

## Fixing

The controller is fixed by sliding the 2 plastic retaining clips up to rear of the panel. These clips have a ratchet action and can be removed by holding in the clip sides and sliding back.

There is no requirement for forced cooling ventilation

## Dimensions

### Mercury Mk2

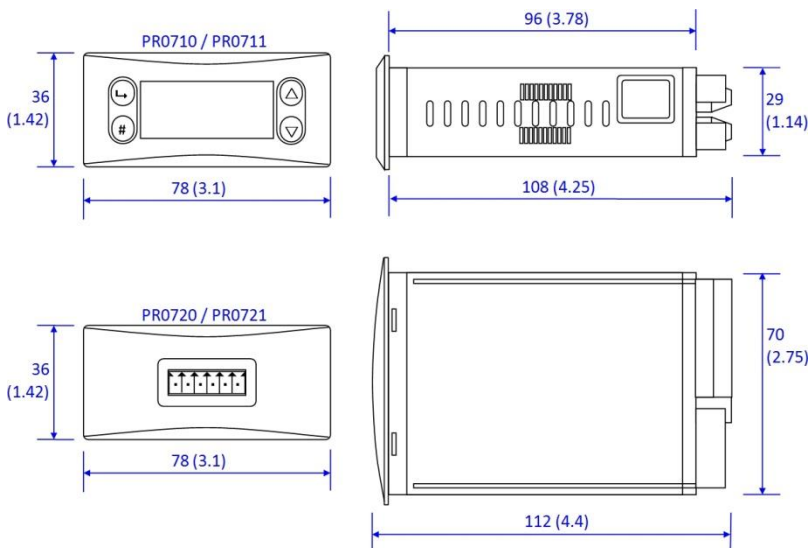

Ensure that all power is switched off before installing or maintaining this product

**Dimensions**

**Intuitive Mercury controller**

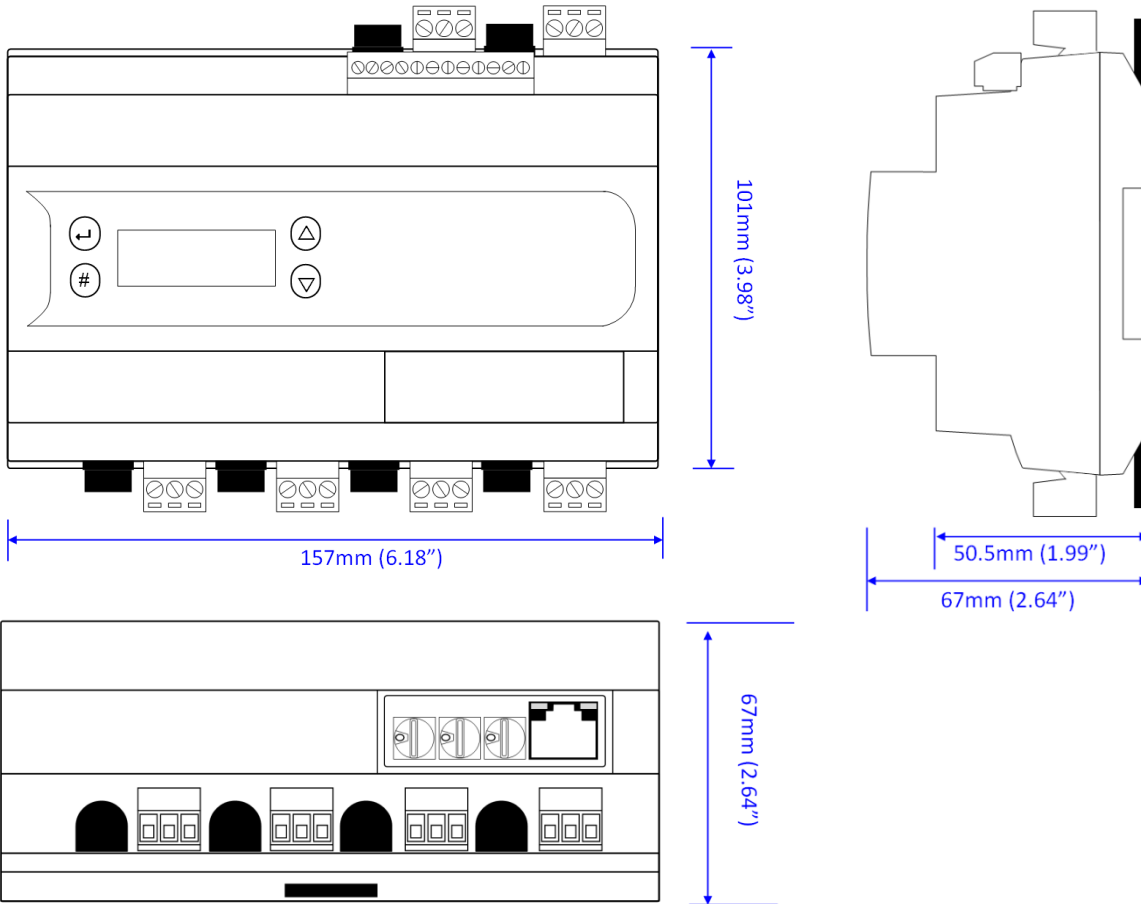

**Intuitive Mercury Mounting Instructions**

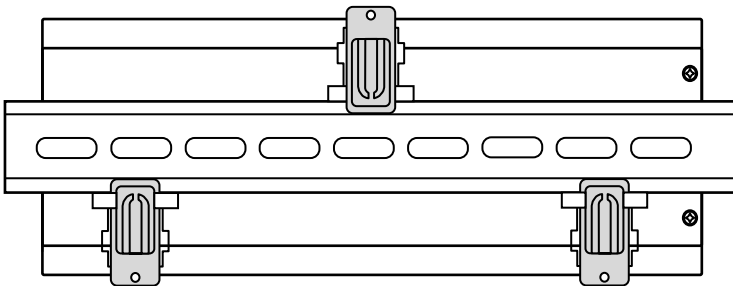

Three clips fix the Intuitive Mercury securely to DIN rail. Pull each clip until it “clicks” to remove the controller. Each clip has a mounting hole to provide an alternative fixing mechanism to DIN mounting.

**Cleaning**

Do not wet the controller when cleaning. Clean the front by wiping with slightly dampened lint free cloth.

**Disclaimer**

The specifications of the product detailed in this document may change without notice. RDM Ltd shall not be liable for errors or omissions, for incidental or consequential damages, directly or indirectly, in connection with the furnishing, performance or misuse of this product or document.

## Revision History

Revision	Date	Changes
1.0	23/01/2014	First Issue
1.1	29/01/2014	Maximum Compressor Run Time description added.
1.2	17/02/2014	P-35 "Comp Stop Both" parameter added.
1.2a	05/01/2015	Operating Temperature range updated.



Ensure that all power is switched off before installing or maintaining this product