

Resource  
Data Management

# Mercury 3 Control Thermostat

Commissioning/User Guide  
Revision 3.0c



PR0740-STA

## Contents

The Mercury 3 Range .....	4
Description: .....	4
Variants .....	4
Compatible Displays .....	4
Configuration .....	4
Compatible Network Interfaces .....	4
Front Display Features .....	5
Connections .....	5
Mercury Mk3 .....	5
Input / Output allocation table .....	6
Ordering Information .....	6
Setting up the controller.....	7
Setup through front buttons.....	7
Setup Function Menu (Common to all types) .....	7
Recommended set-up method.....	8
rtc. Real time clock (This will automatically synchronise on network systems) .....	8
type. Set/view controller type .....	8
Unit. Set/view temperature unit and Probe type .....	8
Display .....	8
PARA. Set/view parameters (This can be achieved at the network front end) .....	9
Parameter Table for Control Thermostat .....	9
Parameter Descriptions .....	11
Network Configuration – RS232 comms.....	13
RS485 Legacy module .....	13
Wireless Mesh Module .....	14
IP Futura module.....	14
Mercury Switch.....	15
Network Configuration – IP comms .....	15
Viewing .....	16
Input / Output Table .....	16
Display Messages .....	17
Network Alarms .....	17
Normal Operation .....	17
Faults.....	17



Please ensure all power is switched off before installing or maintaining this product.

Network .....	17
Probe Offset.....	17
Set Point .....	17
Valve Symbol.....	17
Operation .....	18
Relay Actions .....	19
Alarm Relay Action .....	19
GP Timer Set-up.....	19
Remote Commands .....	20
Specification .....	21
Installation .....	22
Fixing.....	22
Dimensions.....	22
Cleaning .....	22
Disclaimer .....	23
Revision History .....	23



Please ensure all power is switched off before installing or maintaining this product.

# The Mercury 3 Range

## From Resource Data Management

### Description:

The Mercury Control Stat is a multi-purpose thermostat controller that can be used in heating/cooling applications. Control can be achieved from either input 1 or 2 or by a percentage weighting of the two inputs. The remaining inputs can be configured as override, fault or run input's. The Stat allows for two heating and two cooling differential's to be set with an optional time or temperature delay on the second stage of heating/cooling. Included in the controller is a frost detect parameter. This over-rides the timer function, when the timer is off, to begin heating should the temperature reach the frost detect value. There is a 7-day timer with two on/off times per day. Over/Under temperature alarms can be configured with an optional delay. The ability to enable any relay as an alarm relay is included as well as the option to map a relay to the status of the controller timer. The user can predefine the number fans operating at any one time or if more than one fan is configured their operation can be controlled by fuzzy logic.

The controller supports PT1000, NTC2K, 470R, 700R, 3K, 5K, 6K, NTC2K25, NTC10K or NTC10K(2) USA temperature probes (note: probe types cannot be mixed)

### Variants

Description	Display	Comms
Mercury Mk3 Control Thermostat	Integral/ Remote Display	Serial/ Ethernet

### Compatible Displays

The following displays are compatible with the Mercury Remote Display Controllers:-

Description	Part Number
Mercury Remote Display with 5m cable	PR0325
Mercury Keyswitch Remote Display with 5m cable	PR0326
Mercury DIN Remote Display with 5m cable	PR0327
Mercury DIN Keyswitch Remote Display with 5m cable	PR0328
Mercury mk2 Remote Display with 5m cable	PR0725

### Configuration

There is only one type of configuration in the Mercury Control Thermostat.

### Compatible Network Interfaces

Mercury controllers are capable of connecting to either a TCP/IP local area network, an RS485 Genus compatible network or they can be used in standalone mode with no network output. To connect to a network you must add the correct communications module. Connecting to any of these communication modules will automatically be detected on power up and will affect the set up screens available to you.

Description	Part Number
IP Futura (Single Mercury to IP Interface)	PR0016
RS485 Interface (Single Mercury to RS485 Interface)	PR0026
Mercury IP Switch (IP support for 10 controllers)	PR0018
Mercury IP Switch with Pressure/Humidity Inputs	PR0018-PHI



Please ensure all power is switched off before installing or maintaining this product.

## Front Display Features

### LED's:

**Valve** (Indicates Controller Operational State)



**Fans** (Selectable Relay)



**Lights** (Not Used)



**Defrost** (Not Used)



**On-Line**



Off No network attached  
 Flashing Attempting to Log on to network  
 Steady On-line

**Service** (Indicates additional Parameter setting mode)



**Alarm** (Selectable Relay)



**HACCP**



### Keys



Enter



Up



Down



Defrost

Note: Function keys illuminate when pressed, illumination is turned off 20 seconds after the key is used. Press and hold the defrost button to force a manual defrost.

### Main Display



4 character LED display, used to display temperature and status messages.

## Connections

### Mercury Mk3

Input and Output connections are made to the back of the controller, the RS232 communication port is on the side. The diagram shows the connection detail. Inputs and outputs are assigned according to the chosen configuration. See [Input/Output](#) tables for further details on connections.

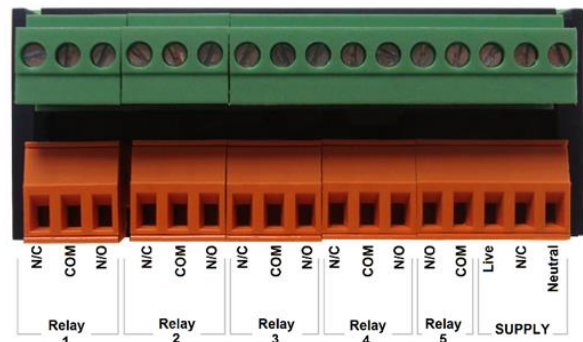

Please ensure all power is switched off before installing or maintaining this product.

## Input / Output allocation table

TYPE	Description	Alarm Action	Comments
Probe 1	Probe 1	Yes	
Probe 2	Probe 2	Yes	
Input 3*	Probe / Run / Fault or Override*	Yes	0V return activates
Input 4*	Probe / Run / Fault or Override*	Yes	0V return activates
Input 5*	Probe / Run / Fault or Override*	Yes	0V return activates
Input 6*	Probe / Run / Fault or Override*	Yes	0V return activates
Digital Input 1	Probe / Run / Fault or Override*	Yes	0V return activates
Digital Input 1	Probe / Run / Fault or Override*	Yes	0V return activates
Relay 1	Configurable	N/A	See "Relay Contacts" Below
Relay 2	Configurable	N/A	See "Relay Contacts" Below
Relay 3	Configurable	N/A	See "Relay Contacts" Below
Relay 4	Configurable	N/A	See "Relay Contacts" Below
Relay 5	Configurable	N/A	See "Relay Contacts" Below

\* Inputs 3 to 6 and Digital Inputs 1 and 2 are configurable as either, a Probe, Run NO/NC, Fault NO/NC or Override NO/NC inputs.

The alarm relay is energised for no alarm. Use the NC and Common for "Loop make" on alarm or use the NO and Common for "Loop break" on alarm

## Relay Contacts

Heating : Use N/O Contact  
 Cooling : Use N/C Contact  
 Fan : Use N/C Contact  
 Timer : Use N/C Contact

## Ordering Information

When ordering the Mercury 3 controller the following ordering scheme can be used to purchase the desired hardware configuration. This ensures the controller ships with the optional hardware pre-fitted.

**PR0740 - X - Y - STA** Where **X** and **Y** is the selection from the tables below.

X	Description
232	RS232 Comms
IP	IP Interface

Y	Description
D	Local/ Integral Display
R	Remote Display

Example – To order a built in IP variant with a remote display, use the following part number:

PR0740-IP- R – STA



Please ensure all power is switched off before installing or maintaining this product.

## Setting up the controller

Access to the controller can be achieved several ways

- Through the front mounted buttons
- Direct access by PC or palm top into the rear comms port. This requires a software package available on the RDM website
- Through legacy front end panels on 485 networks
- Through the RDM Data Manager
- Across an IP network. (Current controller IP address required)

### Setup through front buttons



To enter setup mode, hold the Enter and Down buttons together for approximately 3 seconds until the message "Ent" appears on the display. Now press the Enter button again to enter the function menu. IO will be displayed. Scroll up or down to go through the list.

### Setup Function Menu (Common to all types)

Display	Option	Explained in Paragraph	Display	Option	Explained in Paragraph
IO	View Inputs / Outputs and States	<a href="#">Input / output table</a>	nEt	Set/view network configuration	<a href="#">Network Configuration</a>
PARA	Set/View Parameters	<a href="#">Set view parameters</a>	SoFt	View software version	
Unit	Probe type and Celsius/Fahrenheit option	<a href="#">Set View Unit</a>	OFSt	Probe Offset	<a href="#">Probe Offset</a>
diSP	Display whole units or decimal	<a href="#">Display</a>	tEst*	Test Mode	See Note Below
tyPE	Set/View Controller Type	<a href="#">Set/view controller type</a>	ESC	Exit Setup mode	
rtc	Set/view Clock (rtc = Real Time Clock)	<a href="#">Real Time Clock</a>			

**\*Note:** When first powered up the controller will have the 'tEst' option in the menu setup. This allows the user to toggle the relays for testing purposes. Upon entering the menu, the display will show r-01 (relay 1) to r-05 (relay 5), select the desired output and toggle the value from 0 to 1 (confirm by pressing enter) to switch the selected relay.

This option is only available for 30 seconds after power up. After this time, the menu setup will return to its standard options.



Please ensure all power is switched off before installing or maintaining this product.

## Recommended set-up method

If you are not connecting to a network and want to set up the controller through the buttons we recommend you use the following order from the function menu.

### rtc. Real time clock (This will automatically synchronise on network systems)

- a. Use the up or down buttons to scroll through the display until the display reads "rtc"
- b. Press enter. The display will show "t-1". press enter again
- c. Scroll hours up or down (0 – 23) press enter
- d. Use up button to select "t-2", press enter
- e. Scroll minutes up or down (0 – 59) press enter
- f. Repeat for t-3 (seconds 0 – 59)
- g. Repeat for t-4 (days up to 31)
- h. Repeat for t-5 (months up to 12)
- i. Repeat for t-6 (year up to 99)
- j. Use up button to display "ESC", press enter to display "rtc"

**Timeclock is now set**

### type. Set/view controller type

The controller type is preset at the factory and cannot be changed.

- a. From the function menu scroll to select type, press enter
- b. View type 1
- c. Press enter to return to the software menu

### Unit. Set/view temperature unit and Probe type

From the function menu scroll to select Unit  
Press enter and the value will be displayed:

0 for PT1000 Celsius	10 for NTC2K25 Celsius
1 for PT1000 Fahrenheit	11 for NTC2K25 Fahrenheit
2 for NTC2K Celsius	12 for 5K Celsius
3 for NTC2K Fahrenheit	13 for 5K Fahrenheit
4 for 470R Celsius	14 for 6K Celsius
5 for 470R Fahrenheit	15 for 6K Fahrenheit
6 for 700R Celsius	16 for NTC10K Celsius
7 for 700R Fahrenheit	17 for NTC10K Fahrenheit
8 for 3K Celsius	18 for NTC10K(2) Celsius (USA NTC10K)
9 for 3K Fahrenheit	19 for NTC10K(2) Fahrenheit (USA NTC10K)

Use the up or down keys to select the units and press enter. This function is now complete.

## Display

From the function menu scroll to and select diSP.

Press enter and one of the following values will be shown:

- 0 controller display will show the whole number and tenths value of a temperature reading.
- 1 controller display will show temperatures as a whole number.

Display defaults to 0.



Please ensure all power is switched off before installing or maintaining this product.

## PARA. Set/view parameters (This can be achieved at the network front end)

- From the function menu scroll to select PARA
- Pressing Enter while PARA is displayed will enter the parameter menu. The first parameter option will be displayed as P-01. Pressing the Up or Down button will present the other parameter options P-02, P-03 etc. See the parameter list below to find what parameter number corresponds to which actual parameter. Pressing the Enter button will show the current value of the selected parameter. Press Up or Down to modify the value and press Enter again to save the value. The parameter list number will be displayed again. Two other options are present in the parameter menu – dFLt and ESC. Selecting ESC will exit setup mode. Selecting dFLt will reset all parameters back to the default values for the current type controller.

## Parameter Table for Control Thermostat

Number	Parameter	Range °C ( °F )	Step	Units	Default
P-01	Set-point	-49 to 30°C (-56.2 to 86)	0.1	Deg	18.0
P-02	Upper Set-point limit	-49 to 30°C (-56.2 to 86)	0.1	Deg	23.0
P-03	Lower Set-point limit	-49 to 30°C (-56.2 to 86)	0.1	Deg	15.0
P-04	Heating 1 Diff (Below set-point)	0 to 20°C (0 to 36)	0.1	Deg	3.0
P-05	Heating 2 Diff (Below set-point)	0 to 20°C (0 to 36)	0.1	Deg	10.0
P-06	Cooling 1 Diff (Above set-point)	0 to 20°C (0 to 36)	0.1	Deg	3.0
P-07	Cooling 2 Diff (Above set-point)	0 to 20°C (0 to 36)	0.1	Deg	10.0
P-08	Control Weight	0 to 100	1	%	50
P-09	Display Weight	0 to 100	1	%	50
P-20	Frost Detect Enable	0 = off, 1 = on	1		0
P-21	Frost Probe	0 = Probe 1, 1 = Probe 2, 2 = Probe 3, 3 = Probe 4, 4 = Probe 5 5 = Probe 6, 6 = Control	1		6
P-22	Frost Detect Set-point	-49 to 30°C (-56.2 to 86)	0.1	Deg	0.0
P-23	Frost Diff (Above Frost set-point)	0 to 20°C (0 to 36)	0.1	Deg	6
P-30	Fans Mode	0 = On, 1 = Follows Timer	1		0
P-31	Fans Run	0 = Off, 1 = Low, 2 = Medium, 3 = High, 4 = Auto	1		4
P-32	Fans Run-on	00:00 to 99:00	01:00	mm:ss	20:00
P-40	Heating Stage Delay	00:00 to 99:00, 00:00 = Not Used	01:00	mm:ss	05:00
P-41	Cooling Stage Delay	00:00 to 99:00, 00:00 = Not Used	01:00	mm:ss	05:00
P-42	Over-ride alarm delay	00:00 to 99:00	01:00	mm:ss	05:00
P-43	OT/UT Alarm Delay	00:00 to 99:00	01:00	mm:ss	20:00
P-44	Under temperature Alarm	-98 to 128°C (-144.4 to 262.4)	0.1	Deg	0.0
P-45	Over Temperature Alarm	-98 to 128°C (-144.4 to 262.4)	0.1	Deg	25.0
P-50	Input 3	0 = Unused, 1 = Probe, 2 = Run NO, 3 = Run NC, 4 = Fault NO 5 = Fault NC, 6 = Over-ride NO, 7 = Over-ride NC	1		0
P-51	Input 4	0 = Unused, 1 = Probe, 2 = Run NO, 3 = Run NC, 4 = Fault NO 5 = Fault NC, 6 = Over-ride NO, 7 = Over-ride NC	1		0
P-52	Input 5	0 = Unused, 1 = Probe, 2 = Run NO, 3 = Run NC, 4 = Fault NO 5 = Fault NC, 6 = Over-ride NO, 7 = Over-ride NC	1		0
P-53	Input 6	0 = Unused, 1 = Probe, 2 = Run NO, 3 = Run NC, 4 = Fault NO 5 = Fault NC, 6 = Over-ride NO, 7 = Over-ride NC	1		0
P-54	Relay 1 Mode*	0 = Off, 1 = Heating stage 1, 2 = Heating stage 2, 3 = Cooling stage 1, 4 = Cooling stage 2, 5 = Fan, 6 = Timer	1		0



Please ensure all power is switched off before installing or maintaining this product.

Number	Parameter	Range °C ( °F )	Step	Units	Default
		7 = Alarm			
P-55	Relay 2 Mode*	0 = Off, 1 = Heating stage 1, 2 = Heating stage 2, 3 = Cooling stage 1, 4 = Cooling stage 2, 5 = Fan, 6 = Timer 7 = Alarm	1		0
P-56	Relay 3 Mode*	0 = Off, 1 = Heating stage 1, 2 = Heating stage 2, 3 = Cooling stage 1, 4 = Cooling stage 2, 5 = Fan, 6 = Timer 7 = Alarm	1		0
P-57	Relay 4 Mode*	0 = Off, 1 = Heating stage 1, 2 = Heating stage 2, 3 = Cooling stage 1, 4 = Cooling stage 2, 5 = Fan, 6 = Timer 7 = Alarm	1		0
P-58	Relay 5 Mode*	0 = Off, 1 = Heating stage 1, 2 = Heating stage 2, 3 = Cooling stage 1, 4 = Cooling stage 2, 5 = Fan, 6 = Timer 7 = Alarm	1		0
P-59	Digital Input 1	0 = Unused, 1 = Probe, 2 = Run NO, 3 = Run NC, 4 = Fault NO 5 = Fault NC, 6 = Over-ride NO, 7 = Over-ride NC			
P-60	Digital Input 2	0 = Unused, 1 = Probe, 2 = Run NO, 3 = Run NC, 4 = Fault NO 5 = Fault NC, 6 = Over-ride NO, 7 = Over-ride NC			
P-70	Timer Mode	0 = Local, 1 = Remote, 2 = Man Off, 3 = Man On	1		0
P-71	Sunday On Time 1	00:00 to 23:59	00:01	hh:mm	08:00
P-72	Sunday Off Time 1	00:00 to 23:59	00:01	hh:mm	20:00
P-73	Sunday On Time 2	00:00 to 23:59	00:01	hh:mm	08:00
P-74	Sunday Off Time 2	00:00 to 23:59	00:01	hh:mm	20:00
P-75	Monday On Time 1	00:00 to 23:59	00:01	hh:mm	08:00
P-76	Monday Off Time 1	00:00 to 23:59	00:01	hh:mm	20:00
P-77	Monday On Time 2	00:00 to 23:59	00:01	hh:mm	08:00
P-78	Monday Off Time 2	00:00 to 23:59	00:01	hh:mm	20:00
P-79	Tuesday On Time 1	00:00 to 23:59	00:01	hh:mm	08:00
P-80	Tuesday Off Time 1	00:00 to 23:59	00:01	hh:mm	20:00
P-81	Tuesday On Time 2	00:00 to 23:59	00:01	hh:mm	08:00
P-82	Tuesday Off Time 2	00:00 to 23:59	00:01	hh:mm	20:00
P-83	Wednesday On Time 1	00:00 to 23:59	00:01	hh:mm	08:00
P-84	Wednesday Off Time 1	00:00 to 23:59	00:01	hh:mm	20:00
P-85	Wednesday On Time 2	00:00 to 23:59	00:01	hh:mm	08:00
P-86	Wednesday Off Time 2	00:00 to 23:59	00:01	hh:mm	20:00
P-87	Thursday On Time 1	00:00 to 23:59	00:01	hh:mm	08:00
P-88	Thursday Off Time 1	00:00 to 23:59	00:01	hh:mm	20:00
P-89	Thursday On Time 2	00:00 to 23:59	00:01	hh:mm	08:00
P-90	Thursday Off Time 2	00:00 to 23:59	00:01	hh:mm	20:00
P-91	Friday On Time 1	00:00 to 23:59	00:01	hh:mm	08:00
P-92	Friday Off Time 1	00:00 to 23:59	00:01	hh:mm	20:00
P-93	Friday On Time 2	00:00 to 23:59	00:01	hh:mm	08:00
P-94	Friday Off Time 2	00:00 to 23:59	00:01	hh:mm	20:00
P-95	Saturday On Time 1	00:00 to 23:59	00:01	hh:mm	08:00
P-96	Saturday Off Time 1	00:00 to 23:59	00:01	hh:mm	20:00
P-97	Saturday On Time 2	00:00 to 23:59	00:01	hh:mm	08:00
P-98	Saturday Off Time 2	00:00 to 23:59	00:01	hh:mm	20:00
dFLt	Factory Defaults				

\* At least one relay output must be selected as a fan before the thermostat control will operate. This is a precautionary measure to prevent the user from enabling a heater without the appropriate fan(s) being selected as in some applications this could damage the heating equipment or cause a fire hazard.



Please ensure all power is switched off before installing or maintaining this product.

## Parameter Descriptions

Number	Parameter	Description
P-01	Set-point	Thermostat target temperature. Point at which heating 1 or cooling 1 will switch off.
P-02	Upper Set-point limit	Maximum upper temperature limit the user can adjust the set point too via the quick key feature on the controller display. (Using the up and down button)
P-03	Lower Set-point limit	Maximum lower temperature limit the user can adjust the set point range via the quick key feature on the controller display. (Using the up and down button)
P-04	Heating 1 Diff (Below set-point)	Differential temperature below the set-point temperature. The first heating stage switches on when this temperature is reached.
P-05	Heating 2 Diff (Below set-point)	Differential temperature below the set-point temperature. The second heating stage switches on when this temperature is reached.
P-06	Cooling 1 Diff (Above set-point)	Differential temperature above the set-point temperature. The first cooling stage switches on when this temperature is reached.
P-07	Cooling 2 Diff (Above set-point)	Differential temperature above the set-point temperature. The second cooling stage switches on when this temperature is reached.
P-08	Control Weight	Percentage of Probe 1 temperature that is used to calculate the control temp. The remaining percentage will be used on Probe 2 temperature Example, P-08 set to 30% Control temp = 30% Probe 1 + 70% Probe 2
P-09	Display Weight	As above only applied to the display temperature
P-20	Frost Detect Enable	Enables the frost detect feature.
P-21	Frost Probe	Allows user to define the source of the temperature used with frost detect.
P-22	Frost Detect Set-point	Set-point at which the heating element will switch on when the temperature drops below the frost detect set point, providing the feature has been enabled.
P-23	Frost Diff (Above Frost set-point)	Differential temperature above the set-point temperature. The heating element switches off when above this temperature
P-30	Fans Mode	<ul style="list-style-type: none"> <li>➤ Always on where the fans are never turned off.</li> <li>➤ Follows timer on/off status. When the fans are in the off period the thermostat operation is disabled. Note the parameter "Fans Run-on" will have an effect on the fans status.</li> </ul>
P-31	Fans Run	<p>Determines fan operation:</p> <ul style="list-style-type: none"> <li>➤ Off</li> <li>➤ Low</li> <li>➤ Medium</li> <li>➤ High</li> <li>➤ Auto</li> </ul> <p>If three relays are selected as fans then when set to low 1 fan would be on, medium equals 2 fans on and high would turn on all three fans. If set to auto, the software fuzzy logic will allocate the best speed for the control temperature. If set to "Off" then this will stop the fans and thermostat operation.</p>
P-32	Fans Run-on	The period of time for which the fans remain on after the timer/thermostat has been turned off.
P-40	Heating Stage Delay	Time delay before heating stage 2 is turned on once below the set point. Please note the heating stage is turned on when either the delay time expires or the temperature drops below heating 2 diff set point whichever occurs first.
P-41	Cooling Stage Delay	Time delay before cooling stage 2 is turned on once above the set point. Please note the cooling stage is turned on when either the delay time expires or the temperature rises above cooling 2 diff set point whichever occurs first.
P-42	Over-ride alarm delay	When an over-ride is initiated an alarm is generated. A delay can be added before signalling the alarm. This delay does not apply when the input is set as fault input.
P-43	OT/UT Alarm Delay	Delay applied before an alarm is signalled for an over/under temperature alarm.
P-44	Under temperature Alarm	Under temperature alarm set point. This alarm uses the control temperature.
P-45	Over Temperature Alarm	Over temperature alarm set point. This alarm uses the control temperature
P-50	Input 3	<ul style="list-style-type: none"> <li>➤ Unused – Input has no function.</li> <li>➤ Probe - Used for monitoring purposes or as frost probe. This configuration has no alarm function.</li> <li>➤ Run NO (Normally Open) – Thermostat requires run signal before it will operate.</li> <li>➤ Run NC (Normally Closed) - Thermostat requires run signal before it will operate.</li> </ul>



Please ensure all power is switched off before installing or maintaining this product.

Number	Parameter	Description
		<ul style="list-style-type: none"> <li>➤ Fault NO (Normally Open) – Generate an alarm to indicate a fault.</li> <li>➤ Fault NC (Normally Closed) - Generate an alarm to indicate a fault.</li> <li>➤ Over-ride NO</li> <li>➤ Over-ride NC</li> </ul>
P-51	Input 4	As above.
P-52	Input 5	As above.
P-53	Input 6	As above.
P-54	Relay 1 Mode	<ul style="list-style-type: none"> <li>➤ Off – Relay has no operation</li> <li>➤ Heating stage 1 – Operates in relation to heating diff 1 and the controller set-point.</li> <li>➤ Heating stage 2 - Operates in relation to heating diff 2 and the controller set-point.</li> <li>➤ Cooling stage 1 - Operates in relation to cooling diff 1 and the controller set-point.</li> <li>➤ Cooling stage 2 - Operates in relation to cooling diff 2 and the controller set-point.</li> <li>➤ Fan – Operation dependant on parameter "Fans Mode", "Run on" and "Fans Run".</li> <li>➤ Timer – Relay operation follows the timer on/off status.</li> <li>➤ Alarm – When enabled the alarm relay is energised for no alarm. When an alarm condition occurs the relay will de-energise. Please see <a href="#">Alarm Relay Action</a> table for conditions.</li> </ul>
P-55	Relay 2 Mode	As above.
P-56	Relay 3 Mode	As above.
P-57	Relay 4 Mode	As above.
P-58	Relay 5 Mode	As above.
P-59	Digital Input 1	See P-50
P-60	Digital Input 2	See P-50
P-70	Timer Mode	<ul style="list-style-type: none"> <li>➤ Use a local schedule following the controller RTC (P-71 to P-98)</li> <li>➤ Use a remote schedule (Set up in the system front end)</li> <li>➤ Always Off</li> <li>➤ Always On</li> </ul>
P-71	Sunday On Time 1	When P-70 is set to Local, Sunday on time 1
P-72	Sunday Off Time 1	When P-70 is set to Local, Sunday off time 1
P-73	Sunday On Time 2	When P-70 is set to Local, Sunday on time 2
P-74	Sunday Off Time 2	When P-70 is set to Local, Sunday off time 2
P-75	Monday On Time 1	When P-70 is set to Local, Monday on time 1
P-76	Monday Off Time 1	When P-70 is set to Local, Monday off time 1
P-77	Monday On Time 2	When P-70 is set to Local, Monday on time 2
P-78	Monday Off Time 2	When P-70 is set to Local, Monday off time 2
P-79	Tuesday On Time 1	When P-70 is set to Local, Tuesday on time 1
P-80	Tuesday Off Time 1	When P-70 is set to Local, Tuesday off time 1
P-81	Tuesday On Time 2	When P-70 is set to Local, Tuesday on time 2
P-82	Tuesday Off Time 2	When P-70 is set to Local, Tuesday off time 2
P-83	Wednesday On Time 1	When P-70 is set to Local, Wednesday on time 1
P-84	Wednesday Off Time 1	When P-70 is set to Local, Wednesday off time 1
P-85	Wednesday On Time 2	When P-70 is set to Local, Wednesday on time 2
P-86	Wednesday Off Time 2	When P-70 is set to Local, Wednesday off time 2
P-87	Thursday On Time 1	When P-70 is set to Local, Thursday on time 1
P-88	Thursday Off Time 1	When P-70 is set to Local, Thursday off time 1
P-89	Thursday On Time 2	When P-70 is set to Local, Thursday on time 2
P-90	Thursday Off Time 2	When P-70 is set to Local, Thursday off time 2
P-91	Friday On Time 1	When P-70 is set to Local, Friday on time 1
P-92	Friday Off Time 1	When P-70 is set to Local, Friday off time 1
P-93	Friday On Time 2	When P-70 is set to Local, Friday on time 2
P-94	Friday Off Time 2	When P-70 is set to Local, Friday off time 2
P-95	Saturday On Time 1	When P-70 is set to Local, Saturday on time 1
P-96	Saturday Off Time 1	When P-70 is set to Local, Saturday off time 1
P-97	Saturday On Time 2	When P-70 is set to Local, Saturday on time 2



Please ensure all power is switched off before installing or maintaining this product.

Number	Parameter	Description
P-98	Saturday Off Time 2	When P-70 is set to Local, Saturday off time 2
dFLt	Factory Defaults	Restores all of the parameters to their default values

## Network Configuration – RS232 comms

The final section to setup is the network address. In all instances, this must be done before the controller is connected to the site network.

When logging a Mercury 3 with an RS232 interface onto a network you must first connect the controller to a communications module, this is either a 485 Legacy, IP Futura, Mercury Switch or Wireless Mesh Interface. For Mercury 3's with the IP interface please refer to the [Network Configuration – IP comms](#) section for details of networking.

## RS485 Legacy module

Using RS485, the controllers have an auto-initialise function, which will automatically log the device onto the site network. If the wrong address has been entered onto the network, you will have to reset the controller address by setting the address to 00-0, and then re-enter the correct address (you may have to deregister the wrong address from the home system as well).

Connecting an RS485 legacy Module to the controller will govern which set-up screens are made available in the '**Net**' menu. The module will support the "Genus" protocol only. Using RS485 will show the below:

Display	Option
485t	485 Network Type
485A	485 Address/ Name
gAdd	Show underlying network address assigned to controller
rLog	Re-log the controller back onto the network
ClrA	Clear the address/name from the controller
ESC	Exit network menu. <b>N.B.</b> this option <b>must</b> be selected to save any changes made in this menu

The **485t** option shows a value representing the network type. The possible values are:

Value	Network Type
1	Genus compatible (all versions)
2	RDM Wireless Mesh System (Wireless Mesh)

Ensure option '1' is selected (for RS485).

The **485A** option shows a value representing the name of the controller in a Genus compatible network. For example, if the value shown in 485A is shown as "05-6". The controller would try to log onto a Genus compatible network using the name 'RC05-6'.

The **gAdd** option displays (in hexadecimal format) the underlying network address assigned to the controller when it was logged onto the network. Note: this is automatically assigned by the Data Manager.

The **rLog** option allows the controller to be logged back onto the network with its current name. The 'rLog' message will flash, waiting for confirmation. To confirm, press the Enter button to execute the command, Up or Down buttons to cancel.

The **CLrA** option will clear out the network address and name in the controller. The 'ClrA' message will flash for confirmation. Press the Enter button to execute the command, Up or Down buttons to cancel.



Please ensure all power is switched off before installing or maintaining this product.

## Fast Network Address Reset

To enter this mode, hold the Enter, Up and Down buttons together for approximately 3 seconds until the message CLrA appears on the display. CLrA is the first option in the menu consisting of the following options:

Display	Option
CLrA	Clear the address/name from the controller
ESC	Exit Setup mode

Pressing the Enter button to select the CLrA option will cause the 'CLrA' message to flash for confirmation, if the network type is set to Genus compatible. Press the Enter button to execute the command, Up or Down buttons to cancel. If the network type is not set to Genus compatible then the CLrA message will not flash and the ESC option can be used to exit the menu.

## Wireless Mesh Module

When a wireless mesh module is connected to the controller the 'Net' menu will show similar options to that of the 'RS485' network. The only difference to the settings would be that the **485t** should be set for **'2'**. Then the same steps should be taken to that of the RS485 option to log the unit on to the wireless mesh. Note, the wireless mesh network should already be set up on the data manager. Please see the Data Manager documentation for setup instructions. Furthermore, please see documentation on the PR0730 Wireless Mesh Network Module for setup instructions.

## IP Futura module

In an IP system there are two options:

- IP-L
- IP-r

IP-L allows you to fix a static IP address into the controller, which you would use when you are connecting the controllers onto a customer's local area network. This would allow the customer to view each controller using a generic Internet browser.

IP-r allows you to give each controller on the system a unique number (using the rotary switches). This number is then allocated a dynamic IP address by the system's DHCP server (such as the RDM Data Manager).

## IP-L

To configure the communication module, set all three rotary switches to zero. The module should then be connected to the controller.

- From the function menu you can now select '**nEt**'.
- Press enter and the display will show "IP-L", press enter once more.
- You can now set the IP network settings by using the table below

Display	Option
IP-1	IP Address byte 1
IP-2	IP Address byte 2
IP-3	IP Address byte 3
IP-4	IP Address byte 4
nL	Network Mask Length
gt-1	Gateway Address byte 1
gt-2	Gateway Address byte 2
gt-3	Gateway Address byte 3
gt-4	Gateway Address byte 4
ESC	Exit network menu. <b>N.B.</b> this option <b>must</b> be selected to save any changes made in this menu



Please ensure all power is switched off before installing or maintaining this product.

## IP-r

To configure the communication module for IP-r, set the three rotary switches to give each controller a unique identifier. The module should then be connected to the controller and the network. The controller should then be powered on to connect to the network.

- From the function menu you can now select 'nEt'
- Press enter and the display will show "IP-r", press enter once more.
- You can now view (only) the address given by the DHCP server.

## Network Mask Length

To ease setup, a single network mask length value is used. If the address has been specified with a network mask value in dotted IP format e.g. 255.255.255.0 then the table below gives the conversion:

Mask	Length	Mask	Length	Mask	Length
255.255.255.252	30	255.255.254.0	23	255.254.0.0	15
255.255.255.248	29	255.255.252.0	22	255.252.0.0	14
255.255.255.240	28	255.255.248.0	21	255.248.0.0	13
255.255.255.224	27	255.255.240.0	20	255.240.0.0	12
255.255.255.192	26	255.255.224.0	19	255.224.0.0	11
255.255.255.128	25	255.255.192.0	18	255.192.0.0	10
255.255.255.0	24	255.255.128.0	17	255.128.0.0	09
		255.255.0.0	16	255.0.0.0	08

## Mercury Switch

The method of logging on the Mercury 3 (RS232 comms) will be similar to that of the IP Futura however please refer to the Mercury Switch user guide, which can be obtained from the RDM website, for information regarding connecting a controller to a network.

## Network Configuration – IP comms

Mercury 3 controllers with the IP interface as standard does not require any communications module and will already communicate on the IP network protocol.

When networking the Ethernet variant, the 'Net' menu will have the following menus:

Display	Option
IP-L / IP-r	Read/ Write Static IP address / Read Only DHCP IP address
Id	The 3 digit network address
AtyP	IP-r / IP-L selection
ESC	Exit Menu

Similar to the IP Futura/switch setup IP-L allows you to fix a static IP address into the controller and IP-r allows you to give each controller on the system a unique network number (using the Id).

- To firstly select between IP-L and IP-r navigate to 'AtyP'.

## IP-r

Once IP-r is selected the controller must be given a unique 3 digit 'network address' that no other device on the network has (note if logging on to a Data Manager, this will be the device ID). Once the ID has been set connect the controller to the IP network for it then to be given an IP address by the DHCP server. To view the IP address given, within the Net menu, navigate to 'IP-r'.



Please ensure all power is switched off before installing or maintaining this product.

## IP-L

If IP-L has been selected from the 'AtyP' menu the IP address must be given to the controller by navigating to 'IP-L' within 'Net'. The following menus will be available:

Display	Option
IP-1	IP Address byte 1
IP-2	IP Address byte 2
IP-3	IP Address byte 3
IP-4	IP Address byte 4
nL	Network Mask Length (see the <a href="#">network mask length</a> table above)
gt-1	Gateway Address byte 1
gt-2	Gateway Address byte 2
gt-3	Gateway Address byte 3
gt-4	Gateway Address byte 4
ESC	Exit network menu. <b>N.B.</b> this option <b>must</b> be selected to save any changes made in this menu

Once the IP address has been entered, the controller can be connected to the IP network.

## Viewing

Apart from setting up the controller, you can also view the status of the inputs and outputs and controller states.

From the function menu, select "I/O", press enter. You can now scroll through the IO table as set out below.

## Input / Output Table

Number	IO	Range*	Step	Units
I-01	Control temp	-98 to 128 °C	0.1	Deg
I-02	Display temp	-98 to 128 °C	0.1	Deg
I-10	Probe 1	-98 to 128 °C	0.1	Deg
I-11	Probe 2	-98 to 128 °C	0.1	Deg
I-12	Probe 3	-98 to 128 °C	0.1	Deg
I-13	Probe 4	-98 to 128 °C	0.1	Deg
I-14	Probe 5	-98 to 128 °C	0.1	Deg
I-15	Probe 6	-98 to 128 °C	0.1	Deg
I-20	Run Signal	0 (Off), 1 (On), 2 (Unused)		
I-21	Fault Signal	0 (Alarm), 1 (Ok), 2 (Unused)		
I-22	Over-ride	0 (Off), 1 (On), 2 (Unused)		
O-01	Relay 1	0 (Off), 1 (On)		
O-02	Relay 2	0 (Off), 1 (On)		
O-03	Relay 3	0 (Off), 1 (On)		
O-04	Relay 4	0 (Off), 1 (On)		
O-05	Relay 5	0 (Off), 1 (On)		
O-06	Timer	0 (Off), 1 (On)		
O-07	Set Point	-49 to 30 °C	0.1	Deg
O-08	Frost Probe	-49 to 30 °C	0.1	Deg
S-01	Control State	0 (Stabilise), 1 (Normal), 2 (OT Alarm), 3 (UT Alarm), 5 (PrbFail)		



Please ensure all power is switched off before installing or maintaining this product.

## Display Messages

The following alarms and messages can appear on the Mercury.

Display Message	System status
Ot	Over Temperature Alarm
Ut	Under Temperature Alarm
AL	Control State in Alarm
Ft	Control Fault
Prb	Probe Fault

## Network Alarms

The table below shows the text and associated type number that is sent to the system "front end". The type number is normally used to provide different alarm actions.

Alarm text	Type # (index)
Over-ride Alarm	16
Over Temperature	4
Under Temperature	5

Alarm text	Type # (index)
Control Probe	6
Fault Signal	6
Run Signal	3

## Normal Operation

During normal operation, the controller will show the display temperature, if there are no alarms. If there is a current alarm then an alarm message will be shown on the display. If the fans are operating the fans symbol will be lit. If the Control Stat is on a network and on-line, the green network LED will be on.



## Faults

If a fault is detected, the Control Stat will indicate the fault on the display and the red alarm LED will come on.

## Network

The Network green LED flashes if the controller goes off-line or loses its given address.

## Probe Offset

This feature allows each probe value to be modified by an "offset". Offset values are from -10°C (-18°F) to +10°C (+18°F) and on a channel basis. Example C1 = Probe 1.

## Set Point

The current setpoint can be viewed and adjusted by pressing the Up and Down arrows together. The limits of the adjustments are set in the controller (P-2 & P-3). Set point can be viewed from a front-end via the values page or Communicator software or from the controller IO.

## Valve Symbol

The valve symbol on the controller display indicates the current operational status of the controller. If "Fans Mode" is set to "Timed", and the symbol is present, then it implies that the timer is in the off period and therefore there will be no fan/thermostat operation. When the valve symbol is off then the timer is in the on



Please ensure all power is switched off before installing or maintaining this product.

period and the fan/thermostat will follow its normal control strategy. If "Fans Mode" is set to "On" then the valve symbol will be permanently off and the fans/thermostat control strategy will operate continuously.

### Operation

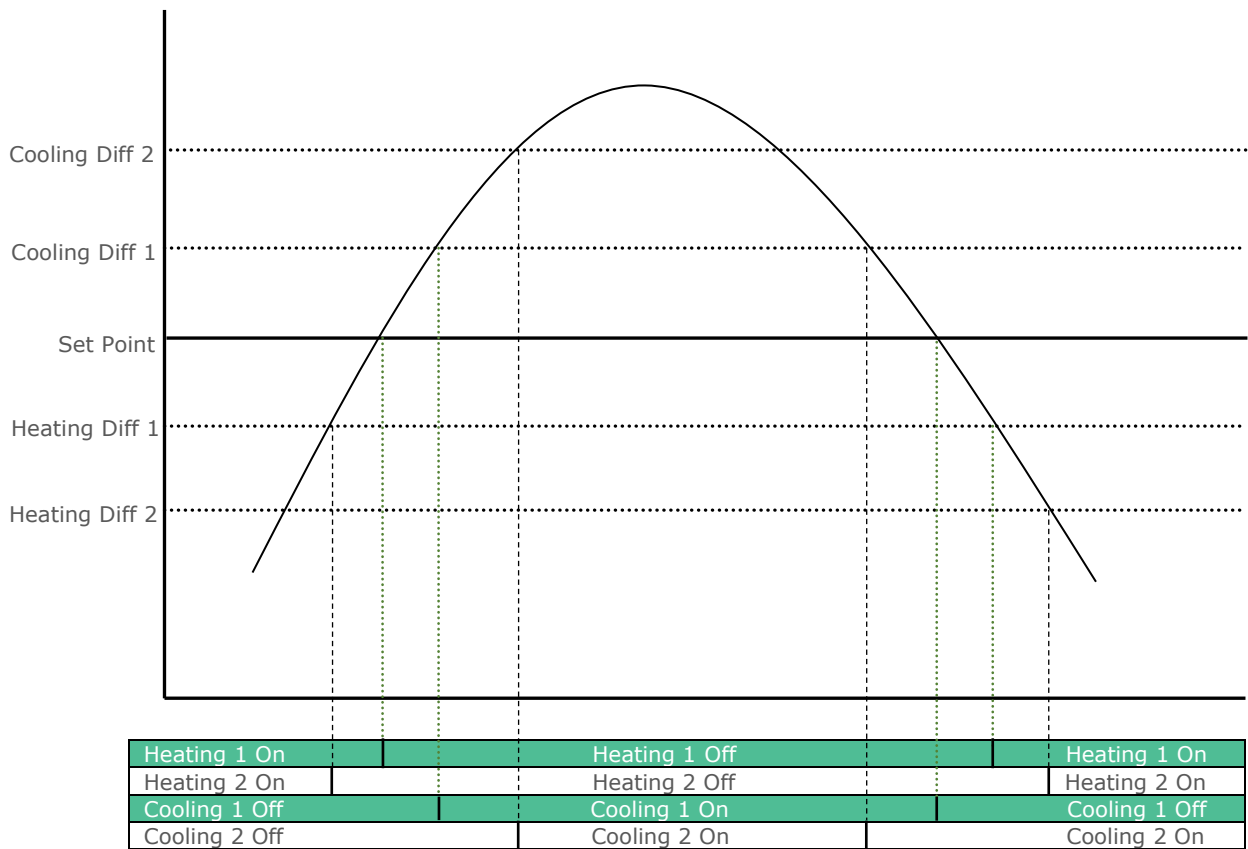

The thermostat will operate to the above graph during the on times of the timer (either local or remote). It is possible to turn the timer permanently on therefore the thermostat would run continuously. With the timer configured for local operation, set both on times 1 & 2 to 00:00 and both off times 1 & 2 to 23:59 on the desired days. With an input selected as either Run N/C (normally closed) or Run N/O (normally open) the thermostat would require a run signal before it will operate. If no input is configured then the run feature is disabled. Heating and cooling stage 2 can be configured to come on at a pre-determined temperature or after a time delay.

During normal operation, the up and down keys can be used to adjust the current operating set point, limited by the upper and lower set-point settings. Press and hold both the up and down keys until the service icon, the spanner symbol, is displayed. The value shown on the screen is the current temperature set point, use the up or down button to adjust the set point. Hit the enter button when complete to save and exit. Note this will not change the parameter "Set Point" it will only allow the user to change the current operating set point. Once adjusted the stat will continue to control to this set point until the controller is either power cycled or the process is followed to adjust the operating set point back to the previous set point. If the current control set point has been adjusted via this process and the parameter "Set Point" is then adjusted then the offset will still remain and is added/subtracted to the new set point. E.g. Parameter "Set Point" is set to 16. The above process is used to adjust the operating set point to 18. The parameter "Set Point" is now changed to 17. The operating set point will now be 19 (set point 17 + 2 offset through up/down buttons).

The controller has 2 probe inputs that can be used together (weighted) to form the control temperature, or the controller can be configured to use 1 probe only. Setting control weight to 100% would use only probe 1. 0% would use only probe 2 for control. 50% would use an average of probe's 1&2.

The fan(s) will run continuously when the controller is operational, even if the temperature is in the dead zone where no cooling or heating relays are on. When more than 1 fan has been selected as outputs, the fans can be set to Low, medium, high or Auto. If set to auto, the software fuzzy logic will allocate the best speed for the control temperature. On the low, medium or high setting, these can be cycled by pressing and holding the controller # key. When the spanner icon appears on the display the current fans mode will be shown.



Please ensure all power is switched off before installing or maintaining this product.

If fans mode is set to remote, a GP timer channel must be set up for the fans to run. Note, if the fans go off, the cooling and heating functions will also be turned off. A fans run-on function is available to keep the fans running for a pre-determined period after the off command has been received.

During the heating cycle, heating stage 1 will come on, then heating stage 2 will come on after a delay period or if the temperature reaches the set point (parameter: - Heating Stage 2 delay)

The alarm relay will come on during any alarms or faults.

The over-ride input will do the following: -

If the thermostat timer is on, it will disable the thermostat function until the next timer on time.

If the thermostat timer is off, it will turn the thermostat function on until the next timer off time.

An over-ride off delay can be set to give a delay from the over-ride input to the actual off.

If frost detect has been enabled, irrespective of the controllers other settings, if the temperature falls below the frost set-point, the controller starts heating up to the frost diff point, where the heating relay(s) will go off.

**Note:** - At least one relay output must be selected as a fan before the thermostat control will operate. This is a precautionary measure to prevent the user from enabling a heater without the appropriate fan(s) being selected as in some applications this could damage the heating equipment.

## Relay Actions

Relays configured for "Heating" are energised for on, relays configured for "Cooling" or "Fan" are de-energised for on. (Therefore do not use Relay 5 for cooling or fan operation, as only the N/O is available.)

## Alarm Relay Action

The alarm relay has its' common, NO and NC contacts available for use.

This relay will normally be energised (no alarm) and be de-energised when an alarm occurs (after the alarm delay time-out)

The table below shows the Alarm relay action

State	Alarm Delay	Alarm Relay
Probe Fault	Fixed 10 Seconds	✓
Run Signal	Fixed 10 Seconds	✓
Under temperature	Variable (parameter)	✓
Over temperature	Variable (parameter)	✓
General Fault	Variable (parameter)	✓
Over-ride	Variable (parameter)	✓

## GP Timer Set-up

It is possible to set the Control Stat timer for remote operation (P70 = 1). A GP Timer must be set up to control the timer on/off period. For GP Timer set up please refer to the Data Manager user guide found on the RDM website. The following settings should be followed: -

- Output Type - This should be set to "General".
- Output Mask - This should match the "Controller Name".
- Output Channel - Set this to "5". This will allow the GP Timer to control the state of the controller timer.



Please ensure all power is switched off before installing or maintaining this product.

## Remote Commands

The following commands can be used by a Data Builder program:

Command	Value to send	Description	Conditions
Haccp Command	0	HACCP LED OFF	
	1	HACCP LED On	
	2	HACCP LED Flashes	
Button Command	0	Buttons backlights Off	
	1	Buttons backlights On	
	2	Buttons Backlights Flash	

Use an "Analogue Out" block configured to the controller name and in the value field type in the command you require. Use a "Setting block" as the input to the "Analogue Out" block to send the Value.

**Set Block 1**

Name: CROOM1

Type: Analog  Internal

Settings:

Value: 1

Min: 0

Max: 2

Units: None

OK Cancel

Java Applet Window



**Analog Output 2**

Name: HACCP

Units: None  Internal

Output Mapping:

Type: Network

Device: CROOM1

Value: Haccp Comman

Note: Fixed outputs are only selectable if they do not conflict with DM / DD settings and are not being used by another IO block.

OK Cancel

Java Applet Window



Please ensure all power is switched off before installing or maintaining this product.

## Specification

Mercury Mk3 Controller PR0710-STA	
<b>Power Requirements</b>	
<b>Supply Voltage Range</b>	100 - 240 Vac $\pm$ 10%
<b>Supply Frequency</b>	50 - 60 Hz
<b>Maximum supply current</b>	5.2 Amps (when relay 5 is fully loaded)
<b>Typical supply current</b>	<1 Amp
<b>General</b>	
<b>Operating temperature range</b>	-10°C to 60°C (14°F to 140°F)
<b>Storage temperature range</b>	-20°C to 65°C (-4°F to 149°F)
<b>Environmental</b>	Indoor use at altitudes up to 2000m, pollution degree 1, installation category II. Voltage fluctuations not to exceed $\pm$ 10% of nominal voltage.
<b>Size</b>	78mm (W) x 36mm (H) x 110mm (D)
<b>Approx Weight</b>	170 grams
<b>Safety</b>	EN61010
<b>EMC</b>	EN61326:2013
<b>Ventilation</b>	There is no requirement for forced cooling ventilation
<b>Class 2 Insulation</b>	<b>No</b> protective Earth is required and <b>none</b> should be fitted
<b>Supply Fuse</b>	The host equipment must provide a suitable external over-current protection device such as: - Fuse: 6.3A 240 Vac Antisurge (T) HRC conforming to IEC 60127
<b>Or MCB</b>	6A, 240 VAC Type C conforming to BS EN 60898
<b>Relay Fuse</b>	Not Fitted
<b>Relay Specification</b>	
<b>Relays 1-4 Exclusive common</b>	
<b>Max current</b>	6A Resistive ( $\text{Cos}\phi = 1$ ) 2A Inductive ( $\text{Cos}\phi = 0.4$ )
<b>Max voltage</b>	250Vac, 30V dc
<b>Relay Fuse</b>	N/A
<b>Relay 5 Exclusive common</b>	
<b>Max current</b>	3A (non inductive), $\text{COS}\phi=0.4$ 2A (inductive load) 200,000 operations
<b>Max voltage</b>	250Vac (Internal supply)
	For compliance with the LVD, relays 3, 4 and 5 commons must be at the same potential as the supply voltage
<b>Inputs</b>	
Input resistance	3.01K Ohms (for PTC or NTC type probes)
Input type	PT1000 or NTC2K or NTC2K25 or NTC10K (selectable)
<b>Comms</b>	
Serial Variant	RS232 with flow control
Ethernet Variant	IP comms



Please ensure all power is switched off before installing or maintaining this product.

## Installation

### Panel Cut-out and Clearances

#### Mercury Mk3 (Flush mount controller)

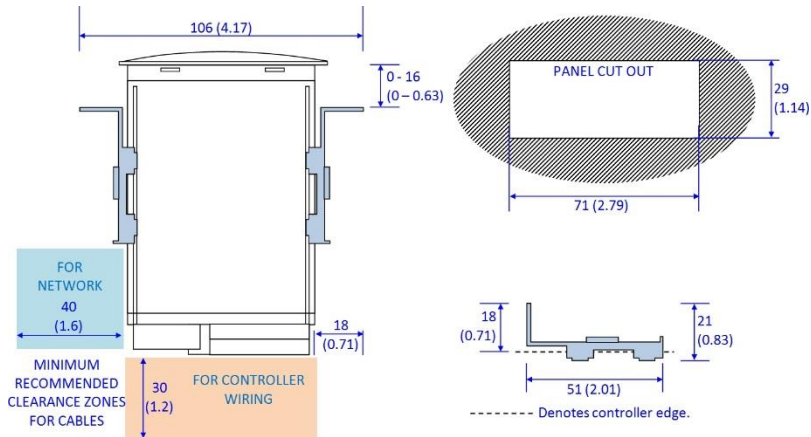

### Fixing

The controller is fixed by sliding the 2 plastic retaining clips up to rear of the panel. These clips have a ratchet action and can be removed by holding in the clip sides and sliding back.

There is no requirement for forced cooling ventilation

## Dimensions

### Mercury Mk3

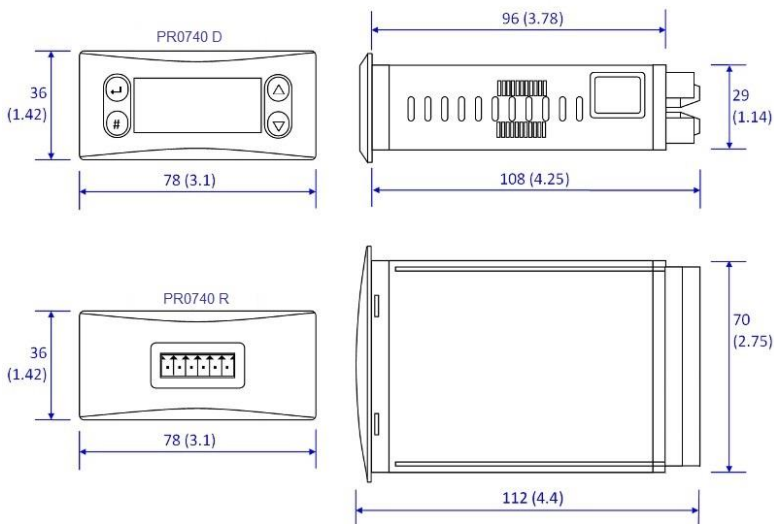

### Cleaning

Do not wet the controller when cleaning. Clean the front by wiping with slightly dampened lint free cloth.



Please ensure all power is switched off before installing or maintaining this product.

## Disclaimer

The specifications of the product detailed in this document may change without notice. RDM Ltd shall not be liable for errors or omissions, for incidental or consequential damages, directly or indirectly, in connection with the furnishing, performance or misuse of this product or document.

## Revision History

Revision	Date	Changes
3.0	24/03/16	Introduction Mercury Mk3 range
3.0a	14/03/2017	New documentation format.
3.0b	17/05/2017	Operating temperature amended.
3.0c	31/05/2019	I/O table updated, Contact details updated.



Please ensure all power is switched off before installing or maintaining this product.

## Group Offices

### RDM Group Head Office

80 Johnstone Avenue  
Hillington Industrial Estate  
Glasgow  
G52 4NZ  
United Kingdom

+44 (0)141 810 2828  
[support@resourcedm.com](mailto:support@resourcedm.com)

### RDM USA

9441 Science Center Drive  
New Hope  
Minneapolis, MN  
55428  
United States

+1 612 354 3923  
[usasupport@resourcedm.com](mailto:usasupport@resourcedm.com)

### RDM Asia

Sky Park at One City  
Jalan USJ 25/1  
47650 Subang Jaya  
Selangor  
Malaysia

+60 3 5022 3188  
[asiatech@resourcedm.com](mailto:asiatech@resourcedm.com)



Visit [www.resourcedm.com/support](http://www.resourcedm.com/support) for more information on RDM solutions, additional product documentation and software downloads.

While every effort is made to ensure the information given within this document is accurate, Resource Data Management Ltd shall not be liable for errors or omissions, for incidental or consequential damages, directly or indirectly, in connection with the furnishing, performance or misuse of this product or document. All specifications are subject to change without notice.

See [www.resourcedm.com](http://www.resourcedm.com) for terms and conditions of sales.

Copyright © Resource Data Management