



**Mercury**  
**PR0711-SUB**



**Intuitive**  
**PR0751-SUB**

# Mercury 2 & Intuitive Mercury Sub Cooler Controller Installation & User Guide



Resource Data Management Ltd  
 80 Johnstone Avenue, Hillington Industrial Estate,  
 Glasgow, Scotland G52 4NZ UK  
 ☎ +44(0)141 810 2828      Switchboard  
 ✉ [support@resourcedm.com](mailto:support@resourcedm.com)      Technical Support  
 ✉ [sales@resourcedm.com](mailto:sales@resourcedm.com)      Sales Enquiries



**Table of Contents:**

**THE MERCURY & INTUITIVE RANGE ..... 4**

**Variants..... 4**

**Configuration ..... 4**

**6-5E as Remote case controller MT (Type 4) ..... 4**

**Compatible Network Interfaces ..... 4**

**Front Display Features ..... 5**

**Connections ..... 5**

**Mercury Mk2 6-5E ..... 5**

**Intuitive Mercury Controller      Intuitive Mercury Network Expansion Options ..... 6**

    Input / Output allocation tables for 6-5E (Electronic Expansion Valve) ..... 6

    Switched Resistor Values ..... 6

**Setting up the controller ..... 7**

    Setup through front buttons ..... 7

    Setup Function Menu (Common to all types)..... 7

**Recommended set-up method ..... 7**

    rtc. Real time clock (This will automatically synchronise on network systems) ..... 7

    type. Set/view controller type ..... 7

    PArA. Set/view parameters (This can be achieved at the network front end) ..... 7

    Unit. Set/view temperature unit and Probe type ..... 8

    Display..... 8

**Parameter Tables ..... 8**

**Parameter Descriptions ..... 10**

**EEV Control Using Pressure ..... 12**

**Maximum Operating Pressure (MOP) ..... 12**

**Relay State and functional operation ..... 12**

**Relay and screen states during defrost ..... 13**

    Defrost Termination..... 13

    Fan Delay after Defrost..... 13

**Network Configuration ..... 13**

    IP Futura module / Intuitive Internal IP Network card ..... 13

**Mercury Switch ..... 14**

**Viewing ..... 14**

    Input / Output Table ..... 14

**Alarm Messages ..... 15**

**Nertork Alarms ..... 15**

**Modifying controller states..... 16**

    Fans Only “FAnS” ..... 16

    Case Off “CASE” ..... 16

    Lights Only “LitS” ..... 16

    Probe Offset..... 16

**Remote Commands ..... 16**

    Power requirements ..... 17

    General..... 17

    Relay Specification..... 17

**Specification ..... 17**

    Inputs..... 18

**Switched Resistor Example Wiring ..... 18**

**Installation ..... 18**

**Dimensions ..... 18**

    Fixing..... 18

**Dimensions ..... 19**

    Intuitive Mercury Mounting Instructions ..... 19

    Cleaning ..... 19

**Disclaimer..... 19**

**APPENDIX 1 DEFROST CYCLES ..... 20**



Ensure that all power is switched off before installing or maintaining this product

APPENDIX 2 TRIM HEATER CONTROL VIA MERCURY/INTUITIVE RANGE.....21

REVISION.....21



Ensure that all power is switched off before installing or maintaining this product

## The Mercury & Intuitive Range From Resource Data Management

The Mercury Mk2 Sub Cooler controller is primarily intended for use in refrigeration display cabinets. It will switch the EEV based on the value of its temperature probe inputs. It has outputs to control lights, fans, suction valve, trim heaters and defrost control. The controller has many features some of which are energy saving; such as the “pulse trim heaters” parameter.

There is also a DIN rail mounted range, known as the Intuitive Mercury range, which is designed to be used in a control panel or electrical tray. This range has the same features as the Mercury Mk2 controller with additional benefits such as higher rated relays each protected by an integral fuse and fuse protection for the incoming power supply, all connections are plug in socket. There are multiple network interfaces to choose from including Ethernet.

Relay 1 is a solid state relay for switching EEVs

The controller supports PT1000, NTC2K, 470R, 700R, 3K, 5K, 6K, NTC2K25, NTC10K temperature probes (note: probe types cannot be mixed)

### Variants

There is only one type used in this controller (Type 4)

Mercury Mk2 6-5E	Electronic expansion valve type with IP protocol (PR0711-SUB)
Intuitive Mercury 6-5E	Electronic expansion valve type with IP protocol (PR0751-SUB)

### Configuration

The controllers are delivered pre-configured:-

6-5E as Remote case controller MT (Type 4)  
**Note:** Type should not be changed.

### Compatible Network Interfaces

Mercury and Intuitive Mercury controllers are capable of connecting to either a TCP/IP local area network, or they can be used in standalone mode with no network output. To connect to a network you must add the correct communications module. Connecting to any of these communication modules will automatically be detected on power up and will affect the set up screens available to you.

Description	Part Number
IP Futura (Single Mercury to IP Interface)	PR0016
Mercury IP Switch (IP support for 10 controllers)	PR0018
Mercury IP Switch with Pressure/Humidity Inputs	PR0018-PHI

The Intuitive Mercury Controller is supplied as standard with an internal RS232 network card, this allows connection to any of the above external network interfaces. There is an alternative internal network card available, this can be supplied factory fitted as an option or purchased separately as an interface kit.

Description	Part Number
Intuitive Internal IP Network Card Interface Kit	PR0770



Ensure that all power is switched off before installing or maintaining this product

## Front Display Features

LED's: -

EEV (Relay 1)



Fans (Relay 2)



Lights (Relay 3)



Defrost (Relay 5)



On-Line



Off:  
Flashing:  
Steady:

No network attached  
Attempting to Log on to network  
On-line

Service



Alarm



HACCP



## Keys



Enter



Up



Down



Defrost

## Main Display



4 character LED display, used to display temperature and status messages.

**Note** the Intuitive Mercury display is Green in colour when lit.

## Connections

### Mercury Mk2 6-5E

Input and Output connections are made to the back of the controller, the RS232 communication port is on the side. The diagram shows the connection detail. Inputs and outputs are assigned according to the chosen configuration. See [Input/Output](#) tables for further details on connections.

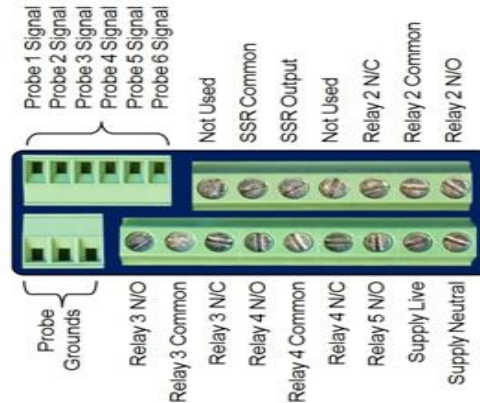

Ensure that all power is switched off before installing or maintaining this product

## Intuitive Mercury Controller

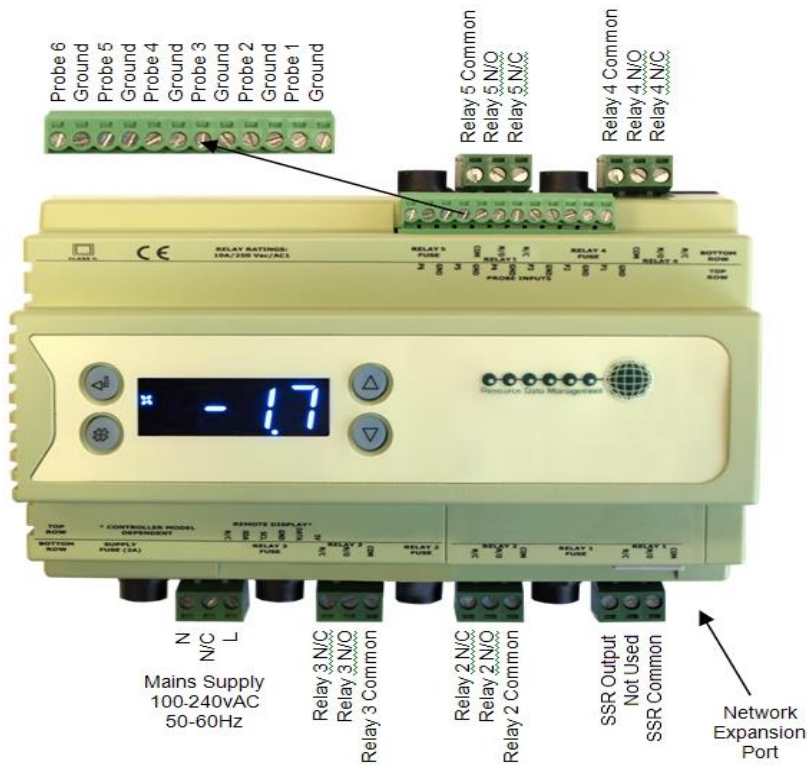

## Intuitive Mercury Network Expansion Options

### RS232 Network Card (Default)

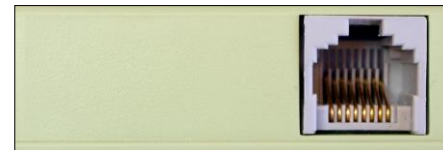

The Intuitive Mercury is supplied with an RS232 Network Card fitted as standard. Some example optional network cards are shown below

### IP Network Card (PR0770)



Rotary Address Switches  
Network Collision LED  
Network Activity LED

All inputs and outputs are plug and socket. The supply voltage and relay outputs have individual fuse protection.

## Input / Output allocation tables for 6-5E (Electronic Expansion Valve)

TYPE	Remote Case Types 4	Alarm Action	Plant Input (Switched Resistors)
Input 1	Air on Temperature	Yes	Plant fault
Input 2	Air off Temperature	Yes	Case Clean Switch
Input 3	Evaporator Temperature	Yes	
Input 4	Suction Line Temperature	Yes	
Input 5	Defrost Termination or Monitor probe (if used)	Conditional*	
Input 6	Logging Probe (If fitted)	Conditional*	
Relay 1	Electronic Expansion Valve	N/A	
Relay 2	Fans	N/A	
Relay 3	Lights/Alarm Relay	N/A	
Relay 4	Suction Line Valve/Trim Heater/Alarm Relay/Remote Relay	N/A	
Relay 5	Defrost Heater (N/O)	N/A	

\* Alarm on monitor probe only if used

### Switched Resistor Values

For PT1000 probes use 820 Ohm switched resistors. The resistors used must have a tolerance of 1% or better and the resistor must have a power rating of 0.25W. For improved accuracy whilst using switched resistors RDM recommend resistors with 0.1% accuracy are used. Note the switched resistor features will **not** function when using 470R or 700R probes. When a resistor is switched across the appropriate input it signals to the Mercury to enable the switched resistor function described for that input whilst still recording the probe temperature on the input.



Ensure that all power is switched off before installing or maintaining this product

## Setting up the controller

Access to the controller can be achieved several ways

- Through the front mounted buttons
- Direct access by PC or palm top into the rear comms port. This requires a software package available on the RDM website
- Through legacy front end panels on 485 networks
- Through the RDM Data Manager.
- Across an IP network. (Current controller IP address required)

### Setup through front buttons



To enter setup mode, hold the Enter and Down buttons together for approximately 3 seconds until the message "Ent" appears on the display. Now press the Enter button again to enter the function menu. IO will be displayed. Scroll up or down to go through the list.

### Setup Function Menu (Common to all types)

Display	Option	Explained in Paragraph	Display	Option	Explained in Paragraph
IO	View Inputs / Outputs and States	<a href="#">Input / output table</a>	nEt	Set/view network configuration	<a href="#">Network Configuration</a>
PArA	Set/View Parameters	<a href="#">Set view parameters</a>	SoFt	View software version	
Unit	Probe type and Celsius/Fahrenheit option	<a href="#">Set View Unit</a>	FANs	Toggle Fans Only mode	<a href="#">Fans</a>
diSP	Display whole units or decimal	<a href="#">Display</a>	CASE	Toggle Case Off mode	<a href="#">Case Off</a>
tyPE	Set/View Controller Type	<a href="#">Set/view controller type</a>	Lits	Toggle Lights Only mode	<a href="#">Lights</a>
rtc	Set/view Clock (rtc = Real Time Clock)	<a href="#">Real Time Clock</a>	OFSt	Probe Offset	<a href="#">Probe Offset</a>
			ESC	Exit Setup mode	

### Recommended set-up method

If you are not connecting to a network and want to set up the controller through the buttons we recommend you use the following order from the function menu.

#### rtc. Real time clock (This will automatically synchronise on network systems)

- Use the up or down buttons to scroll through the display until the display reads "rtc"
- Press enter. The display will show "t-1". press enter again
- Scroll hours up or down (0 – 23) press enter
- Use up button to select "t-2", press enter
- Scroll minutes up or down (0 – 59) press enter
- Repeat for t-3 (seconds 0 – 59)
- Repeat for t-4 (Days up to 31)
- Repeat for t-5 (months up to 12)
- Repeat for t-6 (Year up to 99)
- Use up button to display "ESC", press enter to display "rtc"

Time clock is now set

#### type. Set/view controller type

- From the function menu scroll to select type, press enter
- Use the up/down buttons to scroll through case/coldroom configuration types. (see [configuration table on](#) page 4)
- Press enter.
- Scroll to select "ESC"
- Press enter

Controller type configuration is now set

#### PArA. Set/view parameters (This can be achieved at the network front end)

- From the function menu scroll to select PArA
- Pressing Enter while PArA is displayed will enter the parameter menu. The first parameter option will be displayed as P-01. Pressing the Up or Down button will present the other parameter options P-02, P-03 etc. See the parameter list below to find what parameter number corresponds to which actual parameter. Pressing the Enter button will show the current value of the selected parameter. Press Up or Down to modify the value and press Enter again to save the value. The parameter list number will be displayed again. Two other options are present in the parameter menu – dFLt and ESC. Selecting ESC will exit setup mode. Selecting dFLt will reset all parameters back to the default values for the current type of controller.



Ensure that all power is switched off before installing or maintaining this product

## Unit. Set/view temperature unit and Probe type

From the function menu scroll to select Unit  
Press enter and the value will be displayed: -

### Probe Types

- |                         |                           |
|-------------------------|---------------------------|
| 0 for PT1000 Celsius    | 10 for NTC2K25 Celsius    |
| 1 for PT1000 Fahrenheit | 11 for NTC2K25 Fahrenheit |
| 2 for NTC2K Celsius     | 12 for 5K Celsius         |
| 3 for NTC2K Fahrenheit  | 13 for 5K Fahrenheit      |
| 4 for 470R Celsius      | 14 for 6K Celsius         |
| 5 for 470R Fahrenheit   | 15 for 6K Fahrenheit      |
| 6 for 700R Celsius      | 16 for NTC10K Celsius     |
| 7 for 700R Fahrenheit   | 17 for NTC10K Fahrenheit  |
| 8 for 3K Celsius        |                           |
| 9 for 3K Fahrenheit     |                           |

Use the up or down keys to select the units and press enter.

**This function is now complete**

### Display

From the function menu scroll to and select diSP.

Press enter and one of the following values will be shown: -

- 0. Controller display will show the whole number and tenths value of a temperature reading. (Default)
- 1. Controller display will show temperatures as a whole number.

### Parameter Tables

Number	Parameter	Range °C (°F)	Step	Units	Default HT °C (°F)
P-01	Cut-in Temp.	-42 to 30 (-43.6 to 86)	0.1	Deg	0.0 (32)
P-02	Diff.	0 to 10 (0 to 18)	0.1	Deg	1.5 (2.7)
P-03	Control Weight	0 to 100	1	%	50
P-04	Display Weight	0 to 100	1	%	50
P-08	Superheat Ref	0 to 12 (7.2 to 21.6)	0.1	Deg	6 (10.8)
P-09	Response On	1 to 30	1		10
P-10	Response Off	1 to 30	1		10
P-11	Control Type	0 = EEV 1 = EET 2 = EEV/EET	1		0
P-51	EEV Minimum Opening	0 - 100%	1	%	10
P-52	Superheat Problem	0 - 12 °C (0 - 21.6 °F)	0.1	Deg	0
P-53	Superheat EEV Problem Opening	0 - 100%	1		10
P-54	Superheat EEV Problem Time	00:00 to 99:00	01:00	mm:ss	03:00
P-56	EEV Start Opening	0 - 100%	1	%	10
P-55	Average Valve Opening	0 - 100%	1	%	100
P-57	Scaling Factor	0 - 100%	1		50
P-12	Relay 4 Mode	0 = Suction Line 1 = Trim Heater 2 = Alarm 3 = Remote	1		0
P-13	Trim in Defrost	0 (Off), 1(On)			0
P-14	Trim Level	0 to 100	1	%	100
P-85	Key-switch Mode	0 = Case Off 1 = Fans only 2 = toggle	1		0
P-87	Control Probe type	0 = Use Air on Probe 1 = Use Log Probe	1		0
P-90	Resistor Case Off	0 (Disabled), 1(Enabled)			0
P-92	Fans temperature mode	0 = Off 1 = Temperature 2 = Over-temperature 3 = Temp/OT	1		0



Ensure that all power is switched off before installing or maintaining this product

P-93	Fans Off Temperature	-42 to 30 (-43.6 to 86)	0.1	Deg	8 (46.4)
P-15	Probe 5 Select	0 = Defrost, 1 = Monitor	1		0
P-16	Relay 3 Mode	0 = Lights, 1 = Alarm	1		0
P-17	Suction Select	0 = Local 1 = Remote	1		0
P-97	Control Fail Valve Level (EEV)	0 to 100%	0.1	%	0
P-20	Alarm Delay	00:00 to 99:00	01:00	mm:ss	20:00
P-21	UT Alarm	-49 to 60 (-56.2 to 140)	0.1	Deg	-2 (28.4)
P-22	OT Alarm	-49 to 60 (-56.2 to 140)	0.1	Deg	5 (41)
P-23	Log Probe Type	0 (Off), 1 (Logging), 2 (Logging/Alarm)			Off
P-24	Slug Log Probe	0 (Off), 1 (On)			Off
P-25	Log Alarm Delay	00:00 to 99:00	01:00	mm:ss	20:00
P-26	Log UT Alarm	-49 to 60 (-56.2 to 140)	0.1	Deg	-1 (30.2)
P-27	Log OT Alarm	-49 to 60 (-56.2 to 140)	0.1	Deg	6 (42.8)
P-28	Monitor OT Alarm	-49 to 60 (-56.2 to 140)	0.1	Deg	20 (68)
P-40	Defrost Mode	0 (Local), 1 (Remote), 2 (External)			Local
P-41	Defrost Start	00:00 to 23:59	00:01	hh:mm	01:00
P-42	Defrosts per Day	0 to 8	1		6
P-43	No Defrost Time	0 to 25	1	hours	12
P-44	Def Terminate Temp.	-42 to 30 (-43.6 to 86)	0.1	Deg	10 (50)
P-45	Def Min Time	00:00 to 99:00	01:00	mm:ss	05:00
P-46	Def Max Time	00:00 to 99:00	01:00	mm:ss	24:00
P-47	Drain Down	00:00 to 24:00	00:15	mm:ss	01:30
P-48	Recovery Time	00:00 to 99:00	01:00	mm:ss	30:00
P-89	Pump Down Time	00:00 to 99:00	01:00	mm:ss	00:00
P-86	Fan Delay mode	0 = Time 1 = Temp	1		0
P-49	Fan Delay Time	00:00 to 99:00	01:00	mm:ss	00:00
P-88	Fan Delay Temp	-42 to 30 (-43.6 to 86)	0.1	Deg	0.0 (32)
P-50	Fans In Defrost	0 (Off), 1 (On)			On
P-94	Defrost Hold	0 (Off), 1 (On)			Off
P-95	Defrost Skip	0 (Off), 1 (On)			Off
P-96	Defrost Skip Time	00:00 to 99:00	01:00	mm:ss	12:00
P-60	Lights Mode	0 (Local), 1 (Remote), 2 (Man Off), 3 (Man On)			Local
P-61	Sun Lights On	00:00 to 23:59	00:01	hh:mm	08:00
P-62	Sun Lights Off	00:00 to 23:59	00:01	hh:mm	20:00
P-63	Mon Lights On	00:00 to 23:59	00:01	hh:mm	08:00
P-64	Mon Lights Off	00:00 to 23:59	00:01	hh:mm	20:00
P-65	Tue Lights On	00:00 to 23:59	00:01	hh:mm	08:00
P-66	Tue Lights Off	00:00 to 23:59	00:01	hh:mm	20:00
P-67	Wed Lights On	00:00 to 23:59	00:01	hh:mm	08:00
P-68	Wed Lights Off	00:00 to 23:59	00:01	hh:mm	20:00
P-69	Thu Lights On	00:00 to 23:59	00:01	hh:mm	08:00
P-70	Thu Lights Off	00:00 to 23:59	00:01	hh:mm	20:00
P-71	Fri Lights On	00:00 to 23:59	00:01	hh:mm	08:00
P-72	Fri Lights Off	00:00 to 23:59	00:01	hh:mm	20:00
P-73	Sat Lights On	00:00 to 23:59	00:01	hh:mm	08:00
P-74	Sat Lights Off	00:00 to 23:59	00:01	hh:mm	20:00
dFLt	Restore defaults				



Ensure that all power is switched off before installing or maintaining this product

## Parameter Descriptions

Number	Parameter	Description
P-01	Cut-in Temp	Temperature at which the EEV will start to open.
P-02	Diff	Differential temperature below the cut-in temperature. The EEV switches off when below this temperature
P-03	Control Weight	Percentage of the Air-On temperature that is used to calculate the control temp. The remaining percentage will be used on the Air-Off temperature Example, P-03 set to 30% Control temp = 30% Air-on + 70% Air-off
P-04	Display Weight	As above only applied to the display temperature
P-08	Superheat Ref	The controller will attempt to maintain this superheat value
P-09	Response on	Allows the user to speed up the EEV on time. With 30 providing the quickest response and 1 providing the slowest response.
P-10	Response off	Allows the user to speed up the EEV off time. With 30 providing the quickest response and 1 providing the slowest response.
P-11	Control Type	Allows the user to select either EEV control, EET control or EEV/EET control. <b>Note</b> the Evaporator Temperature probe should be fitted to the coldest point in the evaporator. EEV uses the superheat as its main reference with the cabinet temperature as a secondary control. EET use the cabinet temperature as its main reference. EEV/EET uses cabinet temperature as the main control until the SH gets close to the SH reference point, then it switches to EEV control, it switches back to EET control when the SH reference is satisfied.
P-51	EEV Minimum Opening	Sets the minimum valve opening level, during normal operation the valve will not go below this level. (Default 10%) IF used in conjunction with a Mercury Pressure Hub PR0018-PHI then the Minimum value should be set at <b>0%</b>
P-52	Superheat Problem	Sets the point at which the algorithm will go to the "EEV Problem" state due to the superheat temperature. For example if this parameter is set to 0 Degrees and the Superheat value falls to 0 degrees or below, for the duration of P-54, then the controller will enter the superheat problem state.
P-53	Superheat EEV Problem Opening	Sets the valve open position when entering the "Superheat EEV Problem" state.
P-54	Superheat EEV Problem Time	Sets the time the algorithm stays in the "Superheat EEV Problem" state.
P-56	EEV Start Opening	Sets the valve opening % which is used after a defrost or when the controller exits a problem state for, example Superheat EEV Problem state
P-55	Average Valve Opening	Normally the valve during recovery will open to the last average position. This setting allows for that value to be reduced by said percentage. For example if the average valve opening is calculated as 80% and P-55 is set to 50% then the valve will open at 40%.
P-57	Scaling Factor	This parameter only takes effect when the controller is used in conjunction with a Mercury Switch pressure application. When the Mercury Switch generates the MOP alarm the controller reduces the maximum valve opening to this percentage. For example if this parameter is set to 50% and the MOP alarm is generated then the maximum valve opening will be limited to 50%. Therefore as the controller pulses the valve the maximum the valve will open is 50%. Note P-51 EEV Minimum opening overrides the valve output operation and the valve will not pulse below this setting.  Please see <a href="#">MOP</a> note.  <b>Please note</b> parameters P-51 through to P-57 should not be altered without first understanding the effects they may have on the case operation. If incorrectly set they may have undesired affects.
P-12	Relay 4 Mode	Relay 4 can be a Suction, Trim Heater, Alarm, Remote or Trim Hub relay. <ul style="list-style-type: none"> <li>➤ Suction – set for Suction Line Valve operation.</li> <li>➤ Trim Heater – set as trim relay which pulses in accordance with P-14 or the Data Manager energy feature trim control.</li> <li>➤ Alarm – The alarm relay is energised for no alarm. Use the NC and Common for "Loop make" on alarm or use the NO and Common for "Loop break" on alarm.</li> <li>➤ Remote – The relay is available for remote purposes such as the Data Manager GP timer channel or Data Builder software.</li> </ul>
P-13	Trim in Defrost	Allows the trims to be off or on during a defrost.
P-14	Trim Level	Sets a percentage level, of a 5-minute period, to pulse the trim heater relay off/on. Example: - P-14 set to 50% = 2.5 minutes on, 2.5 minutes off. If the controller is networked to a Data Manager operating the energy feature Trim Control then the Data Manager feature will override this parameter setting. Please refer to the Data Manager user document for further details. <b>Note</b> the trims are turned off when an over temperature alarm occurs.
P-85	Key-switch Mode	Allows the keys switch to be: - <ul style="list-style-type: none"> <li>➤ Single turn for case off (Case off mode)</li> <li>➤ Single turn for Fans only (Fans Mode)</li> <li>➤ Single turn for case off, double turn for fans only (Toggle mode)</li> </ul>
P-87	Control Probe type	Switches between using the air-on probe and the Logging probe. Note the control and display temperature will still be a derivative of the weighted Average of the control probe + Air-off probe



Ensure that all power is switched off before installing or maintaining this product

P-90	Resistor Case Off	Turns on/off the switched resistor case off function
P-92	Fans temperature mode	Allows the user to set the fans to turn off when: - <ul style="list-style-type: none"> <li>➤ A pre-determined temperature is reached (P93)</li> <li>➤ When an over-temperature alarm is present</li> <li>➤ When either P93 is reached or an OT alarm is present</li> </ul>
P-93	Fans Off Temperature	Temperature for the above (P92) operation. <b>Note</b> the defrost termination probe is the source of the temperature reading used in this feature. If the defrost termination probe isn't fitted then a similar process to P-44 is used.
P-15	Probe 5 Select	This input can be used as a defrost termination probe (default) or as a monitor probe with an OT alarm level (P-28)
P-16	Relay 3 mode	This changes the function of relay 3 from Lights (default) to an alarm relay. The alarm relay is energised for no alarm. Use the NC and Common for "Loop make" on alarm or use the NO and Common for "Loop break" on alarm.
P-17	Suction Select	This allows the control algorithm to use a remote temperature input in place of the evaporator in value. In the event of no remote value being received, the control algorithm will revert to using the evaporator in probe value until the remote value is restored. Please see <a href="#">EEV Control Using Pressure</a> .
P-97	Control Fail Valve Value	This value is used in the event of a control probe fail; In the EEV control algorithm the valve will remain at this opening until the probe fault has been cleared. <b>Please note</b> the incorrect setting of this value may result in flood back causing damage to the pack compressors. Do not adjust this parameter if you are unsure of the consequences.
P-20	Alarm Delay	Delay for the over and under-temperature alarms
P-21	UT Alarm	Under temperature alarm set point. This alarm uses the control temperature.
P-22	OT Alarm	Over temperature alarm set point. This alarm uses the air-off temperature.
P-23	Log Probe Type	Allows the user to set the logging probe mode: - <ul style="list-style-type: none"> <li>➤ Off</li> <li>➤ Logging with no alarms</li> <li>➤ Logging with alarms</li> </ul>
P-24	Slug Log Probe	Applies a damping factor. This can be used to make a standard probe have the same temperature response as a logging probe.
P-25	Log Alarm Delay	Delay for the Logging probe over and under-temperature alarms
P-26	Log UT Alarm	Logging probe under temperature alarm set point
P-27	Log OT Alarm	Logging probe over temperature alarm set point
P-28	Monitor OT Alarm	Monitor probe over temperature alarm set point
P-40	Defrost Mode	Allows the user to set the defrost mode: - <ul style="list-style-type: none"> <li>➤ Local (Uses the internal parameters P-41 and P-42)</li> <li>➤ Remote (Requires a defrost schedule in the front end)</li> </ul>
P-41	Defrost Start	When defrost mode is set to "Local", this is the start time for the 1 <sup>st</sup> defrost
P-42	Defrosts per Day	When defrost mode is set to "Local", this is the number of defrosts per day equally spaced from the start time.
P-43	No Defrost Time	If the controller misses a defrost command for any reason, a defrost will initiate after this time has elapsed from the last defrost. Normally set to 2 hours over the normal defrost period.
P-44	Def Terminate	The defrost will terminate (defrost control relay off) when the temperature of the defrost termination probe reaches this value.  If the "defrost termination" probe is not fitted, defrost termination will occur when: - The "coil in" probe reaches the set point (If fans are selected as "off during defrost") Or The "air off" probe reaches the set point (If fans are selected as "on during defrost"). If the "coil in" probe is not fitted, the "air off" probe will be used.
P-45	Def Min Time	Minimum time that a defrost will use (Defrost can't terminate until this time has elapsed. If termination temperature is reached during this period, the defrost control relay is turned off, but the controller will not continue the defrost cycle until the end of the defrost min period)
P-46	Def Max Time	Time period after defrost minimum that defrosts are allowed to terminate
P-47	Drain Down	A period after defrost max to allow the draining of any surplus water
P-48	Recovery Time	The EEV opens at the start of this period to allow the temperature to recover to the normal operating point. This period also inhibits the OT alarm. Note that if the air-off temperature is still above the OT alarm setpoint when this period expires, an immediate OT alarm occurs; there is <b>not</b> a further alarm delay.
P-89	Pump Down Time	Time period before the defrost min period to allow for a pump down
P-86	Fan Delay mode	This parameter allows the fans start after a drain-down period to be delayed, either by time (P-49) or when the temperature point (P-88) is reached. This parameter uses the same probe strategy as the defrost terminate.
P-49	Fan Delay	Time after a drain-down period before the fans start if P-86 is set to time
P-88	Fan Delay Temp	Temperature at which the fans start after a drain-down period when P-86 is set to temperature.
P-50	Fans In Defrost	Allows the user to set the fans on or off in defrost. Note if the fans are set to on in defrost, they will go off for the drain-down period and then follow the P-86 rules.
P-94	Defrost Hold	Turns the defrost hold feature on and off. When switched on, the controller can be held in defrost until a remote command from the front end starts the recovery process.



Ensure that all power is switched off before installing or maintaining this product

P-95	Defrost Skip	Allows user to enable/disable defrost skip. This feature allows the controller to skip defrosts. If the current defrost terminates on temperature then the controller will skip the next scheduled defrost providing the previous defrost terminated before the defrost skip time (P-96). Operates only when the controller is set to local defrost scheduling.
P-96	Defrost Skip Time	Time factor used in defrost skip. The previous defrost has to terminate before this value expires to allow the controller to skip a defrost.
P-60	Lights Mode	Allows the user to set the lights mode: - <ul style="list-style-type: none"> <li>➤ Always off</li> <li>➤ Always on</li> <li>➤ Use a local schedule P-61 to P-74)</li> <li>➤ Use a remote schedule (Set up in the system front end)</li> </ul>
P-61	Sun Lights On	When P-60 is set to Local, Sunday on time
P-62	Sun Lights Off	When P-60 is set to Local, Sunday off time
P-63	Mon Lights On	When P-60 is set to Local, Monday on time
P-64	Mon Lights Off	When P-60 is set to Local, Monday off time
P-65	Tue Lights On	When P-60 is set to Local, Tuesday on time
P-66	Tue Lights Off	When P-60 is set to Local, Tuesday off time
P-67	Wed Lights On	When P-60 is set to Local, Wednesday on time
P-68	Wed Lights Off	When P-60 is set to Local, Wednesday off time
P-69	Thu Lights On	When P-60 is set to Local, Thursday on time
P-70	Thu Lights Off	When P-60 is set to Local, Thursday off time
P-71	Fri Lights On	When P-60 is set to Local, Friday on time
P-72	Fri Lights Off	When P-60 is set to Local, Friday off time
P-73	Sat Lights On	When P-60 is set to Local, Saturday on time
P-74	Sat Lights Off	When P-60 is set to Local, Saturday off time
dFLt	Restore default values	Restores all of the parameters to their default values

### EEV Control Using Pressure

The Mercury Switch (PR0018-PHI) can be used for EEV control on an Island by island basis. In an EEV application the evaporator in temperature probe reading for a case controller can be obtained from the Mercury switch on which the controller is connected. A suction pressure transducer is connected from the case Island to the 4-20mA input of the Mercury Switch and the pressure read from this transducer is converted to a temperature based on the gas type being used by the system. This temperature is transmitted to each controller connected to the switch and along with the suction temperature probe local to the controller the superheat is calculated. Please note that RDM recommended that the evaporator in temperature probe is fitted as the controller will use this to calculate the superheat in the event of a communication loss with the Mercury Switch. P-17 allows for the use of this remote temperature provided by the Mercury Switch. Please see the Mercury Switch user document (PR0018-PHI) for further details.

### Maximum Operating Pressure (MOP)

Maximum Operating Pressure (MOP) support added to Mercury E and M. MOP is a remote command sent from the Mercury switch (PR0018-PHI) to the controller to either close or reduce the EEV valve opening when a predetermined pressure is reached. This MOP value is configured in the Mercury switch setup. When the Mercury Switch generates the MOP alarm the controller reduces the maximum valve opening to this percentage. For example if the "Div Value" parameter is set to 50% and the MOP alarm is generated then the maximum valve opening will be limited to 50%. Therefore as the controller pulses the valve the maximum the valve will open to is 50%.

### Relay State and functional operation

Relay 1-3 State	Function State	Wired contact
Relay 1 off	EEV Closed	SSR Output
Relay 1 on	EEV Open	SSR Output
Relay 2 off	Fans on	N/C
Relay 2 on	Fans off	N/C
Relay 3 off	Lights on	N/C
Relay 3 on	Lights off	N/C
Relay 3 off	Alarm Relay = Alarm	N/C
Relay 3 on	Alarm Relay = OK	N/C

Relay 4-5 State	Function State	Wired contact
Relay 4 off	Suction or Trims off	N/O
Relay 4 on	Suction or Trims on	N/O
Relay 4 off	Alarm Relay = Alarm	N/C
Relay 4 on	Alarm Relay = OK	N/C
Relay 5 off	Defrost control off	N/O
Relay 5 on	Defrost control on	N/O



Ensure that all power is switched off before installing or maintaining this product

## Relay and screen states during defrost

State:	Pump Down	Defrost Min	Defrost Max	Drain Down	Fan Delay	Recovery
Screen:	DEF	DEF	DEF	DEF	DEF	REC
Def LED:	On	On	On	Off	Off	Off
RLY 1 EEV	Closed	Closed	Closed	Closed	Open	Open
RLY 4 Suction Line	On	On	On	On	Off	Off
RLY 4 Trim on in defrost	On	On	On	On	On	On
RLY 4 Trim off in defrost	Off	Off	Off	Off	Off	On
RLY 5 Defrost Relay	Off	On	On	Off	Off	Off
RLY 3 Lights relay	On	On	On	On	On	On
RLY 2 Fans (On in DF)	On	On	On	On	Off	On
RLY 2 Fans (Off in DF)	Off	Off	Off	Off	Off	On

## Defrost Termination

Defrost termination will be when the temperature parameter "def terminate" has been reached on the "defrost termination" probe. If the "defrost termination" probe is not fitted, defrost termination will occur when: -

- Or The "coil in" probe reaches the set point (If fans are selected as "off during defrost")
- Or The "air off" probe reaches the set point (If fans are selected as "on during defrost")

If the "coil in" probe is not fitted, the "air off" probe will be used. If the "air off" probe is faulty termination will occur when the time-out period has elapsed.

## Fan Delay after Defrost

The fans will come back on when: -

- Or The fan delay time has elapsed if the "fan delay mode" is set to time
- Or If the fan delay mode is set to "temp", the fans will come on when the defrost termination probe reaches the fan delay set point, or on the time parameter, whichever occurs first.

If the "defrost termination" probe is not fitted, the fans will come on when: -

- Or The "coil in" probe reaches the control set point (If fans are selected as "off during defrost")
- Or The "air off" probe reaches the control set point (If fans are selected as "on during defrost")

## Network Configuration

The final section to setup is the network address. In all instances, this must be done before the controller is plugged into the site network. The controllers have an auto-initialise function, which will automatically log the device onto the site network. If the wrong address has been entered onto the network, you will have to reset the controller address by setting the address to 00-0, and then re-enter the correct address. (You may have to deregister the wrong address from the home system as well).

When logging a Mercury or Intuitive Mercury with an RS232 interface onto a network you must first connect the controller to a communications module, this is either an IP Futura or Mercury Switch. When using an Intuitive Mercury controller, the controller has to have the correct network card fitted (see "compatible network interfaces"). For connection to a Mercury Switch (Hub) or an external network interface, the standard fitment RS232 network card is utilized.

## IP Futura module / Intuitive Internal IP Network card

In an IP system there are two options,

- IP-L
- IP-r

IP-L allows you to fix an IP address into the controller, which you would use when you are connecting the controllers onto a customer's local area network. This would allow the customer to view each controller using Internet Explorer

IP-r allows you to give each controller on the system a unique number. This number is then allocated a dynamic IP address by the system DHCP server (such as the RDM Data Manager or Data Director)

## IP-L

To configure the communication module or network card for IP-L, set all three rotary switches to zero. The module should then be connected to the controller. In the case of an Intuitive Mercury controller where the network card is already fitted, the controller should be powered off, all three rotary switches set to zero and the controller powered on.

1. nEt. From the function menu you can now select nEt
  - Press enter and the display will show "IP-L", press enter
  - You can now set the address using the table below



Ensure that all power is switched off before installing or maintaining this product

Display	Option
IP-1	IP Address byte 1
IP-2	IP Address byte 2
IP-3	IP Address byte 3
IP-4	IP Address byte 4
nL	Network Mask Length
gt-1	Gateway Address byte 1
gt-2	Gateway Address byte 2
gt-3	Gateway Address byte 3
gt-4	Gateway Address byte 4
ESC	Exit network menu. <b>N.B.</b> this option <b>must</b> be selected to save any changes made in this menu

## IP-r

To configure the communication module for IP-r, set the three rotary switches to give each controller a unique identifier. The module should then be connected to the controller and the network. In the case of an Intuitive Mercury controller where the network card is already fitted, the three rotary switches must be set when the controller is powered off, the controller should then be powered on to connect to the network.

2. nEt. From the function menu you can now select nEt
  - Press enter and the display will show "IP-r", press enter
  - You can now view only the address given by the DHCP server

To ease setup, a single network mask length value is used. If the address has been specified with a network mask value in dotted IP format e.g. 255.255.255.0 then the table below gives the conversion:

Mask	Length	Mask	Length	Mask	Length
		255.255.254.0	23	255.254.0.0	15
255.255.255.252	30	255.255.252.0	22	255.252.0.0	14
255.255.255.248	29	255.255.248.0	21	255.248.0.0	13
255.255.255.240	28	255.255.240.0	20	255.240.0.0	12
255.255.255.224	27	255.255.224.0	19	255.224.0.0	11
255.255.255.192	26	255.255.192.0	18	255.192.0.0	10
255.255.255.128	25	255.255.128.0	17	255.128.0.0	09
255.255.255.0	24	255.255.0.0	16	255.0.0.0	08

## Mercury Switch

Please refer to the Mercury Switch user guide, which can be obtained from the RDM website, for information regarding connecting a controller to a network.

## Viewing

Apart from setting up the controller, you can also view the status of the inputs and outputs and controller states. From the function menu, select "I/O", press enter. You can now scroll through the IO table as set out below. Inputs and outputs that do not apply to a particular controller type will be greyed out.

## Input / Output Table

Number	IO	Range* °C ( °F )	Step	Units
I-01	Control Temp.	-42 to 60 (-43.6 to 140)	0.1	Deg
I-02	Display temp	-42 to 60 (-43.6 to 140)	0.1	Deg
I-03	Air on Probe	-49 to 60 (-56.2 to 140)	0.1	Deg
I-04	Air off Probe	-49 to 60 (-56.2 to 140)	0.1	Deg
I-05	Evaporator Probe	-42 to 60 (-43.6 to 140)	0.1	Deg
I-06	Suction Line Probe	-42 to 60 (-43.6 to 140)	0.1	Deg
I-07	Superheat	-30 to 60 (-54 to 108)	0.1	Deg
I-08	Logging Probe	-49 to 60 (-56.2 to 140)	0.1	Deg
I-09	Defrost Probe	-49 to 60 (-56.2 to 140)	0.1	Deg
I-10	Plant Fault	0 (OK), 1 (Alarm)		
I-11	Case Clean	0 (Off), 1 (On)		
I-15	Monitor Probe	-49 to 60 (-56.2 to 140)	0.1	Deg
I-16	Remote Evaporator Temp	-49 to 60 (-56.2 to 140)	0.1	Deg
O-05	Defrost Control	0 (Off), 1 (On)		



Ensure that all power is switched off before installing or maintaining this product

O-06	Lights	0 (Off), 1 (On)		
O-07	Case Fans	0 (Off), 1 (On)		
O-09	EEV Opening	0 to 100	0.1	%
O-10	Last Def. Time	00:00 to 23:59		hh:mm
O-11	Last Def. Length	00:00 to 03:00		hh:mm
O-12	Last Def. Ctrl Temp.	-42 to 60 (-43.6 to 140)	0.1	Deg
O-13	Last Def. Type	0 (None), 1 (Internal), 2 (External), 3 (Network), 4 (Display), 5 (Timed)		
O-14	Suction Line Valve/Trim Heaters	0 (Open/Off), 1 (Closed/On)		
O-15	Alarm Relay (Relay3)	0 (Unused), 1 (OK), 2 (Alarm)		
O-16	Alarm Relay (Relay4)	0 (Unused), 1 (OK), 2 (Alarm)		
O-17	Remote Relay (Relay 4)	0 (Off), 1 (On)		
O-18	Scaling Factor	0 to 100	0.1	%
O-30	Set Point Offset	-49 to 60 (-56.2 to 140)	0.1	Deg.
O-31	Trim Off Period	00:00 to 05:00	00:01	mm:ss
S-01	Control State	0 (Stabilise), 1 (Normal), 2 (Defrost Min), 3 (Defrost Max), 4 (Drain Down), 5 (Fan Delay), 6 (Recovery), 7 (OT Alarm), 8 (UT Alarm), 9 (Fans Only), 10 (Lights Only), 11 (Case Off), 12 (Pump Down), 13 (Defrost Hold)		
S-02	Valve State	0 (Off), 1 (Start), 2 (Run), 3 (Problem), 4 (Fail)		

## Alarm Messages

The following alarms and messages can appear on the Mercury display.

Display Message	System status
Ft	Control Fault
Prb1	Probe 1 Fault
Prb2	Probe 2 Fault
Prb3	Probe 3 Fault
Prb4	Probe 4 Fault
Prb5	Probe 5 Fault
Prb6	Probe 6 Fault
rEC	Control State in Recovery
dEF	Control Sate in Defrost
AL	Control State in Alarm
FANs ONLY	Controller in Fans Only
LitS ONLY	Controller in Lights Only
CASE OFF	Controller in Case Off
Ot	Over Temperature Alarm
Ut	Under Temperature Alarm
PLnt	Plant Fault
LgOt	Log Probe Over Temperature
LgUt	Log Probe Under Temperature

## Nertork Alarms

The table below shows the text and associated type number that is sent to the system "front end". The type number is normally used to provide different alarm actions.

Alarm text	Type # (index)
Missed defrost	15
Plant Fault	3
Case over temperature	4
Case under temperature	5
Probe 1,2,3,4,5 or 6 Faulty	6
Product over temperature	8
Product under temperature	9
Monitor Probe OT	12
Case Off	29



Ensure that all power is switched off before installing or maintaining this product

## Modifying controller states

During normal operation you can change the following states from the function menu

### Fans Only "FAnS"

Selecting the Fans Only option will put the controller into the Fans Only state if the current state is not Fans Only. If the current state is Fans Only then the controller will change to the Normal state. Selecting this option will exit the setup menu automatically. The display will show "FAnS OnLy"

If a remote display with key switch is being used, this function can be invoked by turning the key switch to the fans only position (90 degrees clockwise) with parameter P85 set to "fans"

### Case Off "CASE"

Selecting the Case Off option will put the controller into the Case Off state if the current state is not Case Off. If the current state is Case Off then the controller will change to the Normal state. Selecting this option will exit the setup menu automatically. The display will show "CASE OFF". An alarm is generated, fixed delay of 1 minute, when the controller is placed into the Case Off state.

If a remote display with key switch is being used, this function can be invoked by turning the key switch to the case-off position. (Clockwise 90 degrees) with parameter P85 set to "case".

### Lights Only "LitS"

Selecting the Lights Only option will put the controller into the Lights Only state if the current state is not Lights Only. If the current state is Lights Only then the controller will change to the Normal state. Selecting this option will exit the setup menu automatically. The display will show "LitS OnLy"

Note. When lights are being used in "Remote" mode with a timing channel: -

If the controller goes offline, the lights are turned ON after a delay of 5 minutes. The lights will stay on until the controller comes back on-line where they will revert to the state of the timing channel being used.

### Probe Offset

This feature allows each probe value to be modified by an "offset". Offset values are from -10°C (-18°F) to +10°C (+18°F) and on a channel basis. Example C1 = Probe 1.

### Remote Commands

The following commands can be used by a Data Builder program: -

Command	Value to send	Description	Conditions
Defrost Command	1	Initiates a defrost cycle	Defrost mode: remote
Defrost Command	3	Terminates the defrost	Defrost mode: remote Defrost hold: On Defrost min state complete
Trim Command	0 to 100%	Sets the trim level to this value (Trim period is 5 minutes)	Relay 4 mode: Trim Heater
Setpoint Command	±20°C (±34°F)	Is added to or subtracted from the setpoint	
Case Off Command	5 0	Sets the controller to Case Off Restores the controller from Case Off to Normal	
Haccp Command	0 1 2	HACCP LED OFF HACCP LED On HACCP LED Flashes	
Button Command	0 1 2	Buttons backlights Off Buttons backlights On Buttons Backlights Flash	
EEV Command	2 1	Shuts the valve off Restores the valve to normal operation	
Divider Command	0 to 100%	Sets the maximum valve opening to this percentage.	

Use an "Analogue Out" block configured to the controller name and in the value field type in the command you require. Use a "Setting block" as the input to the "Analogue Out" block to send the Value.

See Example on the right, which sets the Trim Heater on BY10-1 at 40%

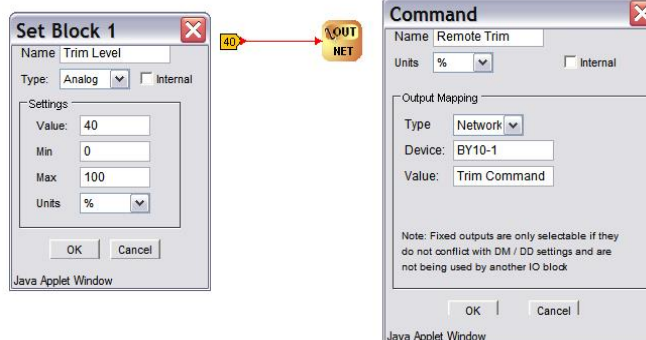

Ensure that all power is switched off before installing or maintaining this product

## Specification

	Mercury Mk2 Controller PR0711-SUB	Intuitive Mercury controller PR0751-SUB
<b>Power requirements</b>		
<b>Supply Voltage Range</b>	100 - 240 Vac $\pm 10\%$	100 - 240 Vac $\pm 10\%$
<b>Supply Frequency</b>	50 - 60 Hz	50 - 60 Hz
<b>Maximum supply current</b>	5.2 Amps (when relay 5 is fully loaded)	2 Amps
<b>Typical supply current</b>	<1 Amp	<1 Amp
<b>General</b>		
<b>Operating temperature range</b>	+5°C to +50°C	-10°C to +60°C
<b>Storage temperature range</b>	-20°C to +65°C	-20°C to +65°C
<b>Environmental</b>	Indoor use at altitudes up to 2000m, pollution degree 1, installation category II. Voltage fluctuations not to exceed $\pm 10\%$ of nominal voltage.	Indoor use at altitudes up to 2000m, pollution degree 1, installation category II. Voltage fluctuations not to exceed $\pm 10\%$ of nominal voltage.
<b>Size</b>	78mm (W) x 36mm (H) x 110mm (D)	157mm (W) x 67mm (H) x 120 (D)
<b>Approx Weight</b>	170 grams	500 grams
<b>Safety</b>	EN61010	EN61010
<b>EMC</b>	EN61326; 1997 +Amdt. A1; 1998	EN61326; 1997 +Amdt. A1; 1998
<b>Ventilation</b>	There is no requirement for forced cooling ventilation	There is no requirement for forced cooling ventilation
<b>Class 2 Insulation</b>	<b>No</b> protective Earth is required and <b>none</b> should be fitted	<b>No</b> protective Earth is required and <b>none</b> should be fitted
<b>Supply Fuse</b>	The host equipment must provide a suitable external over-current protection device such as: - Fuse: 6.3A 240 Vac Antisurge (T) HRC conforming to IEC 60127	Built in fuse holder, fuse 2A 240Vac Antisurge (T) HRC conforming to IEC60127, 32 x 6.3mm
<b>Or MCB</b>	6A, 240 VAC Type C conforming to BS EN 60898	2A, 240 VAC Type C conforming to BS EN 60898 (Note: controller has integral 2A fuse)
<b>Relay Fuse</b>	Not Fitted	10A 240Vac Antisurge (T) HRC conforming to IEC60127, 32 x 6.3mm
<b>Relay Specification</b>		
	<b>Relay 1 Solid State Exclusive common</b>	<b>Relay 1 Solid State Exclusive common</b>
<b>Max current</b>	1.5A	1.5A
<b>Max voltage</b>	280Vac	280Vac
	<b>Relays 2-4 Mechanical Exclusive common</b>	<b>Relays 2- 5 Mechanical Exclusive common</b>
<b>Max current</b>	6A Resistive (Cos $\phi$ = 1) 2A Inductive ( Cos $\phi$ = 04)	.10A Resistive (Cos $\phi$ = 1) 3A Inductive ( Cos $\phi$ = 04)
<b>Max voltage</b>	250Vac, 30V dc	250Vac, 30V dc
<b>Relay Fuse</b>	N/A	10A 240Vac Antisurge (T) HRC conforming to IEC60127, 32 x 6.3mm
		All relays are independent and can operate at different potentials to the supply voltage
	<b>Relay 5 Mechanical Common connected to supply live</b>	
<b>Max current</b>	3A (non inductive), COS $\phi$ =0.4 2A (inductive load) 200,000 operations	
<b>Max voltage</b>	250Vac (Internal supply)	
	For compliance with the LVD, relays 3, 4 and 5 commons must be at the same potential as the supply voltage	



**Warning: On Mercury Mk2 Controllers Relay 5 output has hazardous voltages (Supply input voltage potential)**  
This does not apply to the Intuitive Mercury controller



Ensure that all power is switched off before installing or maintaining this product

**Inputs**

Input resistance: 3.01K Ohms (for PTC or NTC type probes)  
 Input type: PT1000 or NTC2K or NTC2K25 or NTC10K (selectable)

Comms: RS232 with flow control

**Switched Resistor Example Wiring**

Example of resistor fitted on a probe input. Connect to remote switch or relay

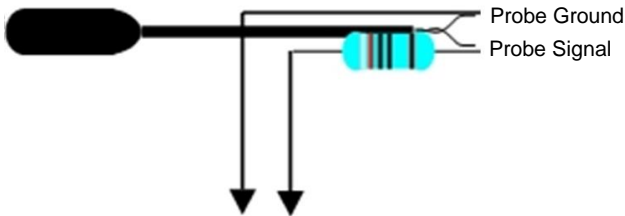

**Installation**

**Panel Cut-out and Clearances**

**Mercury Mk2 (Flush mount controller)**

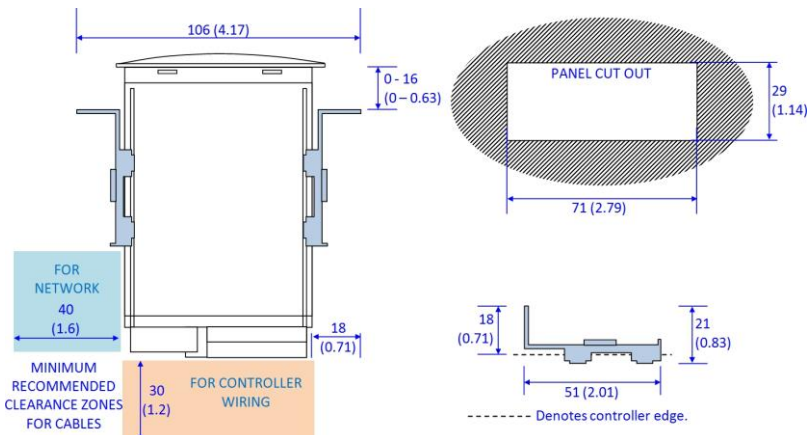

**Fixing**

The controller is fixed by sliding the 2 plastic retaining clips up to rear of the panel. These clips have a ratchet action and can be removed by holding in the clip sides and sliding back.

There is no requirement for forced cooling ventilation

**Dimensions**

**Mercury Mk2**

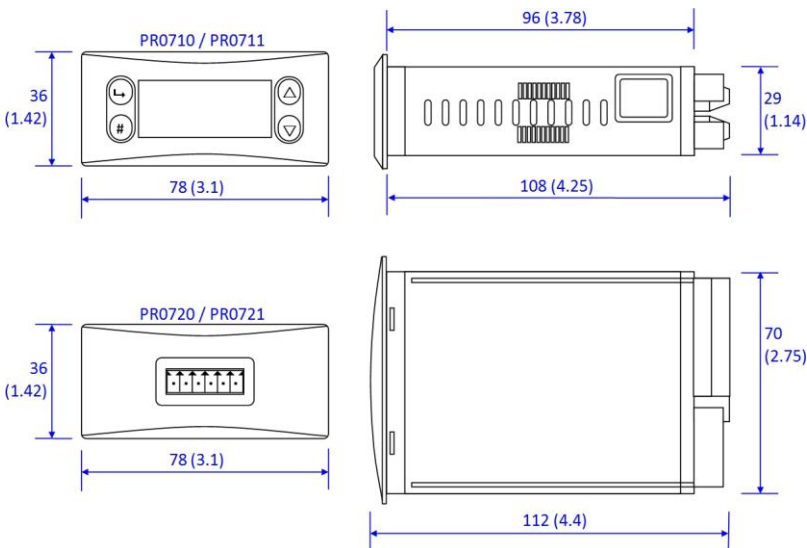

Ensure that all power is switched off before installing or maintaining this product

**Dimensions**

**Intuitive Mercury controller**

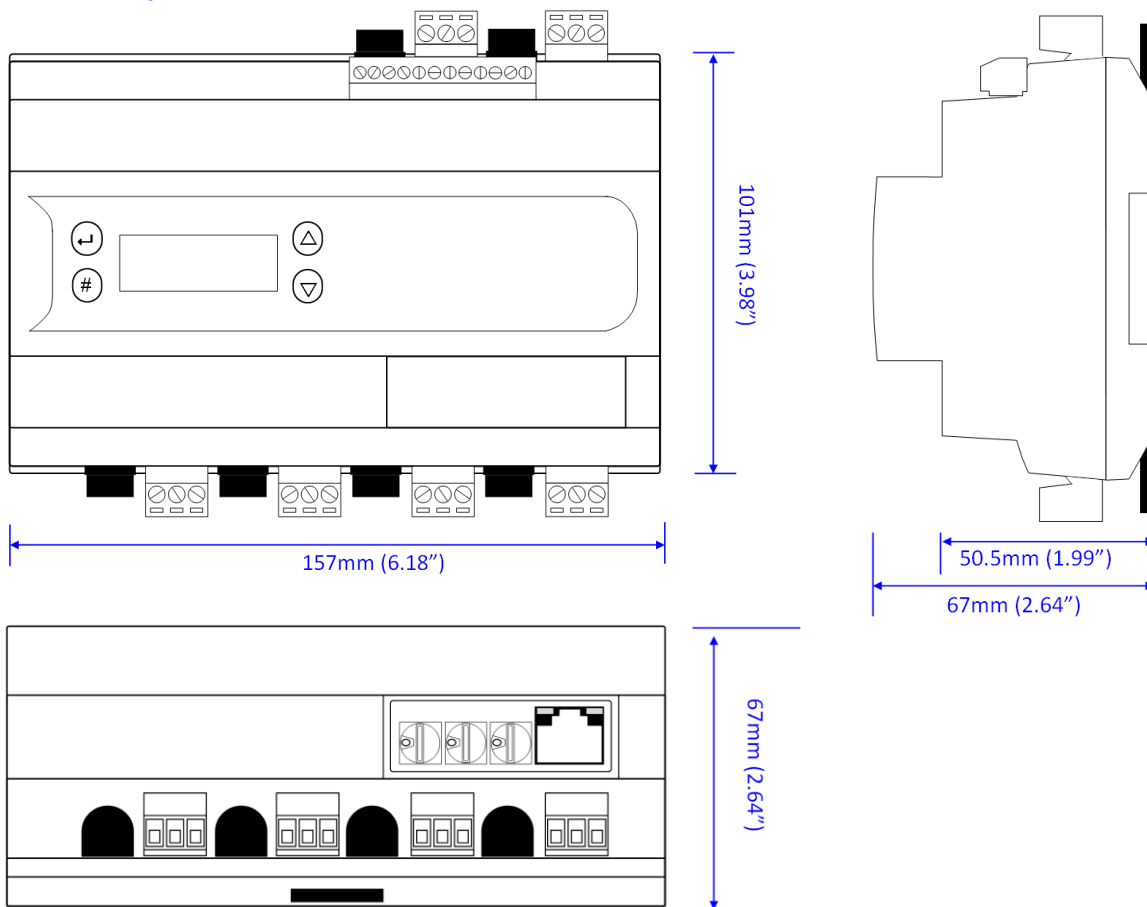

**Intuitive Mercury Mounting Instructions**

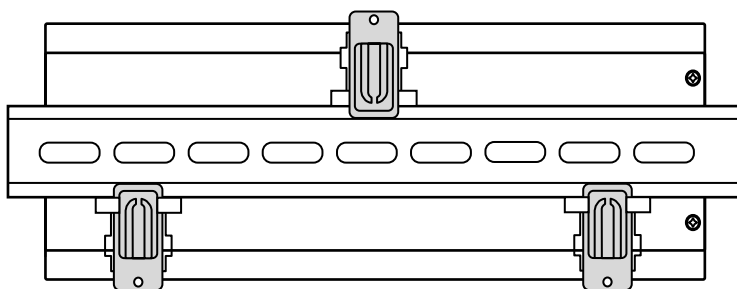

Three clips fix the Intuitive Mercury securely to DIN rail. Pull each clip until it “clicks” to remove the controller. Each clip has a mounting hole to provide an alternative fixing mechanism to DIN mounting.

**Cleaning**

Do not wet the controller when cleaning. Clean the front by wiping with slightly dampened lint free cloth.

**Disclaimer**

The specifications of the product detailed in this document may change without notice. RDM Ltd shall not be liable for errors or omissions, for incidental or consequential damages, directly or indirectly, in connection with the furnishing, performance or misuse of this product or document.

## Appendix 1 Defrost Cycles

### Fans On in Defrost

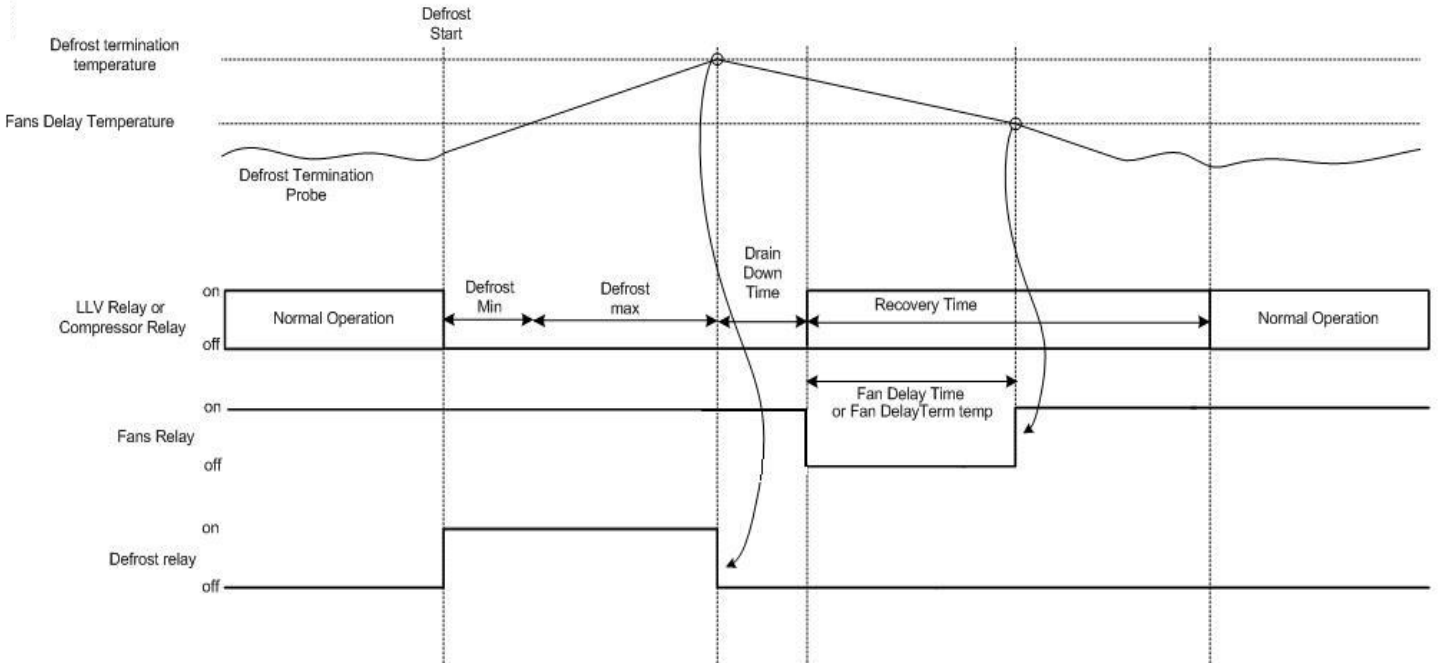

### Fans Off in Defrost

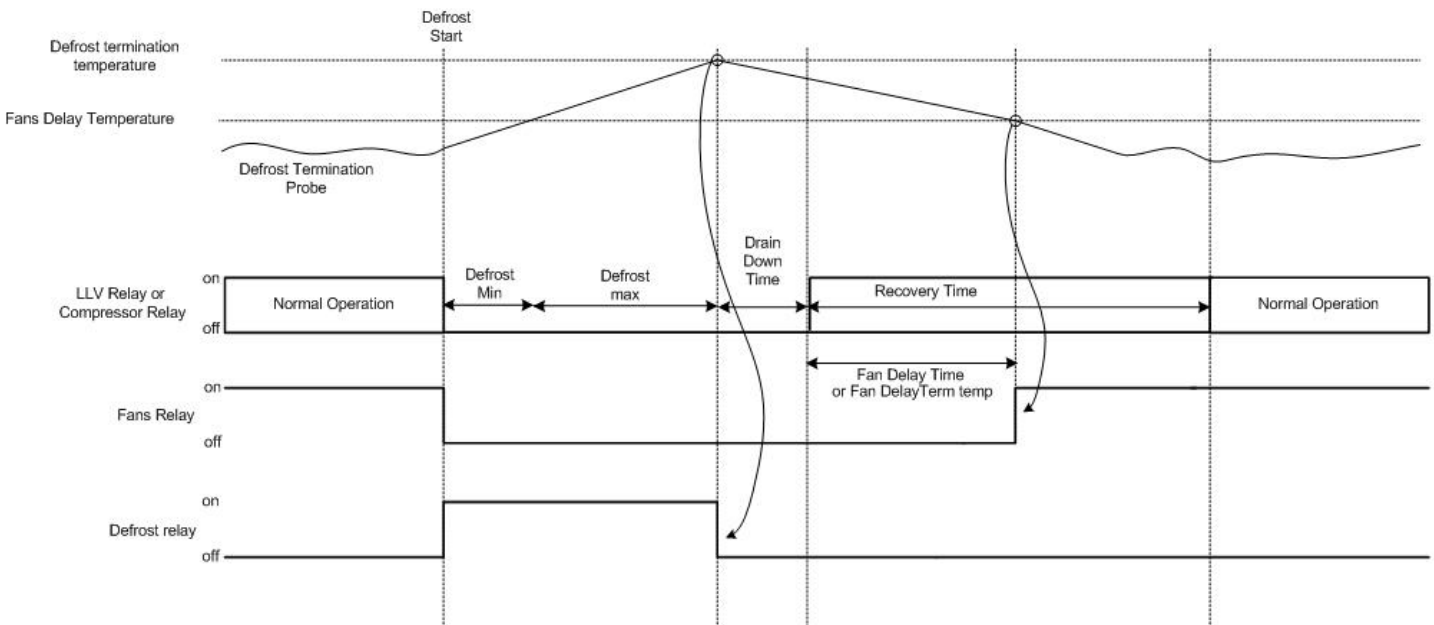

## Appendix 2 Trim Heater Control via Mercury/Intuitive Range

Energy savings via the RDM's range of case controllers can be achieved in a number of ways. One of which is pulsing the trim heater relay off for a given period of time. One way to pulse the trim heater is by configuring P-14. For greater energy savings the Data Manager energy feature trim control or the Mercury Switch trim control feature can be used. These two options pulse the trim relay dependant on the actual shop floor humidity levels. Thus if the shop floor humidity is relatively low the trim heaters can be pulsed off for longer durations. Please see the relevant user guides for further details.

RDM recommend that the Trim Heater Pulse Module (PR0723) is used in all instances of trim control. This module is fitted in between the trim heater of the case and the relay output of the Controller which is pulsing the heater. The trim heater module output provides a smoother power distribution, compared to using the relay output directly, as it switches at the zero voltage crossover point. Switching the trim heater on and off via a normal relay, without using the RDM trim heater pulse module, may damage the trim heater and reduce the operational life of the heater. Therefore RDM recommend the use of this module in every trim heater control application. Please see the Trim Heater Pulse Module user guide for further details.

### Revision

Revision	Date	Changes
1.0	04/07/2011	Current Release
1.0A	13/08/2012	Parameter description amended
1.0b	06/01/2015	Operating temperature range updated



Ensure that all power is switched off before installing or maintaining this product