



Resource
Data Management

Mercury & Intuitive Mercury Controller

Installation & User Guide
Software Revisions 5.3M & 5.5E



PR0740 CAS PR075X / PR076X

Contents

| | |
|--|----|
| The Mercury & Intuitive Mercury Range..... | 4 |
| Hardware Variants | 4 |
| Current Software Versions | 4 |
| Compatible Displays | 4 |
| Configuration | 4 |
| Compatible Network Interfaces | 5 |
| Front Display Features Mercury Display..... | 6 |
| Mercury I/O Connections (PR0740) | 7 |
| Intuitive Mercury I/O Connections | 8 |
| Intuitive Mercury Network Expansion Options..... | 8 |
| Input and Output Allocation Tables | 9 |
| M-type (Mechanical Expansion Valve or Compressor) | 9 |
| E-type (PWM Electronic Expansion Valve) | 10 |
| Switched Resistor Values | 10 |
| Transducer Input – Electronic Expansion Valve type only | 11 |
| Ordering Information | 11 |
| Mercury Hardware | 11 |
| Intuitive Mercury Hardware..... | 11 |
| Setting up the controller..... | 12 |
| Setup through front buttons..... | 12 |
| Setup Function Menu (Common to all types) | 12 |
| Recommended set-up method..... | 13 |
| rtc. Real time clock (This will automatically if networked to a DM Touch or Mini DM) | 13 |
| | 13 |
| type. Set/view controller type | 13 |
| PArA. Set/view parameters (This can be achieved at the network front end) | 13 |
| Unit. Set/view temperature unit and Probe type | 13 |
| PrES. Set Pressure Units..... | 14 |
| diSP. Display selection | 14 |
| dtyP. Set / view display type..... | 14 |
| Parameter Tables | 14 |
| Parameter Descriptions | 19 |
| Load Shedding | 25 |
| Superheat Options..... | 25 |
| EEV Control Using Pressure..... | 26 |
| Mercury Switch (PR0018-PHI) or Intuitive Switch (PR0757/758)..... | 26 |
| Remote pressure from a networked RDM Pack Controller | 26 |
| Local Analogue Input – mA or V | 26 |
| Maximum Operating Pressure (MOP) | 26 |
| Ref Weighting | 26 |
| Valve Control Type | 26 |
| Relay State and functional operation..... | 27 |
| Relay and screen states during defrost..... | 28 |
| Defrost Type (P-91) | 28 |
| Defrost Termination | 28 |
| Fan Delay after Defrost | 28 |
| Network Configuration | 28 |
| Mercury RS232 Variant & Intuitive Mercury | 28 |
| RS485 module/ Intuitive Internal RS485 Network card | 30 |
| Mercury IP Variant..... | 30 |
| Viewing IO..... | 31 |
| Input / Output Table | 31 |
| Maximum and Minimum Control Temperature | 32 |
| Display Messages | 33 |
| Network Alarms..... | 33 |



| | |
|--|----|
| Modifying controller states | 33 |
| Fans Only "FanS" | 33 |
| Case Off "CASE" | 33 |
| Lights Only "Ligt" | 34 |
| Probe Offset..... | 34 |
| Remote Commands | 35 |
| Specification | 36 |
| Switched Resistor Example Wiring | 37 |
| Installation& Dimensions | 37 |
| Panel Cut-out and Clearances..... | 37 |
| Fixing..... | 37 |
| Dimensions – Mercury | 38 |
| Dimensions – Intuitive Mercury Controller | 38 |
| Intuitive Mercury Mounting Instructions..... | 39 |
| Cleaning | 39 |
| Appendix 1: Defrost Cycles | 39 |
| Appendix 2: Trim Heater Control via Mercury/ Intuitive Range | 41 |
| Appendix 3: Webpage Appearance | 41 |
| Disclaimer | 52 |
| Revision History | 53 |



The Mercury & Intuitive Mercury Range

From Resource Data Management

The Mercury & Intuitive Mercury controllers are primarily intended for use in refrigeration display cabinets or coldroom applications. It will switch the evaporator valve (LLV or PWM EEV) based on the value of its temperature or pressure input. It has outputs to control lights, fans, suction valve, trim heaters and defrost control. It can have variable inputs for reading a pressure transducer along with two digital inputs. A further four digital inputs can be added by utilising the switched resistors feature.

The controller has many features, some of which are energy saving, such as pulsed trim heaters or the case off with lights parameter (see parameter section for further details). There are several hardware variants of the Mercury & Intuitive Mercury controllers split into two types; an **E-version** that has Relay 1 as a **Solid State Relay** for switching PWM EEVs and the second is an **M-version** that has Relay 1 as an **electro-mechanical relay** for switching solenoid LLVs or compressor. For these two types, there are further options of adding analogue inputs, choice of serial or built in IP communications along with either a remote or integral display option (see ordering PR0740).

The controller supports PT1000, NTC2K, 470R, 700R, 3K, 5K, 6K, NTC2K25, NTC10K or NTC10K (Type2)

Hardware Variants

As mentioned above, the Mercury and Intuitive Mercury controllers offer a number of choices concerning the physical hardware including choice of IO, Display and communications type. Depending on the valve type (electronic expansion or mechanical solenoid valve) the option of either a solid state or mechanical relay is available. For specific part numbers see [Ordering Information](#).

| Inputs/ Outputs | Relay 1 | Display | Comms |
|--|-------------------|--------------------------|------------------|
| 6 Probe, 2 Digital Inputs / 5 Relay Outputs | Mechanical Relay | Integral/ Remote Display | Serial/ Ethernet |
| 6 Probe, 2 Digital & 2 Analogue Inputs / 5 Relay Outputs | Solid State Relay | | |

Current Software Versions

| Variant | Version |
|---|---------|
| E-type (PWM Electronic Expansion Valve) | 5.5 |
| M-type (Mechanical Expansion Valve or Compressor) | 5.3 |

Compatible Displays

The following displays are compatible with the Mercury / Intuitive Mercury Remote Display Controllers:

| Description | Part Number |
|---|-------------|
| Mercury DIN Remote Display with 5m cable | PR0327 |
| Mercury DIN Key switch Remote Display with 5m cable | PR0328 |
| Mercury Remote Display with 5m cable | PR0725 |
| Mercury Remote Display with 1.5m cable | PR0725A |
| Mercury Coldroom Display with 1.5m cable | PR0152 |

Configuration

The controller gives you up to six configuration options (see '[Type](#)' menu):

| Display value | Mercury / Intuitive Mechanical Expansion Valve | Mercury / Intuitive PWM Electronic Expansion Valve |
|---------------|--|--|
| 1 | Integral controller (HT) | N/A |
| 2 | Integral controller (LT) | N/A |
| 3 | Remote piped case controller (LT) | Remote piped case controller (LT) |
| 4 | Remote piped case controller (HT) | Remote piped case controller (HT) |
| 5 | Coldroom controller (LT) | Coldroom controller (LT) |
| 6 | Coldroom controller (HT) | Coldroom controller (HT) |

Note: The controllers are delivered pre-configured as **Type 1** and **Type 3** for variants **M** and **E** respectively.



Compatible Network Interfaces

Mercury and Intuitive Mercury controllers which do not have an IP interface built in are capable of connecting to either a TCP/IP local area network, an RS485 Genus compatible network or they can be used in standalone mode with no network output. To connect to a network you must add the correct communications module. Connecting to any of these communication modules will automatically be detected on power up and will affect the 'Net' menu set up screens available to you. **Note** controllers with built in IP will be able to communicate to any IP switch, including the rear ports of the RDM Mercury Hub.

| Description | Part Number |
|---|--------------------|
| IP Futura (Single Mercury to IP Interface) | PR0016 |
| IP Futura, DIN rail mounted | PR0016-DIN |
| IP Futura, DIN rail mounted with 2 x CAT 5 sockets | PR0016-DUALDIN |
| Intuitive Switch with 6 x RS232 ports, 4 x Ethernet Ports and a 4-20mA Pressure Transducer connection. | PR0758-6P4E-PHI |
| Intuitive Switch with 12 x RS232 ports and 4 x Ethernet Ports | PR0758-12P4E |
| Intuitive Switch with 12 x RS232 ports, 4 x Ethernet Ports and a 4-20mA Pressure Transducer connection. | PR0758-12P4E-PHI |
| Intuitive Switch with 16 x RS232 ports, 4 x Ethernet Ports and a 4-20mA Pressure Transducer connection. | PR0758-16P4E-PHI |
| Intuitive Switch with 16 x RS232 ports, 3 x Ethernet Ports and 1 x Fibre connection. | PR0757-16P3E-F |
| Intuitive Switch with 16 x RS232 ports, 3 x Ethernet Ports, 1 x Fibre connection and a 4-20mA Pressure Transducer connection. | PR0757-16P3E-F-PHI |
| Bluetooth RS232 Network Module | PR0630 |



Front Display Features

LEDs:

Valve (Relay 1) 

Fans (Relay 2) 

Lights (Relay 3) 

Defrost (Relay 5) 

On-Line Status 

- Off: No network attached
- Flashing: Attempting to Log on to network
- Steady: On-line

Service (See P-18) 

Alarm 

HACCP 

Mercury Display



Keys



Enter



Up



Down



Defrost

Defrost: Press and hold the defrost button to force a manual defrost

Main Display

4 character LED display, used to display temperature and status messages.



Mercury I/O Connections (PR0740)

Input and Output connections are made to the back of the controller, the RS232/ Ethernet communication port is on the side. The diagram below shows the connection detail. Inputs and outputs are assigned according to the chosen configuration. See [Input/output](#) tables for further details on connections. Below also shows you the transducer connections available with the Mercury E variant.

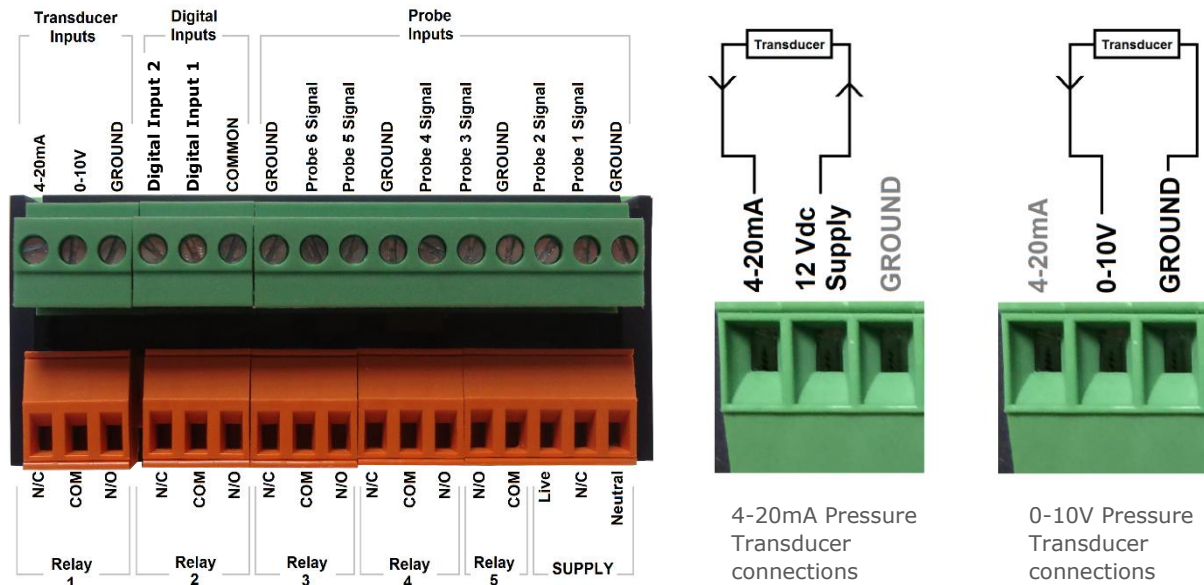

Note: On the supply terminals, N/C equates to 'No Connection'.

Note: On the PR0740 E, relay 1 will be an SSR and valve should be connected to COM and N/C terminals, N/O is not used.

Note: If using a 0-10v pressure transducer, the pressure transducer will require its own power supply. Power is not obtained from the Mercury controller.



Intuitive Mercury I/O Connections

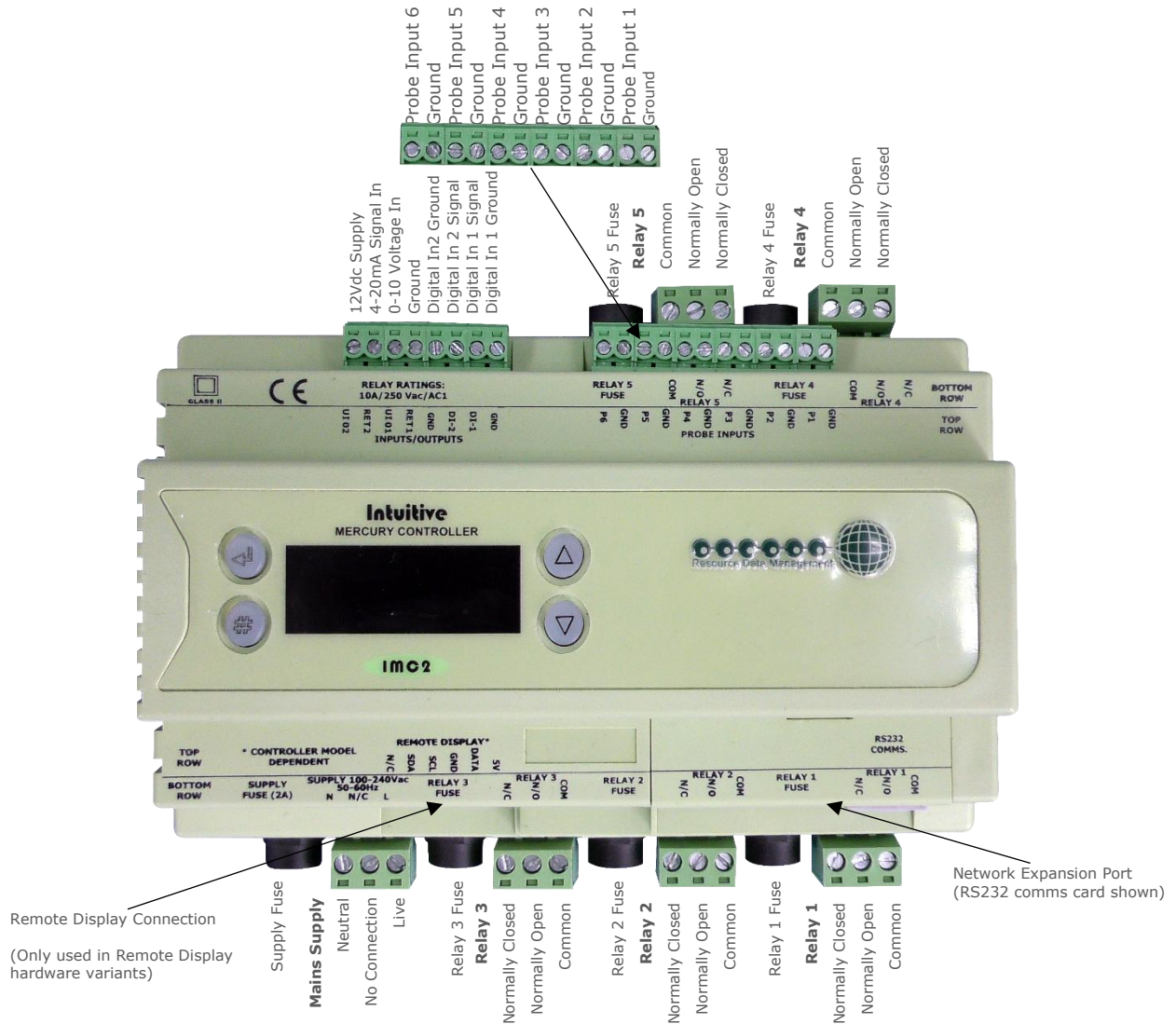

Note: On the PR0751, relay 1 will be an SSR and valve should be connected to COM and N/O terminals as labelled on the Network Card, the X terminal is not used.

Note: If using a 0-10v pressure transducer, the pressure transducer will require its own power supply. Power is not obtained from the Mercury controller.

Intuitive Mercury Network Expansion Options

The Intuitive Mercury is supplied with an RS232 Network Card fitted as standard.

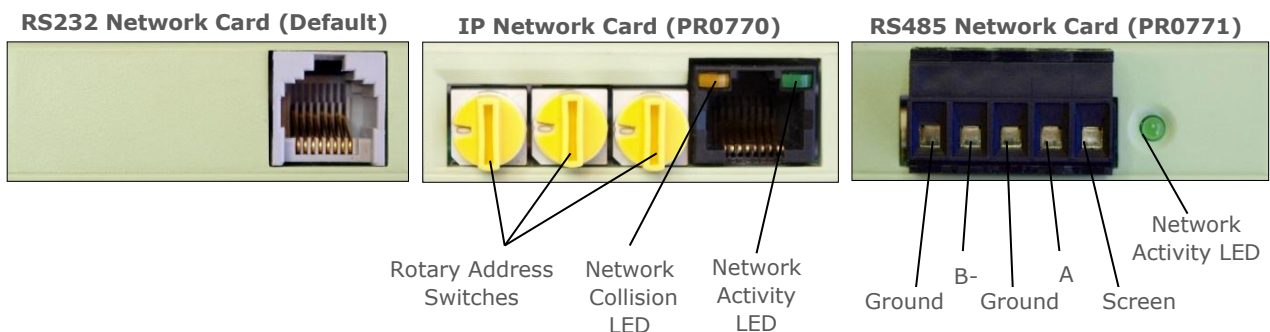

Input and Output Allocation Tables

The following tables indicate; on a controller type basis, the functions of the inputs and outputs. Also shown, are the digital inputs that are derived by switching in a fixed value resistor across the input.

M-type (Mechanical Expansion Valve or Compressor)

| I/O | Integral Case Types 1&2 | Remote Case Types 3&4 | Coldroom Controller Types 5&6 | Alarm Action | Plant Input (Switched Resistors) |
|-----------------|---|---|--|---------------|---|
| Input 1 | Air on Temperature | Air on Temperature | Air on Temperature | Yes | |
| Input 2 | Air off Temperature | Air off Temperature | Air off Temperature | Yes | Person Trap alarm type 5 & 6 |
| Input 3 | Evaporator Temperature | Evaporator Temperature | Evaporator Temperature | No | Plant fault 3 or External Defrost Input |
| Input 4 | Suction Line Temperature | Suction Line Temperature | Suction Line Temperature | No | Case Clean Switch |
| Input 5 | Defrost Termination or Monitor probe (if used) | Defrost Termination or Monitor probe (if used) | Defrost Termination or Monitor probe (if used) | Conditional* | Plant fault 4 on types 1 & 2 Door switch on types 5 & 6 |
| Input 6 | Logging Probe (If fitted) | Logging Probe (If fitted) | Logging Probe (If fitted) | Conditional** | |
| Variable Inputs | Not used | | | N/A | |
| Digital 1 | Selectable; Plant 1 N/O, Plant 1 N/C, Case Switch, Temp Switch, Defrost | Selectable; Plant 1 N/O, Plant 1 N/C, Case Switch, Temp Switch, Defrost | Selectable; Plant 1 N/O, Plant 1 N/C, Case Switch, Temp Switch, Defrost, Door, Person Trap | Conditional | |
| Digital 2 | Selectable; Plant 2 N/O, Plant 2 N/C, Case Switch, Temp Switch, Defrost | Selectable; Plant 2 N/O, Plant 2 N/C, Case Switch, Temp Switch, Defrost | Selectable Plant 2 N/O, Plant 2 N/C, Case Switch, Temp Switch, Defrost, Door, Person Trap | Conditional | |
| Relay 1 | Compressor A | Liquid Line Valve | Liquid Line Valve | N/A | |
| Relay 2 | Fans | Fans | Fans | N/A | |
| Relay 3 | Lights/Alarm Relay | Lights/Alarm Relay (2) | Lights/Alarm Relay | N/A | |
| Relay 4 | Compressor B | Suction Line Valve/Trim Heater/Alarm Relay (1)/Remote Relay | Suction Line Valve/Alarm Relay/Remote | N/A | |
| Relay 5 | Defrost Heater | Defrost Heater (N/O) | Defrost Heater (N/O) | N/A | |

* Probe will alarm if set to monitor probe in parameters.

** Probe will alarm if log probe type is set to 'Logging/Alarm' in parameters



E-type (PWM Electronic Expansion Valve)

| I/O | Remote Case Types 3&4 | Coldroom Controller Types 5&6 | Alarm Action | Plant Input (Switched Resistors) |
|-------------------|---|---|---------------|-----------------------------------|
| Input 1 | Air on Temperature | Air on Temperature | Yes | Plant fault 3 or External Defrost |
| Input 2 | Air off Temperature | Air off Temperature | Yes | Case Clean Switch |
| Input 3 | Evaporator Temperature | Evaporator Temperature | Yes | |
| Input 4 | Suction Line Temperature | Suction Line Temperature | Yes | |
| Input 5 | Defrost Termination or Monitor probe (if used) | Defrost Termination or Monitor probe (if used) | Conditional* | Door Switch on types 5 & 6 |
| Input 6 | Logging Probe (If fitted) | Logging Probe (If fitted) | Conditional** | Person Trap on types 5 & 6 |
| Variable Input mA | Transducer Input (if fitted) | Transducer Input (if fitted) | Yes | |
| Variable Input V | Transducer Input (if fitted) | Transducer Input (if fitted) | Yes | |
| Digital 1 | Selectable; Plant 1 N/O, Plant 1 N/C, Case Switch, Temp Switch, Defrost | Selectable; Plant 1 N/O, Plant 1 N/C, Case Switch, Temp Switch, Defrost, Door Switch, Person Trap | Conditional | |
| Digital 2 | Selectable; Plant 2 N/O, Plant 2 N/C, Case Switch, Temp Switch, Defrost | Selectable; Plant 2 N/O, Plant 2 N/C, Case Switch, Temp Switch, Defrost, Door Switch, Person Trap | Conditional | |
| Relay 1 | Electronic Expansion Valve | Electronic Expansion Valve | N/A | |
| Relay 2 | Fans | Fans | N/A | |
| Relay 3 | Lights/Alarm Relay | Lights/Alarm Relay (2) | N/A | |
| Relay 4 | Suction Line Valve/Trim Heater/Alarm Relay/Remote Relay | Suction Line Valve/Alarm Relay (1) /Remote | N/A | |
| Relay 5 | Defrost Heater (N/O) | Defrost Heater (N/O) | N/A | |

* Probe will alarm if set to monitor probe in parameters.

** Probe will alarm if log probe type is set to 'Logging/Alarm' in parameters

Switched Resistor Values

The switched resistor functionality can be turned on and off within the parameter section (P-19). When switched on, it adds the benefit of adding further digital inputs for switches using fixed resistors. For wiring please see the '[Switched Resistor Wiring](#)' section. When a resistor is switched across the appropriate input, it signals to the Mercury to enable the switched resistor function (described for that input) whilst still recording the probe temperature on the input.

For the function to work, it requires specific resistors depending on the probe type used;

| Probe Type | Resistor |
|--------------------|----------|
| PT1000 | 820Ω |
| NTC2K, NTC2K25, 3K | 590Ω |
| 5K, 6K | 1kΩ |
| NTC10K | 2k7Ω |
| NTC10K(2) | 2k2Ω |

The resistors used must have a tolerance of 1% or better and the resistor must have a power rating of 0.25W. For improved accuracy whilst using switched resistors RDM recommend resistors with 0.1% accuracy are used. **Note:** the switched resistor features will **not** function when using 470R or 700R probes.

The temperature range for all probe types for probe inputs which do not have a secondary function (switched resistors) is -49°C to +128°C. Inputs which have use the secondary (digital) function are restricted to -42°C to +60°C. If the full temperature range is required on all inputs and no switch resistor features are needed then please see Switch Resistor parameter P-19.

Note: switched resistors will operate in LT (Low Temperature) and HT (High Temperature) applications using PT1000, NTC2K or NTC2K25 probe types only. For all other probe types the switched resistor inputs will work in HT applications only.



Transducer Input – Electronic Expansion Valve type only

There are two possible inputs that can be used for a transducer on the Mercury & Intuitive Mercury E hardware variant; either using the 0-10v or the 4-20mA. Please consult the [I/O Connections](#) for wiring. Depending on the type of transducer (0-10v or 4-20mA) the physical input can be chosen using p-17. The parameters on the controller (p-35 & p-36) must then be set so the transducer is read.

Ordering Information

Mercury Hardware

When ordering a Mercury controller the following ordering scheme can be used to purchase the desired hardware configuration.

PR0740- X Y Z CAS

| X | Description |
|---|-------------------|
| M | Mechanical Relay |
| E | Solid State Relay |

| Y | Description |
|---|-------------------------|
| D | Local/ Integral Display |
| R | Remote Display |

| Z | Description |
|-----|----------------|
| IP | Ethernet Comms |
| 232 | RS232 Comms |

Example

To order a Mercury with a Solid state relay (for PWM EEV's), Remote display and IP comms;

PR0740 – E R IP CAS

Intuitive Mercury Hardware

When ordering a Mercury Intuitive controller the following ordering scheme can be used to purchase the desired hardware configuration.

PR07WX YZ

| W | Description | X | Description | Y | Description | Z | Description |
|---|------------------|---|---------------------|-------|-------------|-------|-------------|
| 5 | Internal Display | 0 | Mechanical Relay | Blank | Fused | Blank | RS232 Comms |
| 6 | Remote Display | 1 | SSR Relay (PWM EEV) | NF | Non-Fused | IP | IP Comms |
| | | | | | | 485 | RS485 Comms |

Example:

To order an Intuitive Mercury to control a PWM EEV, non-Fused with a remote display and IP Comms:

PR0761NFIP



Setting up the controller

Access to the controller can be achieved by several ways;

Serial Communications Variant

- Through the front mounted buttons of the display
- Direct access by PC into the serial comms port. This requires a software package available on the RDM website.
- Through the RDM Data Manager.
- Across an IP network (Current controller IP address required).

Ethernet Communications Variant

- Through the front mounted buttons of the display.
- Across an IP network (Current controller IP address required).
- Through the Data Manager.

Setup through front buttons



To enter setup mode, hold the **Enter** and **Down** buttons together for approximately 3 seconds until the message "Ent" appears on the display. Now press the Enter button again to enter the function menu. IO will be displayed. Scroll up or down to go through the list.

Setup Function Menu (Common to all types)

| Display | Option | Explained in Paragraph | Display | Option | Explained in Paragraph |
|---------|--|--|---------|--------------------------------|---------------------------------------|
| IO | View Inputs / Outputs and States | Input / output table | nEt | Set/view network configuration | Network Configuration |
| PArA | Set/View Parameters | Set view parameters | SoFt | View software version | |
| Unit | Probe type and Celsius/Fahrenheit option | Set View Unit | FANS | Toggle Fans Only mode | Fans Only |
| PrES | Set Pressure Units | Set Pressure Unit | CASE | Toggle Case Off mode | Case Off |
| diSP | Display whole units or decimal | Display | Ligt | Toggle Lights Only mode | Lights Only |
| dtyP | Set/view display type | Display Type | OFSt | Probe Offset | Probe Offset |
| tyPE | Set/View Controller Type | Set/view controller type | tESt* | Test Mode | See Note Below |
| rtc | Set/view Clock (rtc = Real Time Clock) | Real Time Clock | ESC | Exit Setup mode | |

***Note:** When first powered up the controller will have the 'tESt' option in the menu setup. This allows the user to toggle the relays for testing purposes. Upon entering the menu, the display will show r-01 (relay 1) to r-05 (relay 5), select the desired output and toggle the value from 0 to 1 (confirm by pressing enter) to switch the selected relay.

This option is only available for 30 seconds after power up. After this time, the menu setup will return to its standard options.



Recommended set-up method

If you are not connecting to a network and want to set up the controller through the buttons we recommend you use the following order from the function menu.

rtc. Real time clock (This will automatically if networked to a DM Touch or Mini DM)

- Use the up or down buttons to scroll through the display until the display reads "rtc"
- Press enter. The display will show "t-1". press enter again
- Scroll hours up or down (0 – 23) press enter
- Use up button to select "t-2", press enter
- Scroll minutes up or down (0 – 59) press enter
- Repeat for t-3 (seconds 0 – 59)
- Repeat for t -4 (Days up to 31)
- Repeat for t -5 (months up to 12)
- Repeat for t -6 (Year up to 99)
- Use up button to display "ESC", press enter to display "rtc"

Time clock is now set

type. Set/view controller type

- From the function menu scroll to select 'type', press enter
- Use the up/ down buttons to scroll through case/ coldroom configuration types. (see [configuration table](#) on page 4)
- Press enter.
- Scroll to select "ESC"
- Press enter

Controller type configuration is now set

PArA. Set/view parameters (This can be achieved at the network front end)

- From the function menu, scroll to select 'PArA'
- Pressing Enter while PArA is displayed will enter the parameter menu.
- The first parameter option will be displayed as P-01. Pressing the Up or Down button will present the other parameter options P-02, P-03 etc. See the [parameter list](#) below to find what parameter number corresponds to which actual parameter.
- Pressing the Enter button will show the current value of the selected parameter.
- Press Up or Down to modify the value and press Enter again to save the value.
- The parameter list number will be displayed again.
- Two other options are present in the parameter menu – dFLt and ESC. Selecting ESC will exit the setup mode and save all changes.
- Selecting dFLt will reset all parameters back to the default values for the current type of controller

Unit. Set/view temperature unit and Probe type

From the function menu scroll to, and select Unit. Press enter and the value will be displayed: -

Probe Types

| | |
|-------------------------|--|
| 0 for PT1000 Celsius | 10 for NTC2K25 Celsius |
| 1 for PT1000 Fahrenheit | 11 for NTC2K25 Fahrenheit |
| 2 for NTC2K Celsius | 12 for 5K Celsius |
| 3 for NTC2K Fahrenheit | 13 for 5K Fahrenheit |
| 4 for 470R Celsius | 14 for 6K Celsius |
| 5 for 470R Fahrenheit | 15 for 6K Fahrenheit |
| 6 for 700R Celsius | 16 for NTC10K Celsius |
| 7 for 700R Fahrenheit | 17 for NTC10K Fahrenheit |
| 8 for 3K Celsius | 18 for NTC10K (2) Celsius (USA NTC10K) |
| 9 for 3K Fahrenheit | 19 for NTC10K(2) Fahrenheit (USA NTC10K) |

Use the up or down keys to select the units and press enter.



This function is now complete**PrES. Set Pressure Units**

From the function menu scroll to and select 'PrEs'. Press enter and one of the following values will be shown:

- 0: Set units for any pressure reading to Bar.
- 1: Set units for any pressure reading to Psi.

diSP. Display selection

From the function menu scroll to and select 'diSP'. Press enter and one of the following values will be shown:

- 0: Controller display will show the whole number and tenths value of a temperature reading. (Default)
- 1: Controller display will show temperatures as a whole number.

dtyP. Set / view display type

From the function menu scroll to and select dtyP. Press enter and one of the following values will be shown: -

- 0. Controller will be set to use a Mercury display.
- 1. Controller will be set to use a Coldroom display (PR0152).

Note: The software defaults to 0 for the Mercury display. If using a Mercury 1 display, changing from type 1 to 0 needs to be done through the webpage and can't be done through the display.

Parameter Tables

Not all parameters apply to all controller types. For example P-08 is the Superheat reference which only applies to the PWM EEV variant of controllers (available types on the E are 3, 4, 5 & 6). This parameter will not appear if the controller is a Mechanical variant. In the following table, the type columns on the right hand side will be greyed out if that parameter does not apply to that controller type.

| Number | Parameter | Range °C (°F) | Step | Units | Default LT °C (°F) | Default HT °C (°F) | M Type 1&2 | M Type 3&4 | M Type 5&6 | E Type 3&4 | E Type 5&6 |
|--------|----------------------------------|----------------------------|-------|-------|--------------------------|--------------------------|------------------|------------------|------------------|------------------|------------------|
| P-01 | Cut-in Temp. | -42 to 30 (-43.6 to 86) | 0.1 | Deg | -20 (-4) | 0.0 (32) | | ✓ | ✓ | ✓ | ✓ |
| | Cut-in Temp. (Integral) | -42 to 30 (-43.6 to 86) | 0.1 | Deg | -20 (-4) | 3.5 (38.3) | ✓ | | | | |
| P-02 | Diff. | 0 to 10 (0 to 18) | 0.1 | Deg | 2 (3.6) | 1.5 (2.7) | | ✓ | ✓ | ✓ | ✓ |
| | Diff. (Integral) | 0 to 10 (0 to 18) | 0.1 | Deg | 2.5 (4.5) | 2.5 (4.5) | ✓ | | | | |
| P-03 | Control Weight | 0 to 100 | 1 | % | 50 | 50 | | ✓ | ✓ | ✓ | ✓ |
| | Control Weight (Integral) | 0 to 100 | 1 | % | 40 | 30 | ✓ | | | | |
| P-04 | Display Weight | 0 to 101 | 1 | % | 50 | 50 | | ✓ | ✓ | ✓ | ✓ |
| | Display Weight (Integral) | 0 to 101 | 1 | % | 40 | 30 | ✓ | | | | |
| P-05 | Lag Comp Delay (M Type 1 & 2) | 00:00 to 15:00 | 00:05 | mm:ss | 00:40 | 00:10 | ✓ | | | | |
| | Alarm Weight (E Type) | 0 to 100 | 1 | % | 0 | 0 | | | | ✓ | ✓ |
| P-11 | Slug Display | 0 = Off 1 = On | 1 | | 0 | 0 | ✓ | ✓ | ✓ | ✓ | ✓ |
| P-06 | Anti-SC Time | 00:00 to 15:00 | 00:05 | mm:ss | 03:00 | 03:00 | ✓ | | | | |
| P-07 | Lag Cut Out Diff | 0 to 10 (0 to 18) | 0.1 | Deg | 2.5 (4.5) | 2.5 (4.5) | ✓ | | | | |
| P-08 | Comp Power Up Dly. (M Type) | 00:00 to 05:00 | 00:01 | mm:ss | 00:00 | 00:00 | ✓ | | | | |



| Number | Parameter | Range °C (°F) | Step | Units | Default LT °C (°F) | Default HT °C (°F) | M Type 1&2 | M Type 3&4 | M Type 5&6 | E Type 3&4 | E Type 5&6 |
|--------|----------------------------------|--|-------|-------|--------------------------|--------------------------|------------------|------------------|------------------|------------------|------------------|
| P-08 | Superheat Ref | 0 to12 (7.2 to 21.6) | 0.1 | Deg | 6 (10.8) | 6 (10.8) | | | | ✓ | ✓ |
| P-09 | Response On | 1 to 30 | 1 | | 10 | 10 | | | | ✓ | ✓ |
| P-10 | Response Off | 1 to 30 | 1 | | 10 | 10 | | | | ✓ | ✓ |
| P-10 | Alarm Weight (M Type) | 0 to 100 | 1 | % | 0 | 0 | ✓ | ✓ | ✓ | | |
| P-11 | Control Type | 0 = EEV 1 = EET 2 = EEV/T | 1 | | 0 | 0 | | | | ✓ | ✓ |
| P-51 | EEV Minimum Opening | 0 to 100 | 1 | % | 10 | 10 | | | | ✓ | ✓ |
| P-52 | Superheat Problem | 0 to 12 (0 to 21.6) | 0.1 | Deg | 0 | 0 | | | | ✓ | ✓ |
| P-53 | Superheat EEV Problem Opening | 0 to 100 | 1 | % | 10 | 10 | | | | ✓ | ✓ |
| P-54 | Superheat EEV Problem Time | 00:00 to 99:00 | 01:00 | mm:ss | 03:00 | 03:00 | | | | ✓ | ✓ |
| P-56 | EEV Start Opening | 0 to 100 | 1 | % | 10 | 10 | | | | ✓ | ✓ |
| P-55 | Average Valve Opening | 0 to 100 | 1 | % | 100 | 100 | | | | ✓ | ✓ |
| P-57 | EEV Divide Value | 0 to 100 | 1 | % | 50 | 50 | | | | ✓ | ✓ |
| P-12 | Relay 4 Mode | 0 = Suction Line 1 = Trim Heater 2 = Alarm 3 = Remote 4 = Trim Hub | 1 | | 0 | 0 | | ✓ | | ✓ | |
| | Relay 4 Mode (Coldroom) | 0 = Suction Line 1 = Alarm 2 = Remote | 1 | | 0 | 0 | | | ✓ | | ✓ |
| P-13 | Trim in Defrost | 0 = Off 1 = On | | | 0 | 0 | | ✓ | | ✓ | |
| P-14 | Trim Level | 0 to 100 | 1 | % | 100 | 100 | | ✓ | | ✓ | |
| P-85 | Key-switch Mode | 0 = Case Off 1 = Fans only 2 = toggle 3 = Off | 1 | | 0 | 0 | ✓ | ✓ | ✓ | ✓ | ✓ |
| P-87 | Control Probe type | 0 = Air on Probe 1 = Log Probe | 1 | | 0 | 0 | ✓ | ✓ | ✓ | ✓ | ✓ |
| P-90 | Resistor Case Off | 0 = Disabled 1 = Enabled | | | 0 | 0 | ✓ | ✓ | ✓ | ✓ | ✓ |
| P-92 | Fans temperature mode | 0 = Off 1 = Temperature 2 = Over- temperature 3 = Temp/OT | 1 | | 0 | 0 | ✓ | ✓ | ✓ | ✓ | ✓ |
| P-93 | Fans Off Temperature | -42 to 30 (-43.6 to 86) | 0.1 | Deg | -10 (14) | 8 (46.4) | ✓ | ✓ | ✓ | ✓ | ✓ |
| P-83 | Fan Control | 0 = Off 1 = Run 2 = Pulse | 1 | | 1 | 1 | ✓ | ✓ | ✓ | ✓ | ✓ |
| P-78 | Fan Pulse On | 00:00 to 99:00 | 01:00 | mm:ss | 05:00 | 05:00 | ✓ | ✓ | ✓ | ✓ | ✓ |
| P-79 | Fan Pulse Off | 00:00 to 99:00 | 01:00 | mm:ss | 30:00 | 30:00 | ✓ | ✓ | ✓ | | ✓ |
| P-15 | Probe 5 Select | 0 = Defrost 1 = Monitor | 1 | | 0 | 0 | ✓ | ✓ | ✓ | ✓ | ✓ |
| P-16 | Relay 3 Mode | 0 = Lights 1 = Alarm | 1 | | 0 | 0 | ✓ | ✓ | ✓ | ✓ | ✓ |
| P-17 | Evap Select | 0 = Local 1 = Rem1 2 = Rem2 3 = Rem3 4 = Trans V 5= Trans mA | 1 | | 0 | 0 | | | | ✓ | ✓ |



| Number | Parameter | Range °C (°F) | Step | Units | Default LT °C (°F) | Default HT °C (°F) | M Type 1&2 | M Type 3&4 | M Type 5&6 | E Type 3&4 | E Type 5&6 |
|--------|--|--|-------|-------|--------------------------|--------------------------|------------------|------------------|------------------|------------------|------------------|
| | | 6= Cust V 7= Cust mA | | | | | | | | | |
| P-97 | Control Fail On/Off (Mechanical Valve) | 00:00 to 10:00 | 01:00 | mm:ss | 00:00 | 00:00 | | ✓ | ✓ | | |
| | Control Fail Valve Level (EEV) | 0 to 100 | 0.1 | % | 0 | 0 | | | | ✓ | ✓ |
| P-29 | Probe 3 Resistor function (Mechanical Valve) | 0 =Plant fault 3 N/O 1 =Plant fault 3 N/C | 1 | | 0 | 0 | ✓ | ✓ | ✓ | | |
| | Probe 1 Resistor Function (EEV) | 2 =External Defrost | 1 | | 0 | 0 | | | | ✓ | ✓ |
| P-18 | Service Interval time | 0 to 128 | 1 | KHrs | 60 | 60 | ✓ | ✓ | ✓ | ✓ | ✓ |
| P-19 | Switch Resistors | 0 = Off 1 = On | 1 | | 1 | 1 | ✓ | ✓ | ✓ | ✓ | ✓ |
| P-77 | Trap Stop LLV/Fans | 0 = Off 1 = On | 1 | | 0 | 0 | | | ✓ | | ✓ |
| P-98 | Lights Case Off | 0 = Off 1 = On 2 = Unused | 1 | | 0 | 0 | | ✓ | | ✓ | |
| P-99 | Load Shedding | 0 = Off 1 = Mode 1 2 = Mode 2 | 1 | | 0 | 0 | | ✓ | ✓ | ✓ | ✓ |
| P-100 | Digital Input 1 | Types 1&2; 0 =Plant 1 N/O 1 =Plant 1 N/C 2 =Case Switch 3 =Temp Switch 4 =Defrost 5= Door N/O 6 = Door N/C | 1 | | 0 | 0 | ✓ | ✓ | ✓ | | |
| | | Types 3&4; 0 =Plant 1 N/O 1 =Plant 1 N/C 2 =Case Switch 3 =Temp Switch 4 =Defrost 5= Door N/O 6 = Door N/C | 1 | | 0 | 0 | ✓ | ✓ | ✓ | ✓ | ✓ |
| | | Types 5&6; 0 =Plant 1 N/O 1 =Plant 1 N/C 2 =Case Switch 3 =Temp Switch 4 =Defrost 5 =Door NO 6 =Door NC 7 =Person Trap | 1 | | 5 | 5 | ✓ | ✓ | ✓ | ✓ | ✓ |
| P-101 | Digital Input 2 | Types 1&2; 0 =Plant 2 N/O 1 =Plant 2 N/C 2 =Case Switch 3 =Temp Switch 4 =Defrost 5= Door N/O 6 = Door N/C | 1 | | 3 | 3 | ✓ | ✓ | ✓ | | |
| | | Types 3&4; 0 =Plant 2 N/O 1 =Plant 2 N/C 2 =Case Switch 3 =Temp Switch 4 =Defrost | 1 | | 1 | 1 | ✓ | ✓ | ✓ | ✓ | ✓ |



| Number | Parameter | Range °C (°F) | Step | Units | Default LT °C (°F) | Default HT °C (°F) | M Type 1&2 | M Type 3&4 | M Type 5&6 | E Type 3&4 | E Type 5&6 |
|--------|--|--|-------|-------|--------------------------|--------------------------|------------------|------------------|------------------|------------------|------------------|
| | | 5= Door N/O 6 = Door N/C | | | | | | | | | |
| | | Types 5&6; 0 =Plant 2 N/O 1 =Plant 2 N/C 2 =Case Switch 3 =Temp Switch 4 =Defrost 5 =Door NO 6 =Door NC 7 =Person Trap | 1 | | 6 | 6 | ✓ | ✓ | ✓ | ✓ | ✓ |
| P-102 | Cut In Offset | -30 to 30 (-22 to 86) | 1 | Deg | 5 | 5 | ✓ | ✓ | ✓ | ✓ | ✓ |
| P-103 | Evap Cust Off | 0.0 – 20.0 | 0.1 | | 0.0 | 0.0 | | | | ✓ | ✓ |
| P-104 | Evap Cust High | 0.0 – 20.0 | 0.1 | | 0.0 | 0.0 | | | | ✓ | ✓ |
| P-20 | Alarm Delay | 00:00 to 99:00 | 01:00 | mm:ss | 20:00 | 20:00 | ✓ | ✓ | ✓ | ✓ | ✓ |
| P-21 | Under Temp Alm | -49 to 60 (-56.2 to 140) | 0.1 | Deg | -30 (-22) | -2 (28.4) | ✓ | ✓ | ✓ | ✓ | ✓ |
| P-22 | Over Temp Alarm | -49 to 60 (-56.2 to 140) | 0.1 | Deg | -15 (5) | 5 (41) | ✓ | ✓ | ✓ | ✓ | ✓ |
| P-23 | Log Probe Type | 0 =Off 1 =Logging 2 =Log/Alarm 3 =Df/Alm | 1 | | Off | Off | ✓ | ✓ | ✓ | ✓ | ✓ |
| P-24 | Slug Log Probe | 0 = Off 1 = On | | | Off | Off | ✓ | ✓ | ✓ | ✓ | ✓ |
| P-25 | Log Alarm Delay | 00:00 to 03:00 | 00:01 | hh:mm | 00:20 | 00:20 | ✓ | ✓ | ✓ | ✓ | ✓ |
| P-26 | Log UT Alarm | -49 to 60 (-56.2 to 140) | 0.1 | Deg | -35 (-31) | -1 (30.2) | ✓ | ✓ | | ✓ | ✓ |
| | Log UT Alarm (Mechanical Valve Coldroom) | -49 to 60 (-56.2 to 140) | 0.1 | Deg | -30 (22) | -2 (28.4) | | | ✓ | | |
| P-27 | Log OT Alarm | -49 to 60 (-56.2 to 140) | 0.1 | Deg | -12 (10.4) | 6 (42.8) | ✓ | ✓ | | ✓ | ✓ |
| | Log OT Alarm (Mechanical Valve Coldroom) | -49 to 60 (-56.2 to 140) | 0.1 | Deg | -15 (5) | 5 (41) | | | ✓ | | |
| P-28 | Monitor OT Alarm | -49 to 60 (-56.2 to 140) | 0.1 | Deg | 20 (68) | 20 (68) | ✓ | ✓ | ✓ | ✓ | ✓ |
| P-58 | Probe 2 Alarm (E Type) | 0 = Off 1 = On | | | 1 | 1 | | | | ✓ | ✓ |
| P-75 | Def Log AlmDey | 00:00 to 03:00 | 00:01 | hh:mm | 00:20 | 00:20 | ✓ | ✓ | ✓ | ✓ | ✓ |
| P-76 | Def Log O/T Alm | -49.0 – 128.0 | 0.1 | Deg | -12.0 | 6.0 | ✓ | ✓ | ✓ | ✓ | ✓ |
| P-40 | Defrost Mode | 0 = Local 1 = Remote 2 = External | | | Local | Local | ✓ | ✓ | ✓ | ✓ | ✓ |
| P-41 | Defrost Start | 00:00 to 23:59 | 00:01 | hh:mm | 01:00 | 01:00 | ✓ | ✓ | ✓ | ✓ | ✓ |
| P-42 | Defrosts per Day | 0 to 8 | 1 | | 6 | 6 | ✓ | ✓ | ✓ | ✓ | ✓ |
| P-43 | No Defrost Time | 0 to 25 | 1 | hours | 8 | 8 | | ✓ | ✓ | | |
| | No Defrost Time (Integral) | 0 to 25 | 1 | hours | 8 | 5 | ✓ | | | | |
| | No Defrost Time (EEV) | 0 to 25 | 1 | hours | 12 | 12 | | | | ✓ | ✓ |
| P-44 | Def Terminate Temp. | -42 to 30 (-43.6 to 86) | 0.1 | Deg | 14 (57.2) | 10 (50) | | ✓ | ✓ | ✓ | ✓ |
| | Def Terminate Temp. (Integral) | -42 to 30 (-43.6 to 86) | 0.1 | Deg | 10 (50) | 10 (50) | ✓ | | | | |
| P-45 | Def Min Time | 00:00 to 99:00 | 01:00 | mm:ss | 05:00 | 05:00 | ✓ | ✓ | ✓ | ✓ | ✓ |
| P-46 | Def Max Time | 00:00 to 99:00 | 01:00 | mm:ss | 24:00 | 24:00 | | ✓ | ✓ | ✓ | ✓ |
| | Def Max Time (Integral) | 00:00 to 99:00 | 01:00 | mm:ss | 25:00 | 30:00 | ✓ | | | | |



| Number | Parameter | Range °C (°F) | Step | Units | Default LT °C (°F) | Default HT °C (°F) | M Type 1&2 | M Type 3&4 | M Type 5&6 | E Type 3&4 | E Type 5&6 |
|--------|---|--|-------|-------|--------------------------|--------------------------|------------------|------------------|------------------|------------------|------------------|
| P-47 | Drain Down | 00:00 to 24:00 | 00:15 | mm:ss | 01:30 | 01:30 | | ✓ | ✓ | ✓ | ✓ |
| | Drain Down (Integral) | 00:00 to 24:00 | 00:15 | mm:ss | 01:30 | 00:30 | ✓ | | | | |
| P-48 | Recovery Time | 00:00 to 99:00 | 01:00 | mm:ss | 30:00 | 30:00 | ✓ | ✓ | ✓ | ✓ | ✓ |
| P-89 | Pump Down Time | 00:00 to 99:00 | 01:00 | mm:ss | 00:00 | 00:00 | ✓ | ✓ | ✓ | ✓ | ✓ |
| P-86 | Fan Delay mode | 0 = Time 1 = Temp | 1 | | 0 | 0 | ✓ | ✓ | ✓ | ✓ | ✓ |
| P-49 | Fan Delay Time Types (Cabinet) | 00:00 to 99:00 | 01:00 | mm:ss | 00:00 | 00:00 | | ✓ | | ✓ | |
| | Fan Delay Time Types (Integral & Coldroom) | 00:00 to 99:00 | 01:00 | mm:ss | 03:00 | 03:00 | ✓ | | ✓ | | ✓ |
| P-88 | Fan Delay Temp | -42 to 30 (-43.6 to 86) | 0.1 | Deg | -20 (-4) | 0.0 (32) | ✓ | ✓ | ✓ | ✓ | ✓ |
| P-50 | Fans In Defrost | 0 = Off 1 = On | | | On | On | ✓ | ✓ | | ✓ | |
| | Fans In Defrost (Coldroom) | 0 = Off 1 = On | | | Off | Off | | | ✓ | | ✓ |
| P-91 | Defrost Type M & E | 0 = Elec. 1 = Elec/Cln | 1 | | 0 | 0 | | | | | |
| | Defrost Type (Integral) | 0 = Elec. 1 = Gas. 2 = Elec Cln 3 = Gas 2. | | ✓ | | | ✓ | ✓ | ✓ | ✓ | |
| P-94 | Defrost Hold | 0 = Off 1 = On | | | Off | Off | | ✓ | ✓ | ✓ | ✓ |
| P-95 | Defrost Skip | 0 = Off 1 = On | | | Off | Off | ✓ | ✓ | ✓ | ✓ | ✓ |
| P-96 | Defrost Skip Time | 00:00 to 99:00 | 01:00 | mm:ss | 12:00 | 12:00 | ✓ | ✓ | ✓ | ✓ | ✓ |
| P-51 | Display Def Button | 0 = No 1 = Yes | | | Yes | Yes | ✓ | ✓ | ✓ | | |
| P-120 | | | | | | | | | | | ✓ |
| P-80 | Door Alarm Delay | 00:00 to 99:00 | 01:00 | mm:ss | 20:00 | 20:00 | ✓ | ✓ | ✓ | ✓ | ✓ |
| P-81 | Door Closes LLV (Parameter has no effect in this variant) | 0 = No 1 = Yes | | | No | No | | | ✓ | | ✓ |
| P-82 | Door Stops Fan | 0 = No 1 = Yes | | | No | No | ✓ | ✓ | ✓ | ✓ | ✓ |
| P-84 | Door Fan Delay | 00:00 to 99:00 | 01:00 | mm:ss | 00:00 | 00:00 | ✓ | ✓ | | ✓ | |
| P-60 | Lights Mode | 0 = Local 1 = Remote 2 = Man Off 3 = Man On | | | Local | Local | ✓ | ✓ | ✓ | ✓ | ✓ |
| P-61 | Sun Lights On | 00:00 to 23:59 | 00:01 | hh:mm | 08:00 | 08:00 | ✓ | ✓ | ✓ | ✓ | ✓ |
| P-62 | Sun Lights Off | 00:00 to 23:59 | 00:01 | hh:mm | 20:00 | 20:00 | ✓ | ✓ | ✓ | ✓ | ✓ |
| P-63 | Mon Lights On | 00:00 to 23:59 | 00:01 | hh:mm | 08:00 | 08:00 | ✓ | ✓ | ✓ | ✓ | ✓ |
| P-64 | Mon Lights Off | 00:00 to 23:59 | 00:01 | hh:mm | 20:00 | 20:00 | ✓ | ✓ | ✓ | ✓ | ✓ |
| P-65 | Tue Lights On | 00:00 to 23:59 | 00:01 | hh:mm | 08:00 | 08:00 | ✓ | ✓ | ✓ | ✓ | ✓ |
| P-66 | Tue Lights Off | 00:00 to 23:59 | 00:01 | hh:mm | 20:00 | 20:00 | ✓ | ✓ | ✓ | ✓ | ✓ |
| P-67 | Wed Lights On | 00:00 to 23:59 | 00:01 | hh:mm | 08:00 | 08:00 | ✓ | ✓ | ✓ | ✓ | ✓ |
| P-68 | Wed Lights Off | 00:00 to 23:59 | 00:01 | hh:mm | 20:00 | 20:00 | ✓ | ✓ | ✓ | ✓ | ✓ |
| P-69 | Thu Lights On | 00:00 to 23:59 | 00:01 | hh:mm | 08:00 | 08:00 | ✓ | ✓ | ✓ | ✓ | ✓ |
| P-70 | Thu Lights Off | 00:00 to 23:59 | 00:01 | hh:mm | 20:00 | 20:00 | ✓ | ✓ | ✓ | ✓ | ✓ |
| P-71 | Fri Lights On | 00:00 to 23:59 | 00:01 | hh:mm | 08:00 | 08:00 | ✓ | ✓ | ✓ | ✓ | ✓ |
| P-72 | Fri Lights Off | 00:00 to 23:59 | 00:01 | hh:mm | 20:00 | 20:00 | ✓ | ✓ | ✓ | ✓ | ✓ |
| P-73 | Sat Lights On | 00:00 to 23:59 | 00:01 | hh:mm | 08:00 | 08:00 | ✓ | ✓ | ✓ | ✓ | ✓ |
| P-74 | Sat Lights Off | 00:00 to 23:59 | 00:01 | hh:mm | 20:00 | 20:00 | ✓ | ✓ | ✓ | ✓ | ✓ |
| P-30 | Broadcast ID | 0 to 999 | 1 | | 0 | 0 | | | | ✓ | ✓ |
| | Probe 2 Alarm (M Type) | 0 = Off 1 = On | | | 1 | 1 | ✓ | ✓ | ✓ | | |
| P-31 | Refrigerant | 0 to 38 | 1 | | 0 | 0 | | | | ✓ | ✓ |



| Number | Parameter | Range °C (°F) | Step | Units | Default LT °C (°F) | Default HT °C (°F) | M Type 1&2 | M Type 3&4 | M Type 5&6 | E Type 3&4 | E Type 5&6 |
|--------|------------------|---------------------------|-------|-------|--------------------|--------------------|------------|------------|------------|------------|------------|
| P-110 | Ref Weight | 0 to 100 | 1 | % | 0 | 0 | | | | ✓ | ✓ |
| P-32 | Pressure Units | 0 = Absolute 1 = Gauge | 1 | | 0 | 0 | | | | ✓ | ✓ |
| P-33 | Evap Offset | 0.0 to 1.0 | 0.1 | | 0.0 | 0.0 | | | | ✓ | ✓ |
| P-34 | Glide | -15.0 to 15.0 | 0.1 | Deg | 0.0 | 0.0 | | | | ✓ | ✓ |
| P-35 | Trans Span* | -3.4 to 180.0 | 0.1 | Bar | 13.8 | 13.8 | | | | ✓ | ✓ |
| P-36 | Trans Offset* | -3.4 to 180.0 | 0.1 | Bar | 0.0 | 0.0 | | | | ✓ | ✓ |
| P-37 | MOP Cut-in | -3.4 to 180.0 | 0.1 | Bar | 3.4 | 3.4 | | | | ✓ | ✓ |
| P-38 | MOP Diff | -3.4 to 180.0 | 0.1 | Bar | 0.3 | 0.3 | | | | ✓ | ✓ |
| P-39 | MOP Delay | 00:00 to 02:00 | 00:01 | mm:ss | 00:05 | 00:05 | | | | ✓ | ✓ |
| P-150 | Custom A1 | -999 to 999 | 1 | | 0 | 0 | | | | ✓ | ✓ |
| P-151 | Custom B1 Hi | -999 to 999 | 1 | | -220 | -220 | | | | ✓ | ✓ |
| P-152 | Custom B1 Lo | 0 to 999 | 1 | | 384 | 384 | | | | ✓ | ✓ |
| P-153 | Custom C1 | -999 to 999 | 0.1 | | 262.5 | 262.5 | | | | ✓ | ✓ |
| P-154 | Custom A2 | -999 to 999 | 1 | | 0 | 0 | | | | ✓ | ✓ |
| P-155 | Custom B2 Hi | -999 to 999 | 1 | | -220 | -220 | | | | ✓ | ✓ |
| P-156 | Custom B2 Lo | 0 to 999 | 1 | | 384 | 384 | | | | ✓ | ✓ |
| P-157 | Custom C2 | -999 to 999 | 0.1 | | 262.5 | 262.5 | | | | ✓ | ✓ |
| P-121 | Allow SH Offset | 0 = Off 1 = On | | | 0 | 0 | | | | ✓ | ✓ |
| dFLt | Restore defaults | | | | | | ✓ | ✓ | ✓ | ✓ | ✓ |

* Transducer Span and Offset allows for the full range of the transducer to be used by the Mercury Controller. 'Span' is the full range of the transducer, 'Offset' is the value below zero.

Example: RDM PR0162 with range -1 bar to 65 bar

Span would be 66 Bar (957 psi) Offset would be -1 Bar (-15 psi)

Refrigerant Table for P-31

| No. | Gas | No. | Gas | No. | Gas | No. | Gas | No. | Gas |
|-----|---------|-----|-------|-----|-------|-----|-------|-----|----------|
| 0 | None | 8 | R401C | 16 | R502 | 24 | R449A | 32 | R454A |
| 1 | Custom* | 9 | R402A | 17 | R503 | 25 | R513A | 33 | R471A |
| 2 | R32 | 10 | R402B | 18 | R507 | 26 | R454C | 34 | R515B |
| 3 | R134a | 11 | R404A | 19 | R717 | 27 | R455A | 35 | R600A |
| 4 | R142B | 12 | R407A | 20 | R290 | 28 | R448A | 36 | R1234YF |
| 5 | R227 | 13 | R407B | 21 | R744 | 29 | R449B | 37 | R1234ZEE |
| 6 | R401A | 14 | R407C | 22 | R407F | 30 | R450A | 38 | R1270 |
| 7 | R401B | 15 | R500 | 23 | R410A | 31 | R452B | | |

***Note:** When P-31 is set to Custom, the controller will use the settings in P-150 – P-157.

Parameter Descriptions

| Number | Parameter | Description |
|--------|----------------|---|
| P-01 | Cut-in Temp | Temperature at which the EEV/ LLV or compressor will switch on. |
| P-02 | Diff | Differential temperature below the cut-in temperature. The EEV/ LLV or lead compressor switches off when below this temperature. |
| P-03 | Control Weight | Percentage of the Air-On temperature that is used to calculate the control temp. The remaining percentage will be used on the Air-Off temperature. Example, P-03 set to 30% Control temp = 30% Air-on + 70% Air-off |
| P-04 | Display Weight | As above only applied to the display temperature. Note If this is set to 101, the display will show the Product Probe temperature. |



| Number | Parameter | Description |
|--------|--------------------------------|--|
| P-05 | Lag Comp Delay | Delay before the second compressor is switched on if the temperature is still above set-point. |
| | Alarm Weight | Percentage of the Air-On temperature that is used to calculate the over temperature alarm. |
| P-06 | Anti-SC Time | Allows the user to set the compressor for a given number of starts/hour |
| P-07 | Lag Cut Out Diff | Diff below the Cut-In Temp the lag compressor switches off. Note: Lead and Lag compressors rotate duty after every defrost cycle. |
| | | Single Compressor Operation To disable compressor B operation and use only a single compressor for control set parameter P-07 to 0. This will allow the controller work with just one compressor (A) and ignore compressor B. |
| P-08 | Superheat Ref (E Types) | The controller will attempt to maintain this superheat value |
| P-08 | Comp. Power Up Delay (M Types) | When the controller is powered on this provides an optional delay period before the compressor(s) starts up subject to there being a cooling demand. |
| P-09 | Response on | Allows the user to speed up the EEV on time. With 30 providing the quickest response and 1 providing the slowest response. |
| P-10 | Response off | Allows the user to speed up the EEV off time. With 30 providing the quickest response and 1 providing the slowest response. |
| | Alarm Weight | As per P-05 |
| P-11 | Control Type (E Types) | Allows the user to select either EEV control, EET control or EEV/EET control. Note the Evaporator Temperature probe should be fitted to the coldest point in the evaporator. EEV uses the superheat as its main reference with the cabinet temperature as a secondary control. EET use the cabinet temperature as its main reference. EEV/EET uses cabinet temperature as the main control until the SH gets close to the SH reference point, then it switches to EEV control, it switches back to EET control when the SH reference is satisfied. See: Valve Control Type |
| P-11 | Slug Display (M Types) | Provides an electronic slugging or damping to the temperature display value compared to the control temperature. |
| P-51 | EEV Minimum Opening | Sets the minimum valve opening level, during normal operation the valve will not go below this level. (Default 10%) IF used in conjunction with a Mercury Pressure Hub PR0018-PHI or Intuitive Switch PR0757/758, remote pressure from Plant Pack or local pressure from a daughter card, then the Minimum value should be set at 0% |
| P-52 | Superheat Problem | Sets the point at which the algorithm will go to the "EEV Problem" state due to low superheat. For example if this parameter is set to 0 Degrees and the Superheat value falls to 0 degrees or below, for the duration of P-54, then the controller will enter the superheat problem state. |
| P-53 | Superheat EEV Problem Opening | Sets the valve open position when entering the "Superheat EEV Problem" state. |
| P-54 | Superheat EEV Problem Time | Sets the time the algorithm stays in the "Superheat EEV Problem" state. |
| P-56 | EEV Start Opening | Sets the initial valve opening % which is used when there is a demand for cooling or when the device is first powered on. |
| P-55 | Average Valve Opening | Normally the valve during recovery will open to the last average position. This setting allows for that value to be reduced by said percentage. For example if the average valve opening is calculated as 80% and P-55 is set to 50% then the valve will open at 40%. |
| P-57 | EEV Divide value | When the Mercury controller generates a MOP alarm the controller reduces the maximum valve opening to this percentage. For example if this parameter is set to 50% and the MOP alarm is generated then the maximum valve opening will be limited to 50%. Therefore as the controller pulses the valve the maximum the valve will open is 50%. Note P-51 EEV Minimum opening overrides the valve output operation and the valve will not pulse below this setting. |
| | | Please see Maximum Operating Pressure (MOP) note. Please note parameters P-51 through to P-57 should not be altered without first understanding the effects they may have on the case operation. If incorrectly set they may have undesired affects. |
| P-12 | Relay 4 Mode | Relay 4 can be a Suction, Trim Heater, Alarm, Remote or Trim Hub relay. <ul style="list-style-type: none"> ➢ Suction – set for Suction Line Valve operation. ➢ Trim Heater – set as trim relay which pulses in accordance with P-14 or the Data |



| Number | Parameter | Description |
|--------|--------------------------|---|
| | | <p>Manager Energy feature trim control.</p> <ul style="list-style-type: none"> ➤ Alarm – The alarm relay is energised for no alarm. Use the NC and Common for “Loop make” on alarm or use the NO and Common for “Loop break” on alarm. Note: shows as ‘Alm Relay 1’ in IO list. ➤ Remote – The relay is available for remote purposes such as the Data Manager GP timer channel or Data Builder software. ➤ Trim Hub – Relay is pulsed in accordance with the Trim Control feature present in the Mercury Switch (PR0018-PHI) or Intuitive Switch (PR0757/758). Please see the Mercury/Intuitive switch user document for further details. |
| P-13 | Trim in Defrost | Allows the trims to be off or on during a defrost. |
| P-14 | Trim Level | Sets a percentage level, of a 5-minute period, to pulse the trim heater relay off/on. Example: - P-14 set to 50% = 2.5 minutes on, 2.5 minutes off. If the controller is networked to a Data Manager operating the energy feature Trim Control then the Data Manager feature will override this parameter setting. Please refer to the Data Manager user document for further details. Note the trims are turned off when an over temperature alarm occurs. |
| P-85 | Key-switch Mode | Allows the keys switch to be: - <ul style="list-style-type: none"> ➤ Single turn for case off (Case off mode) ➤ Single turn for Fans only (Fans Mode) ➤ Single turn for case off, double turn for fans only (Toggle mode) |
| P-87 | Control Probe type | Switches between using the air-on probe and the Logging probe. Note the control and display temperature will still be a derivative of the weighted Average of the control probe + Air-off probe |
| P-90 | Resistor Case Off | Turns on/off the switched resistor case off function |
| P-92 | Fans temperature mode | Allows the user to set the fans to turn off when: - <ul style="list-style-type: none"> ➤ A pre-determined temperature is reached (P93) ➤ When an over-temperature alarm is present ➤ When either P93 is reached or an OT alarm is present |
| P-93 | Fans Off Temperature | Temperature for the above (P92) operation. Note the defrost termination probe is the source of the temperature reading used in this feature. If the defrost termination probe isn't fitted then a similar process to P-44 is used. |
| P-83 | Fan Control | <p>This feature allows for coldroom fans to be stopped when the cabinet/coldroom is down to temperature thus saving energy. This feature is present in both the M and E software.</p> <ul style="list-style-type: none"> ➤ Off – When the LLV closes the fans stay on for the Fan Pulse On (P-78) time before going off until the LLV next operates. ➤ Run – fans operate as per the normal control strategy. ➤ Pulse – When the LLV closes the fans will stop when the Fan Pulse On parameter (P-78) time expires. The fans then remain off for the Fan Pulse Off time (P-79). When the parameter Fan Pulse Off time expires the fans come back on for the Fan Pulse on time. The cycle then repeats. The fans resume normal operation if the LLV operates. The fans pulse on/off to ensure the circulation of air within the coldroom. <p>Placement of the temperature control probes is important when using this feature</p> |
| P-78 | Fan Pulse On | The duration of the fans are pulsed on in Fan Control. |
| P-79 | Fan Pulse Off | The duration of the fans are pulsed off in Fan Control. |
| P-15 | Probe 5 Select | This input can be used as a defrost termination probe (default) or as a monitor probe with an OT alarm level (P-28) |
| P-16 | Relay 3 mode | This changes the function of relay 3 from Lights (default) to an alarm relay. The alarm relay is energised for no alarm. Use the NC and Common for “Loop make” on alarm or use the NO and Common for “Loop break” on alarm. Note: shows as ‘Alm Relay 2’ in IO list. |
| P-17 | Evap Select | <p>This allows the control algorithm to use either, the Evaporator in probe temperature, a remote temperature input in place of the Evaporator in value or a transducer connected to the controller via the transducer inputs.</p> <p>In the event of no remote value being received, the control algorithm will revert to using the evaporator in probe value until the remote value is restored.</p> <p>Please see: EEV Control Using Pressure.</p> |
| P-97 | Control Fail Valve Value | This value is used in the event of a control probe fail; In the EEV control algorithm the valve will remain at this opening until the probe fault has been cleared. Please note the incorrect setting of this value may result in flood back causing damage to the pack compressors. Do not adjust this parameter if you are unsure of the consequences. In M software this is the value to which the LLV/compressor relay will be pulsed open/closed. For example if set to 2 |



| Number | Parameter | Description |
|---------------|-----------------------------------|--|
| | | minutes then the LLV will be open for 2 minutes and then closed for two minutes. This process will continue until the control probe fail has been rectified. |
| P-29 | Probe 1 or Probe 3 Resistor | Selects whether the switched resistor invokes either a Plant fault or an External Defrost. If E software then probe input 1 is used. If M software then probe input 3 is used. |
| P-18 | Service Interval Time (Run Hours) | Time (in 1000 x hours) before the service icon (Spanner icon) comes on. The Run Hours timer increments based on the number of hours the controller has been powered up and running. Reset the spanner icon to off by changing this parameter to 0 and then back to the desired service interval. This process also resets the Run Hours value to 0. To view the current Run Time value refer to the I/O list. |
| P-19 | Switch Resistors | Enables switched resistors to be used for Plant Faults, External Defrosts, Case Clean, Person Trap, Door Switch See : Switched Resistor Values |
| P-77 | Trap Stops LLV/Fans | When person trap input is activated the LLV closes and Fans are stopped. Normal operation resumes when the person trap input is deactivated. |
| P-98 | Lights Case Off | Used to place the controller into Case Off when its lighting timer is in the off state. When the lighting timer is in the on state the controller follows its normal control operation. This feature is disabled if the set point (P-01) is below 6°C. Please note that when the controller is in case off all alarms are inhibited and all outputs are turned off. Therefore care must be taken when enabling this parameter. <ul style="list-style-type: none"> ➢ Off – Feature is not used and only the controller lights relay follows the lighting timer status. ➢ On – Feature is in use and controller will be in Case Off whenever the lights timer is in the off state. ➢ Unused – This selection has no effect and should not be used. Please select from either Off or On. This feature operates in either Local, using controller RTC, or Remote, using Data Manager GP timer channel, lighting applications. |
| P-99 | Load Shedding | <ul style="list-style-type: none"> ➢ Off – Feature is not used ➢ Mode 1 – Case goes to Load Shedding Mode 1 (Valve open and fans off) ➢ Mode 2 – Case goes to Load Shedding Mode 2 (Valve closed and fans off) See: Load Shedding |
| P-100 / P-101 | Digital Input 1 / Digital Input 2 | Sets the status input type for the two Digital Inputs; <ul style="list-style-type: none"> ➢ Plant 1/2 – When the DI is activated, it would alarm Plant Fault 1/2 (N/O or N/C) ➢ Case Switch – Would carry out the operation set on the 'Key Switch mode' (p-85) ➢ Temp Switch – Adds temperature setpoint offset value set in P-102 ➢ Defrost – The DI activation would signal the unit to go into a defrost (must be set to external df). ➢ Door – The DI activation would signal if the door is open or closed. ➢ Person Trap – If the DI signal is received, it would activate a Person Trap alarm. |
| P-102 | Cut In Offset | The value added to the Cut-In Setpoint, OT and UT alarm thresholds when a temperature offset is applied. This can be done from a digital input set to 'Temp Switch' or via a Data Manager TDB command. |
| P-103 | Evap Cust Off | Offset of 0 for the locally connected transducer. For example, if the parameter value is set to 1 and P-104 is set to 4 then this will give the transducer a span of 1 – 4. |
| P-104 | Evap Cust High | High Limit of the local transducer |
| P-20 | Alarm Delay | Delay for the over and under-temperature alarms |
| P-21 | UT Alarm | Under temperature alarm set point. This alarm uses the control temperature. |
| P-22 | OT Alarm | Over temperature alarm set point. This alarm uses the weighted alarm temperature (See P-05) |
| P-23 | Log Probe Type | Allows the user to set the logging probe mode: - <ul style="list-style-type: none"> ➢ Off ➢ Logging with no alarms ➢ Logging with alarms ➢ Logging with alarms during defrost |
| P-24 | Slug Log Probe | Applies a damping factor. This can be used to make a standard probe have the same temperature response as a logging probe. |
| P-25 | Log Alarm Delay | Delay for the Logging probe over and under-temperature alarms. |
| P-26 | Log UT Alarm | Logging probe under temperature alarm set point. |
| P-27 | Log OT Alarm | Logging probe over temperature alarm set point. |
| P-28 | Monitor OT Alarm | Monitor probe over temperature alarm set point. |



| Number | Parameter | Description |
|--------|-------------------|---|
| P-58 | Probe 2 Alarm | Allows user to disable Probe 2 alarms if probe is not fitted. |
| P-75 | Def Log AlmDey | Delay for the Logging probe over temperature alarms that occur during a defrost. |
| P-76 | Def Log O/T Alm | Logging probe over temperature alarm set point during a defrost. |
| P-40 | Defrost Mode | Allows the user to set the defrost mode: - <ul style="list-style-type: none"> ➢ Local (Uses the internal parameters P-41 and P-42) ➢ Remote (Requires a defrost schedule in the front end) ➢ External (uses a switched resistor in input 1 or 3 (M)). When this signal is present a defrost is initiated. <p>Note: If the external defrost signal is not removed then the controller will defrost according to the "No Defrost" time and a missed defrost alarm will be generated. See P-29 for external defrost signal setup.</p> |
| P-41 | Defrost Start | When defrost mode is set to "Local", this is the start time for the 1 st defrost |
| P-42 | Defrosts per Day | When defrost mode is set to "Local", this is the number of defrosts per day equally spaced from the start time. |
| P-43 | No Defrost Time | If the controller misses a defrost command for any reason, a defrost will initiate after this time has elapsed from the last defrost. Normally set to 2 hours over the normal defrost period. |
| P-44 | Def Terminate | The defrost will terminate (defrost control relay off) when the temperature of the defrost termination probe reaches this value. If the "defrost termination" probe is not fitted, defrost termination will occur when: - The "coil in" probe reaches the set point (If fans are selected as "off during defrost") Or The "air off" probe reaches the set point (If fans are selected as "on during defrost"). If the "coil in" probe is not fitted, the "air off" probe will be used. |
| P-45 | Def Min Time | Minimum time that a defrost will use, the defrost cycle cannot terminate until this time has elapsed. If termination temperature is reached during this period, the defrost control relay is turned off but the controller will remain in defrost (no cooling) until the end of the defrost min period. |
| P-46 | Def Max Time | Time period after the start of the defrost cycle that defrosts are allowed to terminate. If the defrost termination temperature is not reached by the end of this period the defrost cycle will end and return to normal refrigeration. |
| P-47 | Drain Down | The period after defrost max to allow the draining of any surplus water. |
| P-48 | Recovery Time | The LLV is switched on at the start of this period to allow the temperature to recover to the normal operating point. This period also inhibits the OT alarm. Note that if the air-off temperature is still above the OT alarm setpoint when this period expires, an immediate OT alarm occurs; there is not a further alarm delay. |
| P-89 | Pump Down Time | Time period before the defrost min period to allow for a pump down |
| P-86 | Fan Delay mode | This parameter allows the fans start after a drain-down period to be delayed, either by time (P-49) or when the temperature point (P-88) is reached. This parameter uses the same probe strategy as the defrost terminate. |
| P-49 | Fan Delay | Time after a drain-down period before the fans start if P-86 is set to time |
| P-88 | Fan Delay Temp | Temperature at which the fans start after a drain-down period when P-86 is set to temperature. |
| P-50 | Fans In Defrost | Allows the user to set the fans on or off in defrost. |
| P-94 | Defrost Hold | Turns the defrost hold feature on and off. When switched on, the controller can be held in defrost until a remote command from the front end starts the recovery process. |
| P-95 | Defrost Skip | Allows user to enable/disable defrost skip. This feature allows the controller to skip defrosts. If the current defrost terminates on temperature, then the controller will skip the next scheduled defrost providing the previous defrost terminated before the defrost skip time (P-96). |
| P-96 | Defrost Skip Time | Time factor used in defrost skip. The previous defrost has to terminate before this value expires to allow the controller to skip a defrost. |
| P-91 | Defrost Type | Electric – Defrost heater will go off during defrost min. period, if defrost termination is achieved, and will stay off. Gas (Mobile) – If Gas is selected, one compressor is kept running for the duration of the defrost cycle. Electric Cin – Defrost heater will go off during defrost min. period if defrost termination is achieved but will then cycle on and off around the termination temperature setpoint until the end of the defrost min. period. There is no differential around the termination temperature. |



| Number | Parameter | Description |
|--------|------------------------|---|
| | | Gas 2(Mobile) – If Gas 2 is selected, both compressors is kept running for the duration of the defrost cycle. |
| P-80 | Door alarm delay | Delay after the door open input is activated before the alarm occurs. |
| P-81 | Door Closes Valve | This parameter has no effect. The valve will operate in conjunction with the fan strategy when the door is opened (See P-82 below). |
| P-82 | Door Stops Fans | This parameter is used to stop the fans and close the valve if the door opens. If the door remains open then the fans and valve will resume normal operation on the expiry of the door alarm delay (P-80). |
| P-84 | Door Fan Delay | If Parameter Door Stops Fans (P-82) is set to On the fans and valve will switch on again after this delay period if the door is left open. |
| P-60 | Lights Mode | Allows the user to set the lights mode: - <ul style="list-style-type: none"> ➢ Always off ➢ Always on ➢ Use a local schedule P-61 to P-74) ➢ Use a remote schedule (Set up in the system front end) |
| P-61 | Sun Lights On | When P-60 is set to Local, Sunday on time |
| P-62 | Sun Lights Off | When P-60 is set to Local, Sunday off time |
| P-63 | Mon Lights On | When P-60 is set to Local, Monday on time |
| P-64 | Mon Lights Off | When P-60 is set to Local, Monday off time |
| P-65 | Tue Lights On | When P-60 is set to Local, Tuesday on time |
| P-66 | Tue Lights Off | When P-60 is set to Local, Tuesday off time |
| P-67 | Wed Lights On | When P-60 is set to Local, Wednesday on time |
| P-68 | Wed Lights Off | When P-60 is set to Local, Wednesday off time |
| P-69 | Thu Lights On | When P-60 is set to Local, Thursday on time |
| P-70 | Thu Lights Off | When P-60 is set to Local, Thursday off time |
| P-71 | Fri Lights On | When P-60 is set to Local, Friday on time |
| P-72 | Fri Lights Off | When P-60 is set to Local, Friday off time |
| P-73 | Sat Lights On | When P-60 is set to Local, Saturday on time |
| P-74 | Sat Lights Off | When P-60 is set to Local, Saturday off time |
| P-30 | Broadcast ID | ID of Plant Controller being used to broadcast Suction Pressure The Broadcast ID is derived from the Rotary Switch positions set on the Plant controller which is providing the remote suction pressure. Note: No two Plant controllers on a local area network can have the same rotary switches positions set. This will have adverse effects on control. |
| | Probe 2 Alarm (M Type) | See P-58 |
| P-31 | Refrigerant | Type of refrigerant used in system. See: Refrigerant Table above |
| P-110 | Ref Weight | When using a local pressure transducer or a transmitted pressure from a pack controller is used to calculate superheat, the Mercury controller can use a weighted average of liquid pressure and vapour pressure to calculate the temperature. When the refrigerant weight parameter is set to 0% then the liquid pressure is used (bubble), when set to 100% the vapour pressure is used (dew). For example, when the Ref Weight parameter is set to 50%, then the controller will use a weighted average of 50% liquid pressure and 50% vapour pressure. Any percentage from 1 to 99% will give an appropriate weighted average between the two pressures. For evaporator control vapour pressure would normally be used so the Ref Weight parameter should be set to 100%. |
| P-32 | Pressure Units | Absolute or Gauge |
| P-33 | Evap Offset | Offset to allow for pressure drop over distance |
| P-34 | Glide | Allows a glide value to be applied for a particular refrigerant mix where the component gases have different boiling points (at the same pressure). |
| P-35 | Trans Span | Total range of the transducer |
| P-36 | Trans Offset | Value below zero |
| P-37 | MOP Cut-in | If the pressure exceeds this value, then the controller's valve will close or be reduced to a predetermined percentage. A MOP alarm is also created. (See Maximum Operating Pressure (MOP)) |



| Number | Parameter | Description |
|--------|------------------------|--|
| P-38 | MOP Diff | When the pressure reduces below this value, the controllers valve will recover to their normal operational |
| P-39 | Mop Delay | Delay after the MOP value has been exceeded before the MOP actions and alarm occurs. |
| P-150 | Custom A1 | For more information regarding the setting up of custom refrigeration, please contact RDM Technical Support. |
| P-151 | Custom B1 Hi | |
| P-152 | Custom B1 Lo | |
| P-153 | Custom C1 | |
| P-154 | Custom A2 | |
| P-155 | Custom B2 Hi | |
| P-156 | Custom B2 Lo | |
| P-157 | Custom C2 | |
| P-121 | Allow SH Offset | Allows for the superheat reference setpoint (P-08) to be offset by +/-12 degrees using a remote command. See Remote Commands . Note: - The controller will only take this command for 10 minutes before reverting back. The incorrect setting of this value may result in flood back causing damage to the pack compressors, do not adjust this parameter if you are unsure of the consequences. |
| dFLt | Restore default values | Restores all of the parameters to their default values |

Load Shedding

Used on CO2 sites for load shedding on CO2 Compressor Faults or CO2 Vessel High Pressure Alarms. Cases can be put into a "CO2 Case Off" mode 1 or mode 2 to reduce the load on the pack or to reduce the CO2 vessel pressure. Mode 1 will open the LLV/EEV and stop the fans, mode 2 will close the LLV/EEV and stop the fans. See: RDM CO2 load shedding user guide.

Superheat Options

The superheat for EEV control can be calculated using different means to suit the application. Selectable from parameter P-17 – Evap Select;

- **Local** - Based on the value of the Evaporator and Suction line temperature probe inputs connected directly to the controller.
- **Rem1** - The local suction line temperature probe and a local suction pressure measured by a transducer connected to the refrigeration case island Mercury Hub (PR0018-PHI) or Intuitive Switch (PR0757/758) **Note: RS232 comms variants only**. The pressure read from the Mercury Hub pressure transducer is converted to a temperature based on the gas type being used by the system. This temperature is transmitted to all controllers connected to the Mercury Hub. **Note:** Broadcast ID (P-30) must be set to 0. See section: [Mercury Switch](#) below.
- **Rem1/2/3**– The local Suction line temperature probe and a remote suction pressure value broadcast by an Intuitive Pack controller on the same IP network. The pressure received from the Intuitive Pack controller is converted to a temperature based on the gas type being used by the system. Using an IP Futura or Mercury Switch. **Note:** Broadcast ID (P-30) must be set to the pack's network ID (rotary address), this method cannot be used when using a PR0018-PHI Hub or PR0757/758 Switch, See section: [Plant Pack Controller](#) below.
- **Trans V / Trans mA / Cust V / Cust mA**– The local suction line temperature probe and a local suction pressure measured by a transducer connected to the controller's internal transducer input and converted to evaporator temperature. See section: [Local Analogue Input](#) below.



EEV Control Using Pressure

There are several ways to use the suction pressure to calculate the evaporator in temperature;

Mercury Switch (PR0018-PHI) or Intuitive Switch (PR0757/758)

(P-17 set to Rem1)

The Mercury Switch can be used for EEV control on an Island by island basis. A suction pressure transducer is connected from the case Island to the 4-20mA input of the Mercury Switch and the pressure read from this transducer is converted to a temperature based on the gas type being used by the system. This temperature is transmitted to each controller connected to the switch and along with the suction temperature probe, local to the controller, the superheat is calculated. Please note that RDM recommended that the evaporator in temperature probe is fitted as the controller will use this to calculate the superheat in the event of a communication loss with the Mercury Switch. P-17 allows for the use of this remote temperature provided by the Mercury Switch. Please see the Mercury Switch or Intuitive Switch user document for further details. **Note: RS232 comms variants only**

Remote pressure from a networked RDM Pack Controller

(P-17 set to Rem1/ Rem2/ Rem3)

(P-30 set to network ID of Plant Pack)

(P-31 set to refrigerant type)

P-17 is set depending on which input the suction transducer is connected to on the plant controller (Transducer input 1, 2 or 3). The broadcast ID (P-30) should be set to the network ID of Plant Pack Controller (Rotary Switch Setting). The Refrigerant type (P-31) must be set along with pressure units (P-32) set to Absolute or Gauge. This method cannot be used when using a PR0018-PHI Hub or PR0757/758 Switch.

Local Analogue Input – mA or V

(P17 set to Trans mA / Trans V / Cust V / Cust mA)

(P-31 to P-36 must be set accordingly)

A suction transducer can be connected directly to the analogue input of the controller (See I/O Connections of the [Mercury](#) and [Intuitive Mercury](#)). The controller will calculate the evaporator temperature from the suction pressure, and along with the suction temperature probe local to the controller, the superheat is calculated. Please note that RDM recommend that the evaporator in temperature probe is fitted as the controller will use this to calculate the superheat in the event of a transducer fault.

Maximum Operating Pressure (MOP)

If the controller is set to use a local or remote pressure transducer to calculate the suction temperature, then a MOP alarm can be generated (using parameters (P-37/P-38/P-39). When a MOP alarm is generated on the controller, it will either close or reduce the EEV valve opening when a predetermined pressure is reached. This MOP value is configured in the Mercury controller. When the MOP alarm is generated, the controller reduces the maximum valve opening to this percentage. For example if the "EEV Divide Value" parameter is set to 50% and the MOP alarm is generated then the maximum valve opening will be limited to 50%. For M controllers the LLV is closed for the MOP alarm duration. The alarm LED on the display will also appear in this state.

Ref Weighting

When using a local pressure transducer to calculate superheat, the Mercury controller can use a weighted average of liquid pressure and vapour pressure to calculate the temperature. For example, when the Ref Weight parameter is set to 50%, then the controller will use a weighted average of 50% liquid pressure and 50% vapour pressure. Any percentage from 1 to 99% will give an appropriate weighted average between the two pressures. For evaporator control vapour pressure would normally be used so the Ref Weight parameter should be set to 100%

Valve Control Type

The controller has three methods of valve control selectable using P-11.



EEV

This is the default method and most commonly used. The control temperature (air on and air off average) is used to start the valve operation, when the temperature rises above the cut in temp parameter (P-01) the valve will switch on and open to its start opening value (P-56) for 30 seconds to establish a superheat reading, valve state will show "Start".

After 30 seconds the valve state will change to "Run" and valve opening is controlled according to the superheat value referenced to the superheat target parameter (P-08). Generally speaking if the superheat value is higher than the target (P-08, default 6 degrees) then the valve will open, if the superheat is below target then the valve will start to close.

As a safety feature to prevent liquid flood back, if the superheat drops too low (below the superheat problem setting P-52, default 0 degrees) for a period longer than the problem time (P-54, default 3 minutes) then the valve will close to the problem opening value (P-53, default 10%) for the superheat problem time (P-54), valve state will show "Problem". After the valve problem opening period has expired, the valve will go through the normal "Start" and "Run" process as detailed above. If the superheat value still remains low after another problem time period then the valve will re-enter the problem state and the process will be repeated.

If at any point the control temperature (air on and air off average) drops below the cut in parameter (P-01) minus the diff (P-02), the valve will be switched off and closed fully. Once the control temperature rises above the setpoint again (P-01), the valve will start up again and the above procedure will be repeated.

In summary, the control temperature (air on air off average) acts as a thermostat to switch the valve on and off, once switched on the valve will control to the superheat target.

EET

This method uses the control temperature (air on and air off average) to control the valve around the cut in set point (P-01). If the control temperature is above setpoint then the valve will start opening and if below setpoint the valve will start closing, the further away the temperature is from setpoint the faster the valve will open and close.

As a safety feature the superheat will still be monitored but will only take control of the valve if the superheat drops below the superheat problem value and will then enter the "problem", "start" and "run" sequences as detailed above. Once the superheat has recovered valve control will pass back to the air on and air off probes.

EEV/EET

This method uses a combination of EEV and EET control detailed above. The control temperature (air on/air off average) will control the valve around the cut in setpoint (P-01). At the same time the superheat is monitored and if this gets close to the superheat target (P-08) then valve control will pass to the superheat value referenced against the superheat target. Control will switch between superheat and air on/air off temperature control and will attempt to maintain the superheat target (P-08) and the control temperature (P-01) alternatively.

Relay State and functional operation

| Relay 1-3 State | Function State | Wired contact | Relay 4-5 State | Function State | Wired contact |
|-----------------|---------------------|---------------|-----------------|---------------------|---------------|
| Relay 1 off | Valve / Comp. A on | N/C | Relay 4 off | Suction Valve on | N/C |
| Relay 1 on | Valve / Comp. A off | N/C | Relay 4 on | Suction Valve off | N/C |
| Relay 2 off | Fans on | N/C | Relay 4 off | Trims off | N/O |
| Relay 2 on | Fans off | N/C | Relay 4 on | Trims on | N/O |
| Relay 3 off | Lights on | N/C | Relay 4 off | Alarm Relay = Alarm | N/C |
| Relay 3 on | Lights off | N/C | Relay 4 on | Alarm Relay = OK | N/C |
| Relay 3 off | Alarm Relay = Alarm | N/C | Relay 4 off | Compressor B off | N/O |
| Relay 3 on | Alarm Relay = OK | N/C | Relay 4 on | Compressor B on | N/O |
| | | | Relay 5 off | Defrost control off | N/O |
| | | | Relay 5 on | Defrost control on | N/O |

Normally open (N/O) and normally closed (N/C) contacts refer to the relay contacts that are fed from the common connection when the controller is unpowered. Items connected to the N/C contact, such as fans and LLV, will remain on if the controller loses power. Items connected to the N/O contact, such as defrost and trim heaters, will switch off if the controller loses power.



Relay and screen states during defrost

| State: | Pump Down | Defrost Min | Defrost Max | Drain Down | Fan Delay | Recovery |
|----------------------------------|-----------|-------------|-------------|------------|-----------|----------|
| Screen: | DEF | DEF | DEF | DEF | DEF | REC |
| Def LED: | On | On | On | Off | Off | Off |
| RLY 1 LLV | Closed | Closed | Closed | Closed | Open | Open |
| RLY 4 Suction Line | Off | On | On | On | Off | Off |
| RLY 4 Trim on in defrost | On | On | On | On | On | On |
| RLY 4 Trim off in defrost | Off | Off | Off | Off | Off | On |
| RLY 5 Defrost Relay | Off | On | On | Off | Off | Off |
| RLY 3 Lights relay | On | On | On | On | On | On |
| RLY 2 Fans (On in DF) | On | On | On | On | Off | On |
| RLY 2 Fans (Off in DF) | On | Off | Off | Off | Off | On |

Defrost Type (P-91)

If P-91 is set to Gas, compressor 1 is switched on for the duration of the defrost cycle. If set to Gas 2, both compressors are switched on for the duration of the defrost cycle

Defrost Termination

Defrost termination will be when the temperature parameter "def terminate" has been reached on the "defrost termination" probe. If the "defrost termination" probe is not fitted, defrost termination will occur when: -

- The "coil in" probe reaches the set point (If fans are selected as "off during defrost")
- Or The "air off" probe reaches the set point (If fans are selected as "on during defrost")

If the "coil in" probe is not fitted, the "air off" probe will be used. If the "air off" probe is faulty termination will occur when the time-out period has elapsed.

Fan Delay after Defrost

The fans will come back on when: -

- The fan delay time has elapsed if the "fan delay mode" is set to time
- Or If the fan delay mode is set to "temp", the fans will come on when the defrost termination probe reaches the fan delay set point, or on the time parameter, whichever occurs first.

If the "defrost termination" probe is not fitted, the fans will come on when: -

- The "coil in" probe reaches the control set point (If fans are selected as "off during defrost")
- Or The "air off" probe reaches the control set point (If fans are selected as "on during defrost")

Network Configuration

The final section to setup is the network address. In all instances, this must be done before the controller is plugged into the site network.

For the Mercury there are two standard hardware variants; [RS232](#) interface or built in [IP](#) (See [Ordering details](#) for more information).

When using an Intuitive Mercury controller, the controller has to have the correct network card fitted (see [compatible network interfaces](#)). For connection to a Mercury Switch (Hub) or an IP Futura network interface, the standard fitment RS232 network card is utilised.

Mercury RS232 Variant & Intuitive Mercury

When logging a Mercury with an RS232 interface onto a network you must first connect the controller to a communications module, this is either a 485 Legacy, IP Futura, Mercury Switch or Bluetooth network module.



IP Futura module & Intuitive Internal IP Network card

In an IP system there are two options;

- IP-L – setting rotary address of module to 000
- IP-r – setting rotary address of module to a unique number that is not 000

IP-L allows the user to statically assign an IP address in the controller which could be used, for example, when connecting the controllers onto a customer's local area network that does not use DHCP.

IP-r allows the network ID (rotary switch address) to be used by a system running a DHCP server (for example the RDM Data Manager) to issue out an IP address automatically.

IP-L

To configure the communication module or network card for IP-L, set all three rotary switches to zero. The module should then be connected to the controller. In the case of an Intuitive Mercury controller where the network card is already fitted, the controller should be powered off, all three rotary switches set to zero and the controller powered on.

- From within the device's display navigate to the 'nEt' menu and press the 'enter' key.
- 'IP-L' will be displayed, press enter again.
- The user can now set the address using the table below

| Display | Option |
|---------|--|
| IP-1 | IP Address byte 1 |
| IP-2 | IP Address byte 2 |
| IP-3 | IP Address byte 3 |
| IP-4 | IP Address byte 4 |
| nL | Network Mask Length (see the network mask length table above) |
| gt-1 | Gateway Address byte 1 |
| gt-2 | Gateway Address byte 2 |
| gt-3 | Gateway Address byte 3 |
| gt-4 | Gateway Address byte 4 |
| ESC | Exit network menu. Note: This option must be selected to save any changes made in this menu. |

To ease setup, a single network mask length value is used. If the address has been specified with a network mask value in dotted IP format e.g. 255.255.255.0 then the table below gives the conversion:

| Mask | Length | Mask | Length | Mask | Length |
|-----------------|--------|---------------|--------|-------------|--------|
| | | 255.255.254.0 | 23 | 255.254.0.0 | 15 |
| 255.255.255.252 | 30 | 255.255.252.0 | 22 | 255.252.0.0 | 14 |
| 255.255.255.248 | 29 | 255.255.248.0 | 21 | 255.248.0.0 | 13 |
| 255.255.255.240 | 28 | 255.255.240.0 | 20 | 255.240.0.0 | 12 |
| 255.255.255.224 | 27 | 255.255.224.0 | 19 | 255.224.0.0 | 11 |
| 255.255.255.192 | 26 | 255.255.192.0 | 18 | 255.192.0.0 | 10 |
| 255.255.255.128 | 25 | 255.255.128.0 | 17 | 255.128.0.0 | 09 |
| 255.255.255.0 | 24 | 255.255.0.0 | 16 | 255.0.0.0 | 08 |

IP-r

To configure the communication module for IP-r, set the three rotary switches to give each controller a unique identifier. The module should then be connected to the controller and the network. In the case of an Intuitive Mercury controller where the network card is already fitted, the three rotary switches must be set when the controller is powered off, then power up before connecting to the network. To view the issued IP address from the DHCP server;

- Select 'nEt' from the function menu and press the 'Enter' key.
- 'IP-r' will be shown, press enter again
- Similar to the [tables](#) above, the network details can be viewed.

Mercury Switch

A similar process to that of the [IP Futura](#) can be used with the Mercury Switch. Please refer to the Mercury Switch user guide, which can be obtained from the RDM website, for information regarding connecting a controller to a network.



Bluetooth Network module

Connecting a Bluetooth Network Module to the controller will update the screens available under the 'Net' menu. They are detailed below;

| Display | Option |
|---------|---|
| 485t | 1: 485 Genus Network (See RS485 module/ Intuitive Internal RS485 Network card) 2: Bluetooth |
| 485A | Bluetooth device name. As it will appear on DMTouch's device list (RC00-0 – RC99-9) |
| nI d | Select Bluetooth Network ID (0 – 4) |
| gAdd | Shows underlying network address assigned to controller |
| rLog | Re-log the controller back onto the network |
| ClrA | Clear the address/ name from the controller |
| ESC | Exit network menu. Note: this option must be selected to save any changes made in this menu. |

- Ensure the 485t is set to '2' (Bluetooth)
- Provide a unique device alias under the 485A menu (e.g. 01-5)
- Select the Network ID. Please see the Bluetooth wireless mesh setup guide for more details.
- Press the 'ESC' to save

The green network LED will flash to show it is attempting to log on and go solid when connected.

RS485 module/ Intuitive Internal RS485 Network card

Connecting an RS485 legacy Module or an Intuitive Internal RS485 network card to the controller will govern which set up screens available under the 'Net' menu. Both modules support the Genus protocol only. They are detailed below;

| Display | Option |
|---------|---|
| 485t | 1: 485 Genus Network 2: Bluetooth (See Bluetooth Network module) |
| 485A | RS485 device name. As it will appear on DMTouch's device list (RC00-0 – RC99-9) |
| gAdd | Shows underlying network address assigned to controller |
| rLog | Re-log the controller back onto the network |
| ClrA | Clear the address/ name from the controller |
| ESC | Exit network menu. Note: this option must be selected to save any changes made in this menu. |

- Ensure the 485t is set to '1' (Genus RS485)
- Provide a unique device alias under the 485A menu (e.g. 01-5)
- Press the 'ESC' to save

The green network LED will flash to show it is attempting to log on and go solid when connected.

Mercury IP Variant

When logging a Mercury with an in-built IP interface it be connected directly into an IP network without the need of a communications module.

When networking the Ethernet variant, the 'Net' menu will have the following menus:

| Display | Option |
|-------------|---|
| IP-L / IP-r | Read/ Write Static IP address / Read Only DHCP IP address |
| Id | The 3 digit network address |
| AtyP | IP-r / IP-L selection |
| ESC | Exit Menu |

Similar to the [IP Futura setup](#), IP-L allows you to fix a static IP address into the controller and IP-r allows you to give each controller on the system a unique network number (using the Id).

- To firstly select between IP-L and IP-r navigate to 'AtyP'.

IP-r

Once IP-r is selected the controller must be given a unique 3 digit 'network address' that no other device on the network has (**note** if logging on to a Data Manager, this will be the device ID). Once the ID has been set connect the controller to the IP network for it then to be given an IP address by the DHCP server. To view the IP address given, within the Net menu, navigate to 'IP-r'.



IP-L

If IP-L has been selected from the 'AtyP' menu the IP address must be set in the controller by navigating to 'IP-L' within the 'Net' menu. The following menus will be available:

| Display | Option |
|---------|--|
| IP-1 | IP Address byte 1 |
| IP-2 | IP Address byte 2 |
| IP-3 | IP Address byte 3 |
| IP-4 | IP Address byte 4 |
| nL | Network Mask Length (see the network mask length table above) |
| gt-1 | Gateway Address byte 1 |
| gt-2 | Gateway Address byte 2 |
| gt-3 | Gateway Address byte 3 |
| gt-4 | Gateway Address byte 4 |
| ESC | Exit network menu. N.B. this option must be selected to save any changes made in this menu |

Once the IP address has been entered, the controller can be connected to the IP network.

Viewing IO

Apart from setting up the controller, you can also view the status of the inputs and outputs and controller states.

From the function menu, select "I/O", press enter. You can now scroll through the IO table as set out below. Inputs and outputs that do not apply to a particular controller type will be greyed out.

Input / Output Table

| Number | IO | Range* °C (°F) | Step | Units | M Type 1&2 | M Type 3&4 | M Type 5&6 | E Type 3&4 | E Type 5&6 |
|--------|-------------------------------------|---------------------------|------|-------|------------------|------------------|------------------|------------------|------------------|
| I-01 | Control Temp. | -42 to 128 (-43.6 to 262) | 0.1 | Deg | ✓ | ✓ | ✓ | ✓ | ✓ |
| I-02 | Display temp. | -42 to 128 (-43.6 to 262) | 0.1 | Deg | ✓ | ✓ | ✓ | ✓ | ✓ |
| I-03 | Air on Probe | -49 to 128 (-56.2 to 262) | 0.1 | Deg | ✓ | ✓ | ✓ | ✓ | ✓ |
| I-04 | Air off Probe | -49 to 128 (-56.2 to 262) | 0.1 | Deg | ✓ | ✓ | ✓ | ✓ | ✓ |
| I-05 | Evaporator Probe | -42 to 128 (-43.6 to 262) | 0.1 | Deg | ✓ | ✓ | ✓ | ✓ | ✓ |
| I-06 | Suction Line Probe | -42 to 128 (-43.6 to 262) | 0.1 | Deg | ✓ | ✓ | ✓ | ✓ | ✓ |
| I-07 | Superheat | -30 to 60 (-54 to 108) | 0.1 | Deg | ✓ | ✓ | ✓ | ✓ | ✓ |
| I-08 | Logging Probe | -49 to 128 (-56.2 to 262) | 0.1 | Deg | ✓ | ✓ | ✓ | ✓ | ✓ |
| I-09 | Defrost Probe | -49 to 128 (-56.2 to 262) | 0.1 | Deg | ✓ | ✓ | ✓ | ✓ | ✓ |
| I-10 | Alarm Temp | -49 to 128 (-56.2 to 262) | 0.1 | Deg | ✓ | ✓ | ✓ | ✓ | ✓ |
| I-11 | Case Clean | 0 (Off), 1 (On) | | | ✓ | ✓ | ✓ | ✓ | ✓ |
| I-12 | Door Sensor | 0 (Closed), 1 (Open) | | | | | ✓ | | ✓ |
| I-13 | Person Trapped | 0 (OK), 1 (Alarm) | | | | | ✓ | | ✓ |
| I-14 | Plant Fault 2 (Integral) | 0 (OK), 1 (Alarm) | | | ✓ | | | | |
| | External Defrost (EEV) | 0 (Off), 1 (On) | | | ✓ | | | ✓ | ✓ |
| I-15 | Monitor Probe | -49 to 128 (-56.2 to 262) | 0.1 | Deg | | ✓ | ✓ | ✓ | ✓ |
| I-16 | Remote Evap Temp | -49 to 128 (-56.2 to 262) | 0.1 | Deg | | | | | |
| I-17 | MOP | 0 (Off), 1 (On) | | | | ✓ | ✓ | ✓ | ✓ |
| I-18 | External Defrost (Mechanical Valve) | 0 (Off), 1 (On) | | | ✓ | ✓ | ✓ | | |
| | Hub Trim Level (EEV) | 0 to 100 | 1.0 | % | | | | ✓ | |
| I-19 | Divide Input | 0 to 100 | 1.0 | % | | | | ✓ | ✓ |
| I-20 | Remote Pressure | -3.4 to 180.0 | 0.1 | Bar | | | | ✓ | ✓ |
| I-21 | Local Pressure | -3.4 to 180.0 | 0.1 | Bar | | | | ✓ | ✓ |
| I-22 | Local Calc temp | -49 to 128 (-56.2 to 262) | 0.1 | Deg | | | | ✓ | ✓ |
| I-25 | Load Shed | 0 (Off), 1 (On) | | | | ✓ | ✓ | ✓ | ✓ |



| Number | IO | Range* °C (°F) | Step | Units | M Type 1&2 | M Type 3&4 | M Type 5&6 | E Type 3&4 | E Type 5&6 |
|--------|---------------------------------|--|-------|-------|------------------|------------------|------------------|------------------|------------------|
| I-30 | Plant Fault 1 | 0 (OK), 1 (Alarm) | | | ✓ | ✓ | ✓ | ✓ | ✓ |
| I-31 | Plant Fault 2 | 0 (OK), 1 (Alarm) | | | ✓ | ✓ | ✓ | ✓ | ✓ |
| I-32 | Plant Fault 3 | 0 (OK), 1 (Alarm) | | | ✓ | ✓ | ✓ | ✓ | ✓ |
| O-01 | Liquid Line Valve | 0 (Off), 1 (On) | | | | ✓ | | | |
| O-02 | Suction Line Valve | 0 (Off), 1 (On) | | | | | ✓ | | ✓ |
| O-03 | Compressor A | 0 (Off), 1 (On) | | | ✓ | | | | |
| O-04 | Compressor B | 0 (Off), 1 (On) | | | ✓ | | | | |
| O-05 | Defrost Control | 0 (Off), 1 (On) | | | ✓ | ✓ | ✓ | ✓ | ✓ |
| O-06 | Lights | 0 (Off), 1 (On) | | | ✓ | ✓ | ✓ | ✓ | ✓ |
| O-07 | Case Fans | 0 (Off), 1 (On) | | | ✓ | ✓ | ✓ | ✓ | ✓ |
| O-09 | EEV Opening | 0 to 100 | 0.1 | % | | | | ✓ | ✓ |
| O-10 | Last Def. Time | 00:00 to 23:59 | | hh:mm | ✓ | ✓ | ✓ | ✓ | ✓ |
| O-11 | Last Def. Length | 00:00 to 03:00 | | hh:mm | ✓ | ✓ | ✓ | ✓ | ✓ |
| O-12 | Last Def. Ctrl Temp. | -42 to 128 (-43.6 to 262) | 0.1 | Deg | ✓ | ✓ | ✓ | ✓ | ✓ |
| O-13 | Last Def. Type | 0 (None), 1 (Internal), 2 (External), 3 (Network), 4 (Display), 5 (Timed) 6 (Forced), 7 (Skipped) | | | ✓ | ✓ | ✓ | ✓ | ✓ |
| O-14 | Suction Line Valve/Trim Heaters | 0 (Open/Off), 1 (Closed/On) | | | | ✓ | | ✓ | |
| O-15 | Alarm Relay 1 (Relay4) | 0 (Unused), 1 (OK), 2 (Alarm) | | | | ✓ | ✓ | ✓ | ✓ |
| O-16 | Alarm Relay 2 (Relay3) | 0 (Unused), 1 (OK), 2 (Alarm) | | | ✓ | ✓ | ✓ | ✓ | ✓ |
| O-17 | Remote Relay (Relay 4) | 0 (Off), 1 (On) | | | ✓ | ✓ | ✓ | ✓ | ✓ |
| O-18 | Run Time | 0 - 128 K Hours | 1 | k hrs | ✓ | ✓ | ✓ | ✓ | ✓ |
| O-20 | Door Open Time | 00:00 to 23:59 | | hh:mm | | | | | ✓ |
| O-21 | Door Open Length | 00:00 to 03:00 | | hh:mm | | | | | ✓ |
| O-30 | Set Point Offset | -49 to 128 (-56.2 to 262) | 0.1 | Deg. | ✓ | ✓ | ✓ | ✓ | ✓ |
| O-31 | Trim Off Period | 00:00 to 05:00 | 00:01 | mm:ss | | ✓ | | ✓ | |
| O-32 | Superheat Offset | -12.0 to 12.0 | | | | | ✓ | ✓ | ✓ |
| S-01 | Control State | 0 (Stabilise),1 (Normal), 2 (Defrost Min),3 (Defrost Max), 4 (Drain Down),5 (Fan Delay), 6 (Recovery),7 (OT Alarm), 8 (UT Alarm),9 (Fans Only), 10 (Lights Only),11 (Case Off),12 (Pump Down),13 (Defrost Hold),14 (Load Shed) | | | ✓ | ✓ | ✓ | ✓ | ✓ |
| S-02 | Valve State | 0 (Off), 1 (Start), 2 (Run), 3 (Problem),4 (Fail), 5 (Shed) | | | | | | | |

* Range is dependent on probe type

Maximum and Minimum Control Temperature

Type M only (Not supported in type E).

To view the maximum or minimum Control Temperature the controller has reached since last power off/on press and hold the Up and Down Buttons together for 3 seconds. The display will show "diSP", press the Up Button to view the maximum Control Temperature the controller has reached or press the Down Button to view the minimum Control Temperature the controller has reached.



Display will revert back to normal operation if the Enter Button is pressed or after 1 minute of no button presses. The top bar of the left hand segment will be lit when the maximum temperature is being displayed. The bottom bar of the left hand segment will be lit when the minimum temperature is being displayed. Resetting the controller will clear out these values.

Display Messages

The following alarms and messages can appear on the Mercury display.

| Display Message | System status | Display Message | System status |
|-----------------|---------------------------|-----------------|-----------------------------|
| Ft | Control Fault | Plt3 | Plant Fault 3 |
| Prb1 | Probe 1 Fault | Plt4 | Plant Fault 4 |
| Prb2 | Probe 2 Fault | FanSONLy | Controller in Fans Only |
| Prb3 | Probe 3 Fault | LitSONLy | Controller in Lights Only |
| Prb4 | Probe 4 Fault | CASE OFF | Controller in Case Off |
| Prb5 | Probe 5 Fault | Ot | Over Temperature Alarm |
| Prb6 | Probe 6 Fault | Ut | Under Temperature Alarm |
| rEC | Control State in Recovery | door | Door Open Alarm |
| dEF | Control Sate in Defrost | TrAP | Person Trapped Alarm |
| AL | Control State in Alarm | LgOt | Log Probe Over Temperature |
| Plt1 | Plant fault 1 | LgUt | Log Probe Under Temperature |
| Plt2 | Plant Fault 2 | | |

Network Alarms

The table below shows the text and associated type number that is sent to the system "front end". The type number is normally used to provide different alarm actions.

| Alarm text | Type # (index) | Alarm text | Type # (index) |
|-----------------------------|----------------|---------------------------|----------------|
| Missed defrost | 15 | Product under temperature | 9 |
| Plant Fault 1,2,3 or 4 | 3 | Person Trapped | 1 |
| Case over temperature | 4 | Monitor Probe OT | 12 |
| Case under temperature | 5 | Case Clean | 29 |
| Probe 1,2,3,4,5 or 6 Faulty | 6 | Remote evap temperature | 6 |
| Door Left Open | 2 | Transducer Fault | 6 |
| Product over temperature | 8 | Load Shedding | 7 |
| MOP Alarm | 3 | Lights Only | 29 |

Modifying controller states

During normal operation you can change the following states from the function menu

Fans Only "FanS"

Selecting the Fans Only option will put the controller into the Fans Only state if the current state is not Fans Only. If the current state is Fans Only then the controller will change to the Normal state. Selecting this option will exit the setup menu automatically. The display will show "FanSONLy"

If a remote display with key switch is being used, this function can be invoked by turning the key switch to the fans only position (90 degrees clockwise) with parameter P85 set to "fans".

Case Off "CASE"

Selecting the Case Off option will put the controller into the Case Off state if the current state is not Case Off. If the current state is Case Off then the controller will change to the Normal state. Selecting this option will exit the setup menu automatically. The display will show "CASE OFF". An alarm is generated, fixed delay of 1 minute, when the controller is placed into the Case Off state.



If a remote display with key switch is being used, this function can be invoked by turning the key switch to the case-off position. (Clockwise 90 degrees) with parameter P85 set to "case".

Lights Only "Ligt"

Selecting the Lights Only option will put the controller into the Lights Only state if the current state is not Lights Only. If the current state is Lights Only then the controller will change to the Normal state. Selecting this option will exit the setup menu automatically. The display will show "LitSOOnLy". An alarm is generated, fixed delay of 1 minute, when the controller is placed into the Lights Only state.

Note. When lights are being used in "Remote" mode with a timing channel: -

If the controller goes offline, the lights are turned ON after a delay of 5 minutes. The lights will stay on until the controller comes back on-line where they will revert to the state of the timing channel being used.

Probe Offset

This feature allows each probe value to be modified by an "offset". Offset values are from -10°C (-18°F) to +10°C (+18°F) and on a channel basis. Example C1 = Probe 1.



Remote Commands

The following commands can be used by a Data Builder program:-

| Command | Value to send | Description | Conditions |
|-------------------|------------------|---|--|
| Defrost Command | 1 | Initiates a defrost cycle | Defrost mode: remote |
| Defrost Command | 3 | Terminates the defrost | Defrost mode: remote Defrost hold: On Defrost min state complete |
| Trim Command | 0 to 100% | Sets the trim level to this value (Trim period is 5 min) | Relay 4 mode: Trim Heater |
| Setpoint Command | +/-18 | Is added to or subtracted from the setpoint | |
| Case Off Command | 5 6 8 0 | Sets the controller to Case Off Sets the controller to Fans Only Sets the controller to Lights Only Restores the controller from Case Off to Normal | |
| Haccp Command | 0 1 2 | HACCP LED OFF HACCP LED On HACCP LED Flashes | |
| Button Command | 0 1 | Buttons backlights Off Buttons backlights On | |
| EEV Command | 2 1 | Shuts the valve off Restores the valve to normal operation | |
| Divider Command | 0 to 100% | Sets the maximum valve opening to this percentage. | MOP input from Merc PHI hub must be 'Off'. |
| Superheat Command | +/-12 | Is added to or subtracted from the Superheat reference target (P-08). Adding a negative offset will reduce the Superheat reference and will generally cause the valve to open more. | P-121 "Allow SH Offset" must be set to ON |

Use an "Analogue Out" block configured to the controller name and in the value field type in the command you require. Use a "Setting block" as the input to the "Analogue Out" block to send the Value.

See Example on the right, which sets the Trim Heater on BY10-1 at 40%.

Set Block 1

Name: Trim Level

Type: Analog Internal

Settings

Value: 40

Min: 0

Max: 100

Units: %

OK Cancel

Java Applet Window



Command

Name: Remote Trim

Units: % Internal

Output Mapping

Type: Network

Device: BY10-1

Value: Trim Command

Note: Fixed outputs are only selectable if they do not conflict with DM / DD settings and are not being used by another IO block

OK Cancel

Java Applet Window



Specification

| | Mercury Case Controller PR0740 CAS | Intuitive Mercury Case Controller PR075X & PR076X |
|--|--|--|
| Power requirements | | |
| Supply Voltage Range | 100 – 240 Vac \pm 10% | 100 – 240 Vac \pm 10% |
| Supply Frequency | 50 – 60 Hz | 50 – 60 Hz |
| Maximum supply current | 5.2 Amps (when relay 5 is fully loaded) | 2 Amps |
| Typical supply current | <1 Amp | <1 Amp |
| General | | |
| Operating temperature range | -10°C to 55°C (14°F to 131°F) | -10°C to +60°C (14°F to 140°F) |
| Storage temperature range | -20°C to 65°C (-4°F to 149°F) | -20°C to +65°C (-4°F to 149°F) |
| Environmental | Indoor use at altitudes up to 2000m (6562ft), pollution degree 1, installation category II. Voltage fluctuations not to exceed \pm 10% of nominal voltage. | Indoor use at altitudes up to 2000m (6562ft), pollution degree 1, installation category II. Voltage fluctuations not to exceed \pm 10% of nominal voltage. |
| Size | 78mm(W) x 36mm(H) x 110mm(D) 3.1"(W) x 1.42"(H) x 4.3"(D) | 157mm (W) x 67mm (H) x 120 (D) 6.2"(W) x 2.6"(H) x 4.7"(D) |
| Approx. Weight | 177 grams (6.2 oz) | 500 grams (17.6 oz) |
| Safety | EN60730 | EN60730 |
| EMC | EN61326; 2013 | EN61326; 1997 +Amdt. A1; 1998 |
| Ventilation | There is no requirement for forced cooling ventilation | There is no requirement for forced cooling ventilation |
| Class 2 Insulation | No protective Earth is required and none should be fitted | No protective Earth is required and none should be fitted |
| Supply Fuse | The host equipment must provide a suitable external over-current protection device such as: - Fuse: 2A 240 Vac Anti-surge (T) HRC conforming to IEC 60127 | Built in fuse holder, fuse 2A 240Vac Anti-surge (T) HRC conforming to IEC60127, 32 x 6.3mm (1.26" x 0.25") |
| Or MCB | 2A, 240 VAC Type C conforming to BS EN 60898 | 2A, 240 VAC Type C conforming to BS EN 60898. Note: device has integral 2A fuse |
| Relay Fuse | Not Fitted | 10A 240Vac Anti-surge (T) HRC conforming to IEC60127, 32 x 6.3mm (1.26" x 0.25") |
| Relay Specification | | |
| | Relay 1 – 4 (M) Mechanical Type | Relays 1 – 5 (M) Mechanical Type |
| Max current | 6A Resistive (Cos ϕ = 1) 2A Inductive (Cos ϕ = 0.4) | 10A Resistive (Cos ϕ = 1) 3A Inductive (Cos ϕ = 0.4) |
| Max voltage | 250Vac, 30V dc | 250Vac, 30V dc |
| Relay Fuse | N/A | 10A 240Vac Anti-surge (T) HRC conforming to IEC60127, 32 x 6.3mm (1.26" x 0.25") |
| | Relay 1 Solid State (Type E) | Relay 1 Solid State (Type E) |
| Max Current | 1.0A | 1.0A |
| Max Voltage | 250vac (ac only, will not switch dc) | 250vac (ac only, will not switch dc) |
| | Relay 5 | |
| Max current | 3A Resistive (Cos ϕ = 1) 2A Inductive load (Cos ϕ = 0.4) for 200,000 operations | |
| Max voltage | 250Vac, 30V dc | |
| For compliance with the LVD, relays 3, 4 and 5 commons must be at the same potential as the supply voltage | | |
| Inputs | | |
| Probe Input resistance | 3.01K Ohms (for PTC or NTC type probes) | 3.01K Ohms (for PTC or NTC type probes) |
| Probe Input type | Selectable. See: Units | Selectable. See: Units |
| Digital Inputs | Volt Free | Volt Free |
| Transducer Input mA | 4-20mA current loop powered by | Accuracy +/- 0.5mA |



| | | |
|--------------------|---------------------------------|--------------------------------|
| | 12vdc supply terminal provided. | |
| Transducer Input V | 0-10V dc signal. | Transducer powered externally. |
| Comms | | |
| Serial Variant | RS232 with flow control | RS232 with flow control |
| Ethernet Variant | IP comms | IP comms |

Switched Resistor Example Wiring

Example of resistor fitted on a probe input.

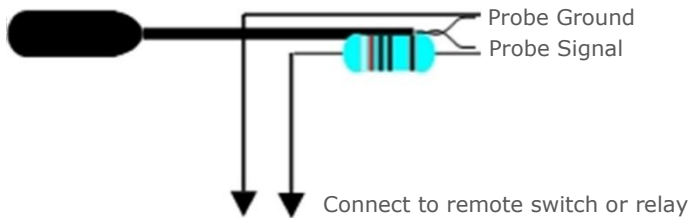

Installation & Dimensions

Panel Cut-out and Clearances

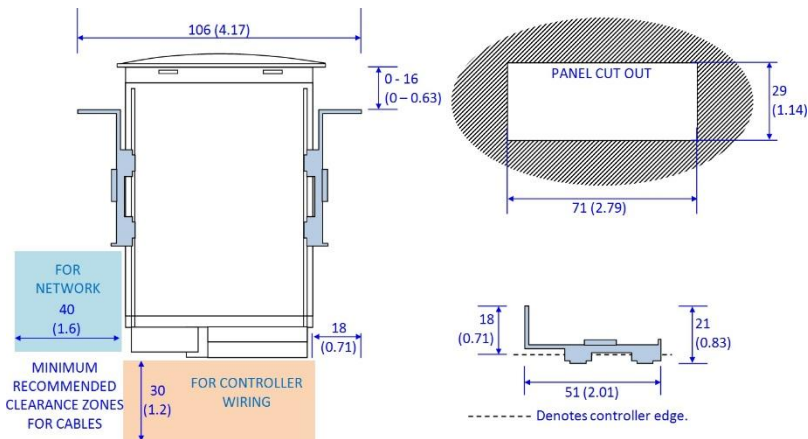

Fixing

The controller is fixed by sliding the 2 plastic retaining clips up to rear of the panel. These clips have a ratchet action and can be removed by holding in the clip sides and sliding back.

There is no requirement for forced cooling ventilation



Dimensions – Mercury

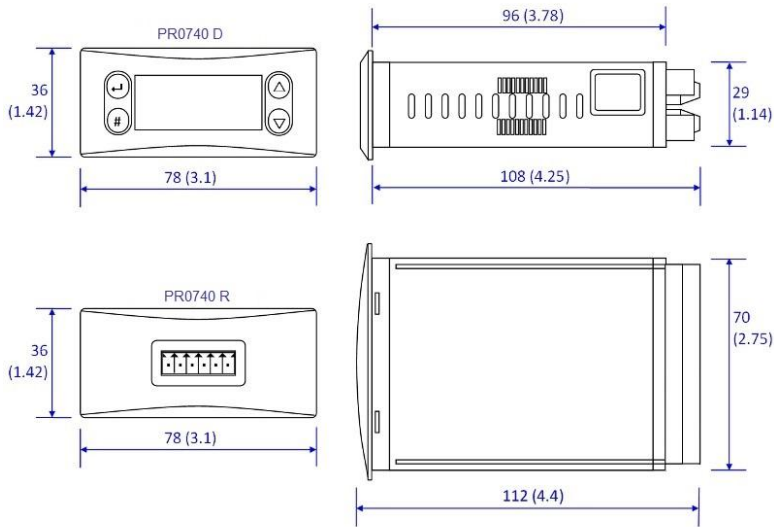

Dimensions – Intuitive Mercury Controller

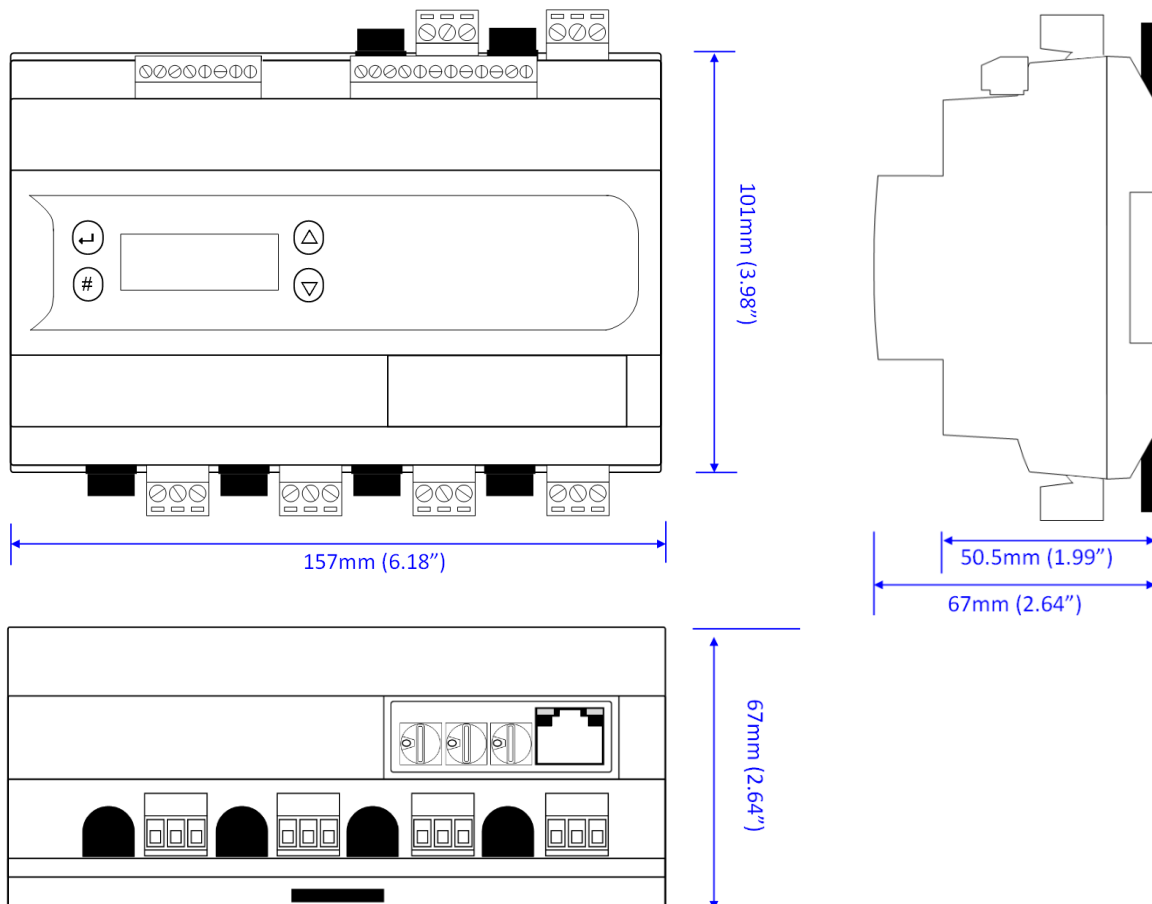

Intuitive Mercury Mounting Instructions

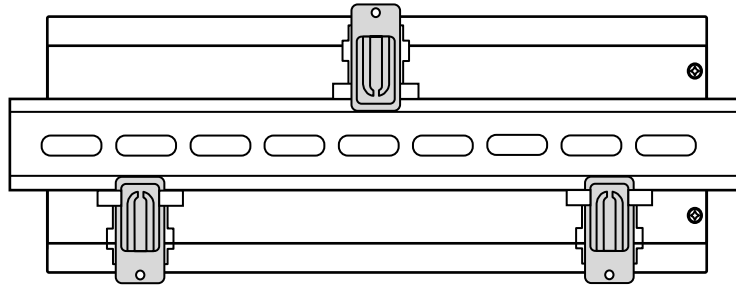

Three clips fix the Intuitive Mercury securely to DIN rail. Pull each clip until it “clicks” to remove the controller. Each clip has a mounting hole to provide an alternative fixing mechanism to DIN mounting.

Cleaning

Do not wet the controller when cleaning. Clean the front by wiping with slightly dampened lint free cloth.

Appendix 1: Defrost Cycles

Fans On in Defrost

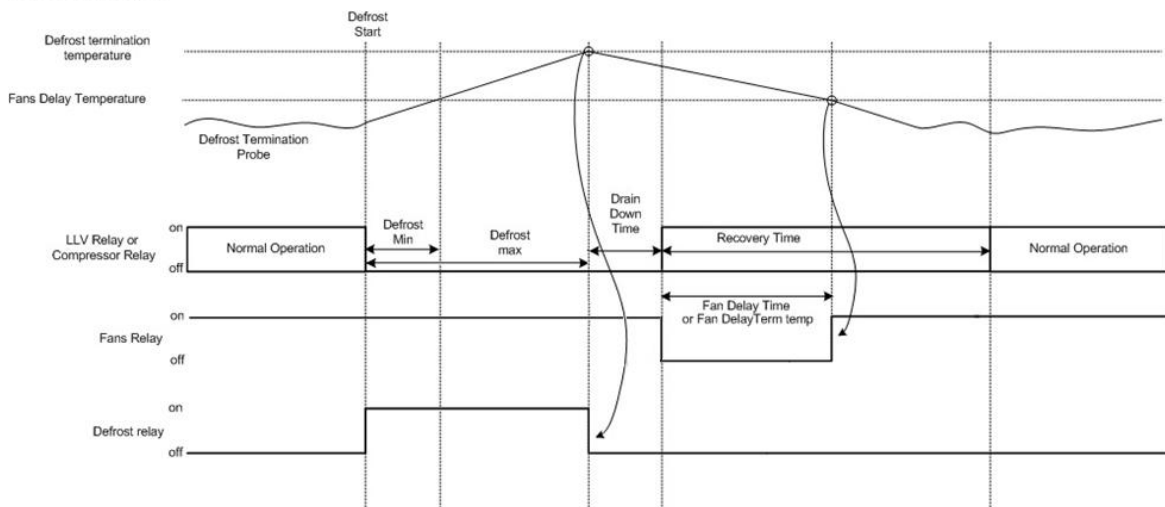

Fans Off in Defrost

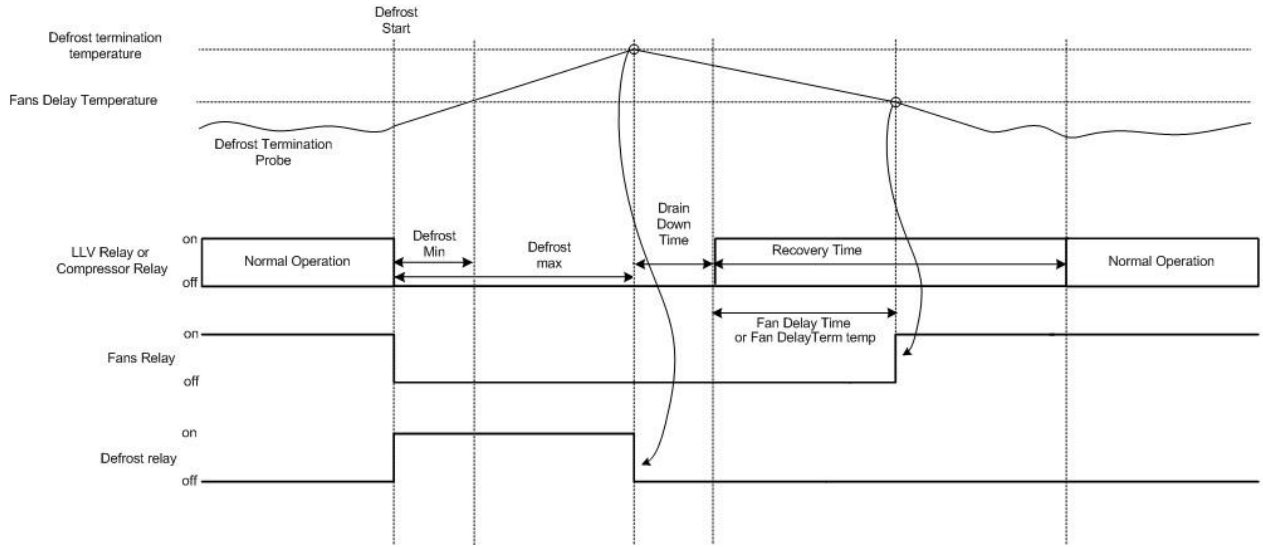

Appendix 2: Trim Heater Control via Mercury/ Intuitive Range

Energy savings via the RDM's range of case controllers can be achieved in a number of ways. One of which is pulsing the trim heater relay off for a given period of time. One way to pulse the trim heater is by configuring P-14. For greater energy savings the Data Manager Energy feature trim control or the Mercury Switch trim control feature can be used. These two options pulse the trim relay dependant on the actual shop floor humidity levels, if the shop floor humidity is relatively low the trim heaters can be pulsed off for longer durations. Please see the relevant user guides for further details.

Due to the high switching rate, trim heaters must not be switched directly from the Mercury trim heater relay and a Trim Heater Pulse Module (PR0723) must be used in all instances of trim control. This module is fitted in between the trim heater of the case and the relay output of the Controller which is pulsing the heater. The trim heater module output provides a smoother power distribution, compared to using the relay output directly, as it switches at the zero voltage crossover point. Switching the trim heater on and off via a normal relay, without using the RDM trim heater pulse module, may damage the trim heater and reduce the operational life of the heater.

Please see the Trim Heater Pulse Module user guide for further details.

Appendix 3: Webpage Appearance

It is possible to view the controller across an IP connection using one of the methods outlined in the [Network Configuration](#) section.

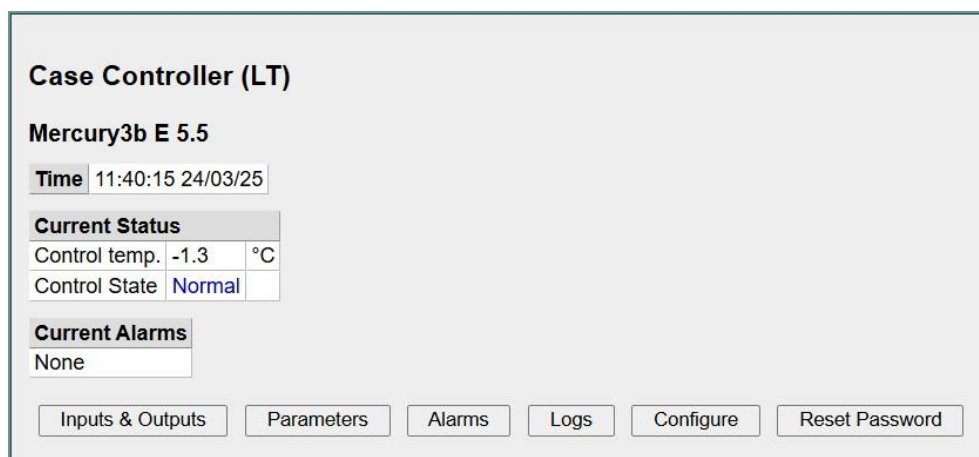

The following screens are samples of how values and settings appear when viewed through a PC/Laptop connection.

The user has a choice of entering the following pages: - **Inputs & Outputs, Parameters, Alarms, Logs & Configure.**

The **Reset Password** menu will only appear initially if a passcode has not been set into the controller or the controller was manufactured before April 2025.



Inputs & Outputs

| Inputs & Outputs | | | | | |
|------------------|---------|------------------|--------|---------------|--------|
| Inputs | | Outputs | | States | |
| Control temp. | -1.4 °C | Valve Opening | 50.0 % | Control State | Normal |
| Display temp. | -1.4 °C | Liq. Line Valve | Open | Valve State | Start |
| Air on Probe | -1.3 °C | Suc.Line/Trims | Off | | |
| Air off Probe | -1.4 °C | Defrost Control | Off | | |
| Evaporator Probe | -1.4 °C | Lights | On | | |
| Suc. Line Probe | 4.3 °C | Case Fans | On | | |
| Superheat | 5.7 °C | Last Def. Time | 09:22 | hh:mm | |
| Logging Probe | N/A °C | Last Def. Length | 00:02 | hh:mm | |
| Defrost Probe | N/A °C | Last Def. Temp. | -1.4 | °C | |
| Alarm temp. | -1.4 °C | Last Def. Type | Timed | | |
| Plant Fault 1 | OK | Setpoint Offset | N/A | °C | |
| Plant Fault 2 | OK | Trim Off Period | 00:00 | mm:ss | |
| Plant Fault 3 | OK | Alm Relay 1 | Unused | | |
| Case Clean | Off | Alm Relay 2 | Unused | | |
| Monitor Probe | N/A °C | Remote Rly4 | Off | | |
| Rem Evap Temp | N/A °C | Run Time | 1 | K Hrs | |
| Ext Defrost | On | Superheat Offset | N/A | °C | |
| MOP | Off | | | | |
| Hub Trim Level | N/A % | | | | |
| Div Input | N/A % | | | | |
| Remote Press | N/A bar | | | | |
| Local Press | N/A bar | | | | |
| Local Calc Temp | N/A °C | | | | |
| Load Shed | Off | | | | |

This is view only screen and shows the states of the inputs and outputs.

Parameters

| Parameters | | |
|--|----------|-------|
| Control EEV Alarms Defrost Lights Pressure | | |
| Parameter Name | Value | Units |
| Cut-in temp | -15.0 | °C |
| Cut-in diff. | 0.0 | °C |
| Control weight | 50 | % |
| Display weight | 50 | % |
| Alarm weight | 0 | % |
| Response On | 10 | |
| Response Off | 10 | |
| Relay 4 Mode | Suc.Line | |
| Trim in Defrost | Off | |
| Trim Level | 100 | % |
| Key Switch | KeyOff | |
| Ctrl Probe Type | Air On | |
| Resistor Case Off | Off | |
| Fans Temp Mode | Off | |
| Fans Off Temp | -10.0 | °C |
| Fan Control | Run | |
| Fan Pulse On | 05:00 | mm:ss |
| Fan Pulse Off | 30:00 | mm:ss |
| Probe 5 Select | Defrost | |
| Relay 3 Mode | Lights | |
| Prb1 Resistor | Plnt3 NO | |
| Service Time | 60 | K Hrs |
| Switch Resistors | On | |
| Lights CaseOff | Unused | |
| Load Shedding | Off | |
| Digital 1 Mode | Defrost | |
| Digital 2 Mode | Case Swt | |
| Cut-in Offset | 5.0 | °C |

This is a view only screen and shows the parameter settings.



Alarms

| Alarms | | |
|----------------|-------------------|-------------------|
| Reason | Occurred | Cleared |
| Probe Fault 1 | 09:37:03 27/03/25 | |
| Probe Fault 2 | 09:34:56 27/03/25 | 09:35:47 27/03/25 |
| Probe Fault 1 | 09:34:55 27/03/25 | 09:35:20 27/03/25 |
| Plant Fault 2 | 09:33:59 27/03/25 | 09:36:24 27/03/25 |
| Plant Fault 1 | 09:33:09 27/03/25 | 09:33:49 27/03/25 |
| Probe Fault 4 | 09:32:46 27/03/25 | 09:34:37 27/03/25 |
| Missed defrost | 23:31:17 24/03/25 | 09:22:00 27/03/25 |

This is a view only screen.

Logs

| Logs | | | | | | | | |
|------------------|----------------------|----------------------|----------------------|----------------------|----------------------|----------------------|----------------------|----------------------|
| | 08:57:25 27/03/25 | 08:57:30 27/03/25 | 08:57:35 27/03/25 | 08:57:40 27/03/25 | 08:57:45 27/03/25 | 08:57:50 27/03/25 | 08:57:55 27/03/25 | 08:58:00 27/03/25 |
| Control temp. | -1.4 | -1.4 | -1.4 | -1.4 | -1.4 | -1.4 | -1.4 | -1.4 |
| Display temp. | -1.4 | -1.4 | -1.4 | -1.4 | -1.4 | -1.4 | -1.4 | -1.4 |
| Air on Probe | -1.4 | -1.4 | -1.4 | -1.4 | -1.4 | -1.4 | -1.4 | -1.4 |
| Air off Probe | -1.4 | -1.4 | -1.4 | -1.4 | -1.4 | -1.4 | -1.4 | -1.4 |
| Evaporator Probe | -1.4 | -1.4 | -1.4 | -1.4 | -1.4 | -1.4 | -1.4 | -1.4 |
| Suc. Line Probe | -1.7 | -1.7 | -1.7 | -1.7 | -1.7 | -1.7 | -1.7 | -1.7 |
| Superheat | -0.3 | -0.3 | -0.3 | -0.3 | -0.3 | -0.3 | -0.3 | -0.3 |
| Logging Probe | N/A | N/A | N/A | N/A | N/A | N/A | N/A | N/A |
| Defrost Probe | N/A | N/A | N/A | N/A | N/A | N/A | N/A | N/A |
| Alarm temp. | -1.4 | -1.4 | -1.4 | -1.4 | -1.4 | -1.4 | -1.4 | -1.4 |
| Valve Opening | 10.0 | 10.0 | 10.0 | 10.0 | 50.0 | 50.0 | 50.0 | 50.0 |
| Liq. Line Valve | Open | Open | Open | Open | Open | Open | Open | Open |
| Suc.Line/Trims | Off | Off | Off | Off | Off | Off | Off | Off |

This is a view only screen

Mercury Controller Passcode

The configure menu allows access to all the controller’s settable parameters and requires a password to access.

Due to increased cyber security protection, implemented from April 2025 onwards, the Mercury range of controllers have a firmware update which removes the previous shipping default legacy password and replaces it with a unique passcode from the factory. This unique passcode can be changed by the engineer, if required, using a PC connection and the controller display.

Any version of Mercury controller will log onto a Data Manager front end as before, the April 2025 update only affects the Data Manager’s ability to change parameters on the Mercury controller. At the controller itself the normal method of accessing the “Para” menu using it’s display remains unchanged.

Action Overview

There are three possible actions to take when networking a Mercury, these are fully documented later in this application note, below is a summary table.

| Combinations | Action |
|--|---|
| New Mercury (post-April 2025) and new Data Manager (V4.2.3 or newer) | No action needed. Logon and network as before. |
| Older Mercury (pre-April 2025) and any Data Manager software version | No action needed. Logon and network as before. |
| New Mercury (post-April 2025) and older Data Manager (V4.2.2 or earlier) | Navigate to “PASS” via Mercury display and set to “OLD”. Logon and network as before. |



Using a new Mercury controller with a recent Data Manager

If connecting a new Mercury Controller (Manufactured on April 2025 or later) with a Data Manager with firmware version V4.2.3 or newer (Manufactured on September 2023 or later), then there will be no compatibility issues.

A quick way to determine if a Mercury controller is legacy or not is the "PASS" menu being present,

see: [Setting the legacy passcode on a new Mercury controller](#) later on in this document. If the "PASS" menu is **not** present then the controller is classed as a legacy controller (pre April 2025).

If connecting a PC directly to the Mercury controller the previous default legacy password will not work and a new passcode will need to be set up. The Mercury controller requires a built-in display or remote display (PR0725 for example) to enable this.

Using a legacy Mercury controller with a Data Manager

If connecting a legacy Mercury Controller (Manufactured **before** April 2025) with any Data Manager then there will be no compatibility issues.

If connecting a PC directly to the Mercury controller the legacy default password will work as before.

Using a new Mercury controller with a legacy Data Manager

If connecting a new Mercury Controller (Manufactured on April 2025 or later) with a Data Manager with firmware version V4.2.2 or earlier, then the Mercury controller will require the unique factory shipping passcode to be changed to enable the legacy Data Manager to make parameter changes in the controller.

If connecting a PC directly to the new Mercury controller the previous default legacy password will not work and a new passcode will need to be configured. The Mercury controller requires a built-in display or remote display (PR0725 for example) to enable this.

Setting the legacy passcode on a new Mercury controller

If using a new Mercury controller with a legacy Data Manager (V4.2.2 or earlier) a PC connection is not required and a legacy default passcode can be set using the controller's display.

To enter the setup menu on the Mercury Controller press and hold the Enter and Down keys for 3 seconds, the display will show "Ent", release both keys and press the Enter key and the display will show "IO", this is the Input/Output menu.

Press the Up or Down keys to scroll through the set up menus until the "PASS" menu is shown, press the Enter key to select. The display will show "Hi".

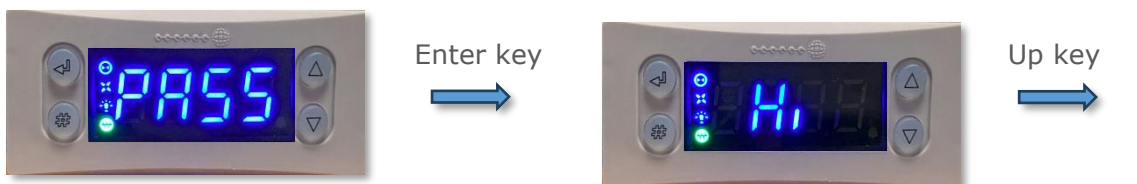

Pressing the Up key again will show "Lo" on the display, pressing the Up key again will show "Old".



Pressing the Enter key on "Old" will show "dFLt", this allows the legacy default passcode to set in the controller, pressing the Enter key again will set the legacy passcode and the display will return to "PASS".

The Legacy passcode is now set. Navigate to "Esc" and press the Enter key to save the setting otherwise the display will timeout after 60 seconds after no user interactions.

The Data Manager will now be able to set parameters in the Mercury controller.



Setting a PC or Laptop passcode.

A PC can be connected by surfing to an IP enabled controller's IP address using a web browser, if the controller is not IP enabled then RDM communicator software can be used to connect directly to the controller's RS232 port.

An external communication module such as an IP Futura (PR0016) or Intuitive Switch can be used to enable IP connectivity on any RS232 Mercury controller.

The controller's home page will be shown, similar to the one below.



Select the "Reset Password" option.

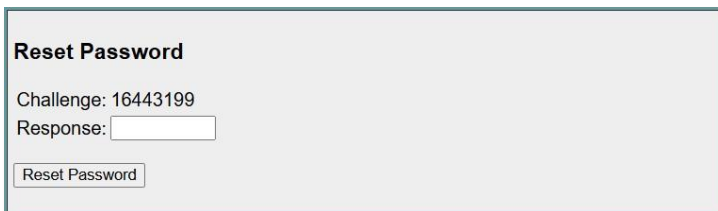

An 8 digit passcode is required to be entered in the Response field, this is comprised of the "Hi" an "Lo" values which can be obtained from the controller's display as follows.

Enter the setup menu on the Mercury Controller by pressing and holding the Enter and Down keys for 3 seconds, the display will show "Ent", release both keys and press the Enter key and the display will show "IO", this is the Input/Output menu.

Press the Up or Down keys to scroll through the set up menus until the "PASS" menu is shown, press the Enter key to select. The display will show "Hi".

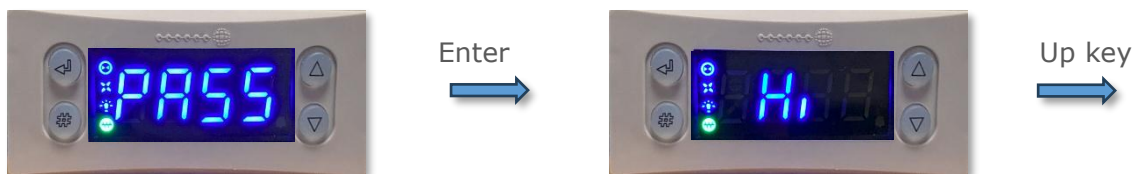

Press the Enter key again and the "Hi" code will be shown, 9901 for example, make a note of this code.



Press the Enter key again to return to the "Hi" menu, press the Up key to select the "Lo" menu.



Press the Enter key again and the "Lo" code will be shown, 5807 for example, make a note of this code.

The "Hi" code followed by the "Lo" code, 99015807 for example, can now be entered into the "Response" field in the PC interface.

Reset Password

Challenge: 16443199

Response:

The controller password is now reset and all the controller's service menu options are now accessible.

Setting a user defined Passcode

In most cases setting the legacy passcode is all that is required, however there is an option to set a unique user defined passcode in the controller.

Setting a user definable passcode is not essential but it allows the user to have their own unique passcode and does not require access to the controller's display (if fitted) to access the "Hi" and "Lo" values.

In the main "Configure" menu select "Set Password".

Configure

A new passcode can now be set, this should be a number between 4 and 8 digits in length.

Set Password

DO NOT change the password if you are unsure of the effect it may have.

Note: RDM frontends running earlier versions of software may require the old default password.

Enter Password:

Re-enter Password:



Using a Caesium Programming Adaptor (PR0726) or Communicator software.

If using any of the above programming devices, the Mercury password has to be set to the legacy passcode, see: [Setting the Legacy Passcode](#)

Configure

Click on the **Configure** button to access the setup menu.

Note: login credentials required to access Configure menu are as follows;

Username: 'service'
Password: As set in the above section

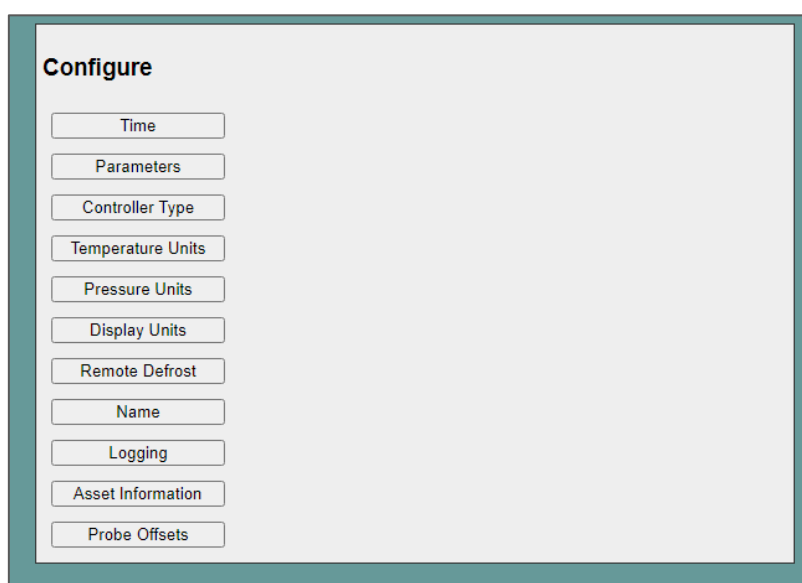

This screen allows the user to configure the controller and set-up the following: - **Time, Parameters, Controller Type, Pressure Units, Display Units, Remote Defrost, Name, Logging, Asset Information and Probe Offsets**

Time Screen

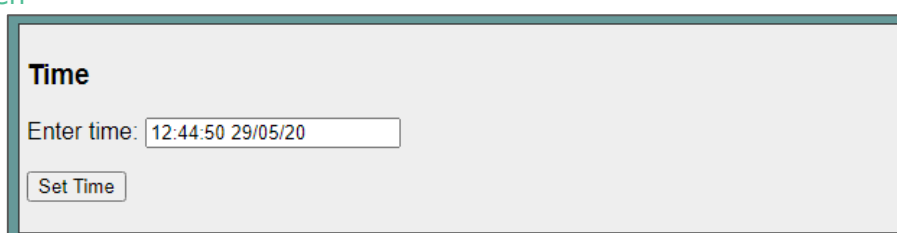

Enter the time and date in the format displayed and press "Set Time" to update the controller. A screen showing the set time will be displayed, and then revert to the initial (Home) screen.



Parameter Screen

Set Parameters

Use Set Parameters button to save changes before changing section

Control Alarms Defrost Lights

| Parameter Name | Low | High | Default | Value | Units |
|-------------------|-------|-------|---------|--|-------|
| Cut-in temp | -42.0 | 30.0 | -20.0 | <input type="text" value="30.0"/> | °C |
| Cut-in diff. | 0.0 | 10.0 | 2.5 | <input type="text" value="2.5"/> | °C |
| Control weight | 0 | 100 | 40 | <input type="text" value="40"/> | % |
| Display weight | 0 | 101 | 40 | <input type="text" value="40"/> | % |
| Alarm weight | 0 | 100 | 0 | <input type="text" value="0"/> | % |
| Lag Comp Delay | 00:00 | 15:00 | 00:40 | <input type="text" value="00:40"/> | mm:ss |
| Anti SC Time | 00:00 | 15:00 | 07:00 | <input type="text" value="07:00"/> | mm:ss |
| Lag Cut Out Diff | 0.0 | 10.0 | 2.5 | <input type="text" value="2.5"/> | °C |
| Key Switch | | | | <input type="button" value="KeyOff"/> | |
| Ctrl Probe Type | | | | <input type="button" value="Air Probe"/> | |
| Resistor Case Off | | | | <input type="button" value="Off"/> | |
| Fans Temp Mode | | | | <input type="button" value="Off"/> | |
| Fans Off Temp | -42.0 | 30.0 | -10.0 | <input type="text" value="-10.0"/> | °C |
| Probe 5 Select | | | | <input type="button" value="Defrost"/> | |
| Relay 3 Mode | | | | <input type="button" value="Lights"/> | |
| Probe 3 Resistor | | | | <input type="button" value="Plnt3 NO"/> | |
| Service Time | 0 | 128 | 60 | <input type="text" value="60"/> | K Hrs |
| Switch Resistors | | | | <input type="button" value="On"/> | |
| Lights CaseOff | | | | <input type="button" value="Unused"/> | |
| Load Shedding | | | | <input type="button" value="Off"/> | |
| Digital 1 Mode | | | | <input type="button" value="Plnt1 NO"/> | |
| Digital 2 Mode | | | | <input type="button" value="Plnt2 NO"/> | |
| Cut-in Offset | -30.0 | 30.0 | 5.0 | <input type="text" value="5.0"/> | °C |
| Probe 5 Resistor | | | | <input type="button" value="Plnt4 NO"/> | |

This screen allows the parameters to be changed. Once the values are changed, the “Set Parameter” button must be clicked to set the parameters into the controller.

A screen will show the number of parameters and the number changed, then revert back to the Home screen.

Controller Type

Controller Type

This screen allows the controller type to be changed. For this controller, there is 6 for the Mechanical type and 4 for the EEV type.



Temperature Units

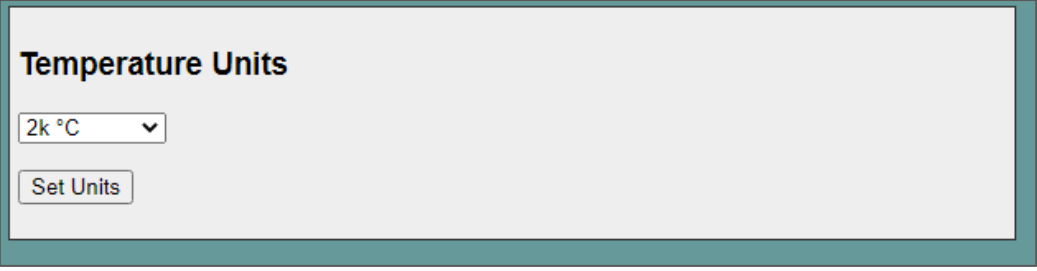

Temperature Units

2k °C

Set Units

This screen allows the user to set the probe type for the controller and if it's in degrees Centigrade or Fahrenheit.

Pressure Units

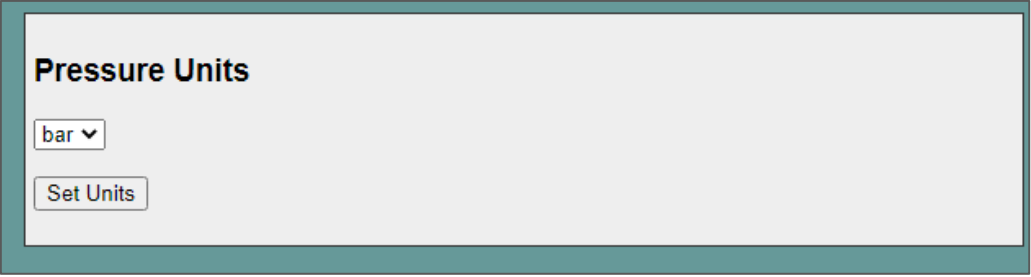

Pressure Units

bar

Set Units

This screen allows the user to set the pressure units displayed to Bar or PSI.

Display Units



Display Units

Decimal

Set Display Units

This screen allows the user to set if the display on the controller will display only whole numbers (Whole) or whole numbers and tenths (Decimal).

Remote Defrost

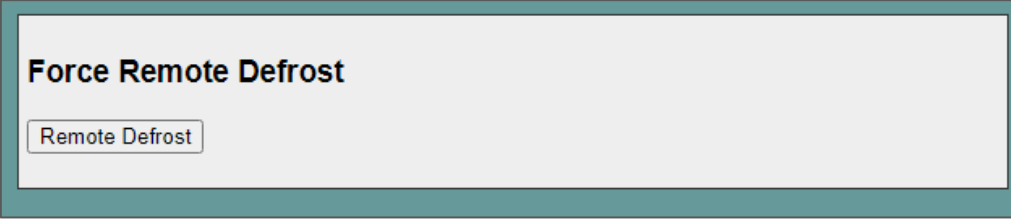

Force Remote Defrost

Remote Defrost

This screen allows the user to send a remote defrost to the controller (note: defrost mode must be set to local)



Name

Name

Enter Name:

This screen allows the user to give the controller a name. Type in a name of your choice (upper or lower case alpha-numeric) up to 32 characters. Click "Set Name" to load into the controller. A screen will show the name has been set and then revert back to the Home screen. (The Home screen will also now show the controller name.)

Logging

Logging

| Set 1 | | Set 2 | |
|------------------|-------------------------------------|------------------|--------------------------|
| Log Interval | 5s ▾ | Log Interval | None ▾ |
| Control temp. | <input checked="" type="checkbox"/> | Control temp. | <input type="checkbox"/> |
| Display temp. | <input checked="" type="checkbox"/> | Display temp. | <input type="checkbox"/> |
| Air on Probe | <input checked="" type="checkbox"/> | Air on Probe | <input type="checkbox"/> |
| Air off Probe | <input checked="" type="checkbox"/> | Air off Probe | <input type="checkbox"/> |
| Evaporator Probe | <input checked="" type="checkbox"/> | Evaporator Probe | <input type="checkbox"/> |
| Suc. Line Probe | <input checked="" type="checkbox"/> | Suc. Line Probe | <input type="checkbox"/> |
| Superheat | <input checked="" type="checkbox"/> | Superheat | <input type="checkbox"/> |
| Defrost Probe | <input checked="" type="checkbox"/> | Defrost Probe | <input type="checkbox"/> |
| Logging Probe | <input checked="" type="checkbox"/> | Logging Probe | <input type="checkbox"/> |
| Alarm temp. | <input checked="" type="checkbox"/> | Alarm temp. | <input type="checkbox"/> |
| Compressor A | <input checked="" type="checkbox"/> | Compressor A | <input type="checkbox"/> |
| Compressor B | <input checked="" type="checkbox"/> | Compressor B | <input type="checkbox"/> |
| Defrost Control | <input checked="" type="checkbox"/> | Defrost Control | <input type="checkbox"/> |

This screen allows the user to set the logging features. There are two sets so that values can have different log intervals.

Set the interval required on set1 and set 2, tick the required values to be logged, then click "Set Values" to load into the controller.

A screen will display "Log configuration set" then revert back to the Home page.



Asset Information

Asset Information

| Controller | | Equipment Manufacturer | |
|-------------------|--------------------|------------------------|--|
| Model | PR0740R MR 232 CAS | Manufacturer | |
| Serial No | RDM101110169 | Model | |
| Date | 18/10/19 | Serial No | |
| | | Date | |
| Installed Fixture | | Refurbished Fixture | |
| Asset | | Refurb By | |
| Installer | | Re-Asset | |
| Date | | Installer | |
| | | Date | |

This screen allows the user to set asset information into the controller.

Caution: This is a once only operation.

Click "Set Information" and follow the on screen instructions to set up your asset information.

Probe Offsets

Probe Offsets

| Probe | Low | High | Value | Units |
|-------|-----|------|----------------------------------|-------|
| 1 | -10 | 10 | <input type="text" value="0.0"/> | °C |
| 2 | -10 | 10 | <input type="text" value="0.0"/> | °C |
| 3 | -10 | 10 | <input type="text" value="0.0"/> | °C |
| 4 | -10 | 10 | <input type="text" value="0.0"/> | °C |
| 5 | -10 | 10 | <input type="text" value="0.0"/> | °C |
| 6 | -10 | 10 | <input type="text" value="0.0"/> | °C |

This screen allows the user to set a probe offset between -10 to +10 degrees to any of the six probes connected to the controller.

Set Password

Set Password

DO NOT change the password if you are unsure of the effect it may have.
Note: RDM frontends running earlier versions of software may require the old default password.

Enter Password:

Re-enter Password:

This screen allows the user to change the password from the default legacy password. Please be aware that this could have an adverse effect on communications between an RDM frontend running software earlier than version V4.2.3



Disclaimer

The specifications of the product detailed in this document may change without notice. RDM Ltd shall not be liable for errors or omissions, for incidental or consequential damages, directly or indirectly, in connection with the furnishing, performance or misuse of this product or document.



Revision History

| Soft M | Soft E | Doc Revision | Date | Changes |
|--------|--------|--------------|------------|--|
| 1.0 | 1.0 | | 01/03/2015 | Introduction of New Mercury hardware |
| 1.0 | 1.0 | A | 03/11/2015 | Connections drawing updated. |
| 1.0 | 1.0 | B | 07/01/2016 | Screw terminal maximum size added, note added to EEV/EET control description, SSR connection detail added, load shedding mode descriptions added |
| 1.0 | 1.0 | C | 18/01/2016 | P-83 Description updated to show correct order. |
| 1.0 | 1.0 | D | 16/02/2016 | Relay switching life cycle added to specifications. |
| 1.0 | 1.0 | E | 26/02/2016 | Mains and relay screw terminal sizes increased to 1.5mm ² |
| 1.0 | 1.0 | F | 10/03/2016 | Remote Lights Only command added. R449A and R513A gas added. |
| 3.1 | 3.1 | | 11/07/2016 | Matching Document and software versions. Superheat Options description updated |
| 3.1 | 3.1 | A | 18/11/2016 | Remote evap. Control description updated, PR0018-PHI cannot be used when broadcasting pressure directly from a pack controller to the Mercury, need to use a non-PHI hub or individual module (PR0016). |
| 3.1 | 3.1 | B | 14/02/2017 | Added ECA approval. |
| 3.1 | 3.1 | C | 20/02/2017 | New documentation format. |
| 3.1 | 3.1 | D | 13/04/2017 | Allow Load Shedding when in OT and UT state. |
| 3.1 | 3.1 | E | 17/05/2017 | Operating temperature amended. |
| 3.2 | 3.2 | | 01/06/2017 | Amendment to MOP functionality added. Refrigerant gas table updated. Ref weight parameter added. |
| 3.3 | 3.3 | | 31/07/2017 | Plant faults 2 & 3 added, added new parameter Cut in Offset. Support added to allow defrost skip functionality with remote defrost. |
| 3.3 | 3.3 | A | 28/11/2017 | Alarm weight (P-5 & P-10) and Probe 2 Alarm (P-58 & P-30) parameters added. Input 10 (Alarm Temp) added, NTC10K probes updated. Added new menu option for pressure unit selection. |
| 3.4 | 3.4 | | 20/04/2018 | Parameter to turn off the local defrost button (#) on the display on EEV version |
| 3.4 | 3.4 | A | 14/06/2018 | Alarm Weight and Probe 2 Alarm Parameters added to user guide |
| 3.5 | 3.5 | | 08/08/2018 | Remote command to change Superheat Offset added. |
| 3.5 | 3.5 | A | 20/08/2018 | Range of P-34 (Glide) updated. |
| 3.5 | 3.5 | B | 23/10/2018 | P-102 Description amended. |
| 3.5 | 3.5 | C | 10/11/2018 | Note added on EEV control types, description of P-56 minimum valve opening updated. |
| 3.6 | 3.6 | D | 26/11/2018 | Defrost Cycles picture amended. |
| 3.7 | 3.7 | E | 07/12/2018 | RDM USA address updated |
| 3.7 | 3.7 | F | 18/04/2019 | Note added regarding relay N/O and N/C connections. |
| 4.0 | 4.0 | | 30/05/2019 | Update to include Pres and Test menu descriptions |
| 4.1 | 4.1 | | 03/09/2019 | Remote Fans Only command added. Function to show log probe on display added. Additional over temperature setpoint for logging probes during defrost added. R455A and R454C gas added. Ability to setup custom gases added. Custom voltage range for local transducers added. Intuitive Mercury hardware added. |
| 4.1B | 4.1B | B | 04/10/2019 | Update to Intuitive Wiring Diagram |
| 4.1C | 4.1C | C | 27/11/2019 | Update to DI and MOP descriptions |
| 4.1D | 4.1D | D | 10/01/2020 | Update to Specification |
| 4.1 | 4.1 | E | 17/01/2020 | 'dtyP' menu option added, this allows you to use a Mercury or Coldroom display. |
| 4.2 | 4.2 | | 30/03/2020 | Fan Control option now available on all types on M & E. Option added to defrost type parameter on the M controller to allow both compressors to run during a hot gas defrost. |
| 4.2 | 4.2 | A | 01/06/2020 | Webpage appearance added. |
| 4.6 | 4.9 | A | 23/06/2020 | Door switch NO or NC added. |
| 4.8 | 5.0 | A | 07/12/2020 | Bluetooth network support added. |
| 4.8 | 5.0 | B | 23/09/2021 | Note added regarding setting ref weighting to 100% for evaporator control. |
| 5.0 | 5.1 | | 03/02/2022 | Mercury PR0744 added with relays for use with hydrocarbon refrigerants. SSR relay specification added. Compressors rotate |



| | | | | |
|-----|-----|---|------------|--|
| | | | | duty after defrost. MOP delay units corrected from hh:mm to mm:ss. |
| 5.0 | 5.1 | A | 16/02/2022 | Intuitive Switch part numbers added, safety compliance updated to EN60730, note added regarding use of 0-10v transducer being externally powered, coldroom display part number added |
| 5.0 | 5.1 | B | 17/02/2022 | Relays to standards IEC60079-0 and IEC60079-15 specified for PR0744 |
| 5.0 | 5.2 | C | 25/10/2022 | 4-20mA transducer accuracy added +/- 0.5mA |
| 5.0 | 5.2 | D | 30/01/2023 | Relay 5 supply details updated |
| 5.0 | 5.3 | A | 01/11/2023 | Improvements made to defrost cycle on EEV software |
| 5.0 | 5.3 | B | 19/12/2023 | Details on SSR connection on Intuitive variant added, SSR maximum current rating revised. PR0744 variant removed to separate user guide. |
| 5.1 | 5.4 | C | 03/10/2024 | Support for front end overrides added. Controller password can be changed from default. Note added regarding no diff around defrost cln parameter. |
| 5.1 | 5.5 | A | 14/04/2025 | Password security updated in E version. New refrigerant table added. |
| 5.3 | 5.5 | | 17/07/2025 | Addition of doorswitch input on non coldroom types on M type only. Addition of slug display parameter. Addition of Comp Startup Delay Parameter (P-08). Note added regarding non-functioning of Door stops Valve P Parameter (P-81). Password security updated in M version. Update to alarm handling after defrost on M variant. |



Group Offices

RDM Group Head Office

80 Johnstone Avenue
Hillington Industrial Estate
Glasgow
G52 4NZ
United Kingdom

+44 (0)141 810 2828
support@resourcedm.com

RDM Inc.

9441 Science Center Drive
New Hope
Minneapolis, MN
55428
United States

+1 612 354 3923
usasupport@resourcedm.com

RDM Asia

Sky Park at One City
Jalan USJ 25/1
47650 Subang Jaya
Selangor
Malaysia

+60 3 5022 3188
asiatech@resourcedm.com



Visit www.resourcedm.com/support for more information on RDM solutions, additional product documentation and software downloads.

While every effort is made to ensure the information given within this document is accurate, Resource Data Management Ltd shall not be liable for errors or omissions, for incidental or consequential damages, directly or indirectly, in connection with the furnishing, performance or misuse of this product or document. All specifications are subject to change without notice.

See www.resourcedm.com for terms and conditions of sales.

Copyright © Resource Data Management