



PR0733

PR0732-NI
PR0732-POE
PR0734

Wireless Battery Temperature Probe Installation & User Guide

Resource Data Management

UK OFFICE

Resource Data Management Ltd
80 Johnstone Avenue,
Hillington Industrial Estate,
Glasgow, Scotland, G52 4NZ, UK
☎ +44(0)141 810 2828
✉ sales@resourcedm.com

US OFFICE

Resource Data Management Inc
100 North Sixth Street,
Suite 630B,
Minneapolis, MN 55403, USA
☎ Tel +1 612 354 3923
✉ usasales@resourcedm.com



Table of Contents:

WIRELESS BATTERY PROBE..... 3

Enclosure..... 3

Configuration..... 4

 Network..... 4

Network ID..... 4

Current Status..... 5

Logging on a Wireless Probe to the Data Manager..... 5

Wireless Probe Example System..... 6

Network Repeater..... 6

Wireless Mesh Base Units..... 7

 PR0732 – Ethernet IP Router..... 7

 Option 1 – Direct Power Supply – PR0732-NI..... 8

 Option 2 – Power Over Ethernet (POE) – PR0732-POE..... 8

 PR0734 – USB Interface..... 9

 Multiple Base Units..... 9

Parameter Table..... 10

Network Alarms..... 10

Related Part Numbers..... 10

Technical Specification..... 11

 General Radio Data..... 11

 Maximum Number Of Devices Per Network..... 11

 Radio Equipment Present..... 11

Cleaning..... 11

Mounting and Installation Instructions..... 12

Disclaimer..... 12

Revision History..... 12

Before installing or using this product, read the contents of this guide thoroughly to familiarise yourself with all the operating parameters and features. Please refer to the information detailed in the [Technical Specification](#) section.

Wireless Battery Probe

From Resource Data Management

The RDM Wireless Probe is a battery powered device for use in temperature monitoring applications. The unit is completely self-contained with no user serviceable parts. The battery supplied with the Wireless Probe is designed to provide a minimum of 5 years operation and the unit can be used in temperature monitoring applications from -5°C (23°F) up to + 50°C (122°F). The RDM part number is PR0733.

The Wireless Probe has an over and under temperature alarm set point with an associated alarm delay. The Wireless Probe uses the latest ZigBee wireless technology which allows it to integrate to an existing RDM Wireless Mesh solution, although the Wireless Probe itself is not a Mesh device. To optimise battery life the device “wakes up” every 10 minutes to sample the temperature before sending the data to an RDM Data Manager. The Wireless Probe is logged on to a Data Manager front end system, via a Wireless Mesh Base unit. The Wireless Mesh Base unit is available as either an Ethernet device (PR0732) or USB device (PR0734), this allows for temperature monitoring without the need for a full site wired network infrastructure. This provides greater flexibility for monitoring solutions in applications where the installation of a wired network isn’t feasible or cost effective.

The Wireless Probe has a unique feature which allows it to store up to 72 hours of temperature data. This data is stored should the unit lose communication with the Data Manager on which it is networked. When communications are restored the logged data will be uploaded from the Wireless Probe to the Data Manager, thus the user can review the logged temperature data for the period of time the Wireless Probe was offline.

NB - Data Manager Software V2.0.4 or above is required (V1.54.3 using older wireless base mesh unit). If the Data Manager is powered off it will not recover temperature logs for the period over which the Data Manager has been switched off.

This product is for medium and high temperature applications only and is not suitable for frozen food applications, using the product in environments where the temperature is less than -5°C (23°F) will invalidate the 5 year warranty.

Enclosure

Oblique View



Bottom view

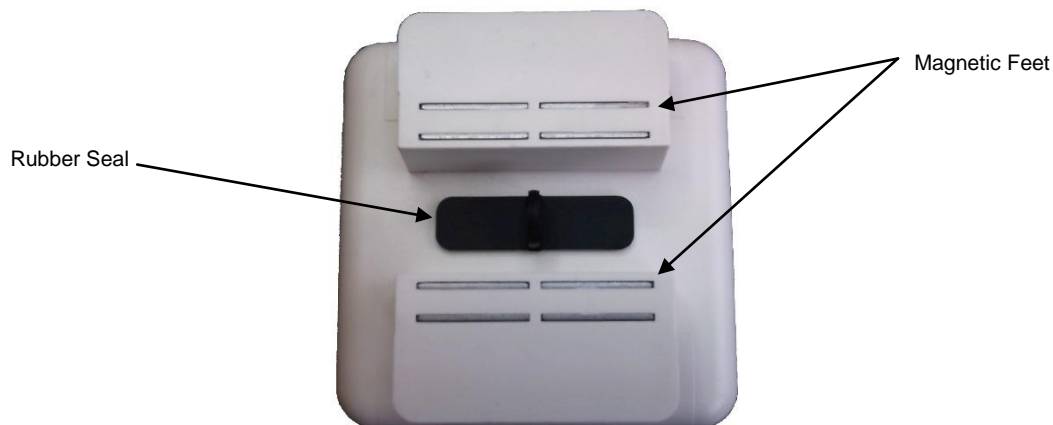

The unit has magnetic feet which allow for quick and easy installation. The rubber seal has to be fitted to achieve the maximum IP rating. Failure to fit the rubber seal could result in premature failure of the device and may result in the user invalidating the 5 year warranty supplied with the product.

Configuration

Removing the rubber seal reveals a series of bit switches, a serial connection, push button and bi colour LED.

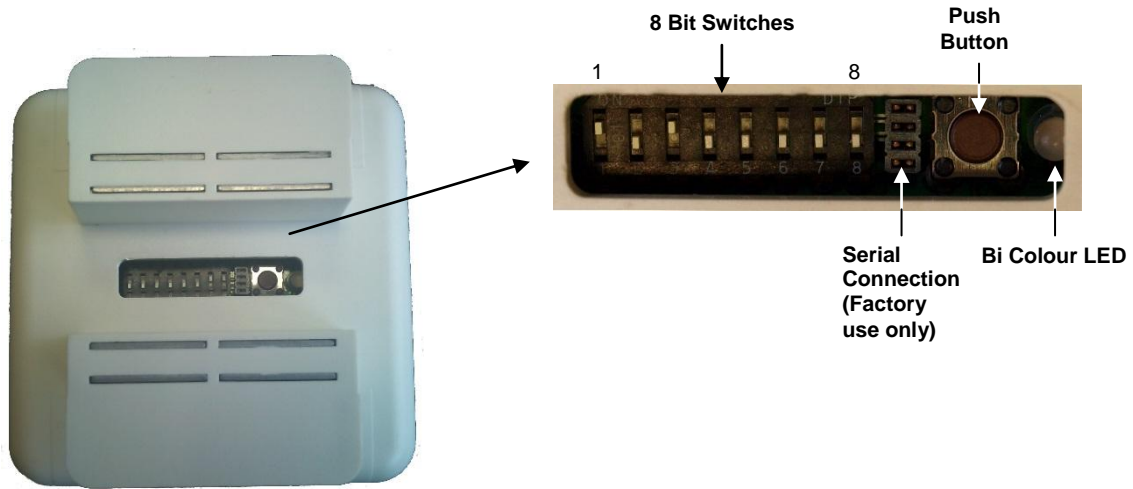

Network

The Wireless Probe has 8 bit switches numbered 1 through to 8. These are used when networking the device. Bit switches 1 through to 6 are used to assign a unique network address to an individual Wireless Probe. Bit switches 7 and 8 are used to determine the “Net ID” of the probe. Please refer to the table below.

Bit Switches							
1	2	3	4	5	6	7	8
Probe ID						Net ID	
000000 = 0	000010 = 16	000001 = 32	000011 = 48	<div style="border: 1px solid black; padding: 5px;"> 00 = 0 10 = 1 01 = 2 11 = 3 </div>			
100000 = 1	100010 = 17	100001 = 33	100011 = 49				
010000 = 2	010010 = 18	010001 = 34	010011 = 50				
110000 = 3	110010 = 19	110001 = 35	110011 = 51				
001000 = 4	001010 = 20	001001 = 36	001011 = 52				
101000 = 5	101010 = 21	101001 = 37	101011 = 53				
011000 = 6	011010 = 22	011001 = 38	011011 = 54				
111000 = 7	111010 = 23	111001 = 39	111011 = 55				
000100 = 8	000110 = 24	000101 = 40	000111 = 56				
100100 = 9	100110 = 25	100101 = 41	100111 = 57				
010100 = 10	010110 = 26	010101 = 42	010111 = 58				
110100 = 11	110110 = 27	110101 = 43	110111 = 59				
001100 = 12	001110 = 28	001101 = 44	001111 = 60				
101100 = 13	101110 = 29	101101 = 45	101111 = 61				
011100 = 14	011110 = 30	011101 = 46	011111 = 62				
111100 = 15	111110 = 31	111101 = 47	111111 = 63				

A network address of 0 through to 63 can be assigned. This allows up to 64 Wireless Probes to logon to a single wireless mesh network. A Data Manager provides support for up to 4 wireless mesh networks, potentially allowing 256 Wireless Probes to logon to a single Data Manager. If a Probe ID of 000010 is assigned then the device will log on to the Data Manager and appear in the device list as WPR016. If a Probe ID of 11111111 is assigned then the device will log on to the Data Manager and appear in the device list as WPR063 etc.

Network ID

Communication between the Wireless Probe and the Data Manager is dependent on the same Network ID being selected in both units. The Data Manager wireless mesh page must be configured before logging on any Wireless Probe. The Data Manager can be set to either Net ID 0, 1, 2 or 3. This allows a number of wireless mesh networks to operate in the same area without interfering with each other.

Use bit switch 7 & 8 to assign the required Net ID to allow the Wireless Probe to logon to the desired Data Manager.

Note: if the Network ID in the Data Manager is altered then each Wireless Probe will have to have it's Net ID changed accordingly. If the RF Channel in the Data Manager changes, the Wireless Probe will update accordingly and automatically after a short delay.

Current Status

A single press of the push button at any time will provide an indication to the Wireless Probes state.

- 3 red flashes Not configured
- 3 green flashes Configured

Note: three green flashes of the LED denote the unit has been configured and has established communication with a Data Manager at some point, but it doesn't prove if the unit is currently in communication with the Data Manager.

Logging on a Wireless Probe to the Data Manager

The following steps should be followed when logging on a Wireless Probe to the Data Manager.

See also [Mounting and Installation Instructions](#)

- 1) Ensure the Data Manager has software version V2.0.4 or greater (V1.54.3 for older base unit).
- 2) Ensure the Wireless Mesh interface (PR0735) is enabled in the Data Manager "System Configuration" Note a single PR0735 will allow up to 32 devices to log on. Multiple PR0735's will be needed if more than 32 Wireless Probes are required to be logged on.
- 3) Now connect either the Ethernet or USB Wireless Mesh Base unit to the Data Manager. If using the Ethernet device ensure it is powered on.
- 4) Configure the "Wireless Network Setup" page in the Data Manager. Add the desired Wireless Mesh Base unit and set the desired "Net ID" and the "RF Channel". Note: using the "Auto" option for the "RF Channel" allows the Wireless Mesh Base unit to scan the existing site and select an RF Channel not in use.
- 5) Set the Network ID on a given Wireless Probe, bit switches 7 & 8, to match that of the Data Manager and Wireless Mesh base unit you wish to log the Wireless Probe on to.
- 6) Now set bit switches 1 to 6 on the Wireless Probe to the desired address.
- 7) Now press and hold the push button. Once the LED has flashed red three times release the push button.
- 8) The LED will alternate red/green while attempting to log on. If successful, the LED will flash green. If unsuccessful, the LED will flash red.
- 9) If the unit fails to log on repeat step 7. If it fails a second time the Wireless Probe could be out of range. A network repeater may be required to resolve this issue.
- 10) After a short duration the Wireless Probe will appear in the Data Manager's device list. At this point check and edit the parameters as required.
- 11) Check the alarm delay in the Data Manager Site Setup page. Since the Wireless Probe attempts to communicate with the Data Manager every 10 minutes the Offline Alarm delay should be no less than 20 minutes.

If the wrong address has been entered into the Wireless Probe or you would like to turn off the unit then decommission the Wireless Probe. To do this press and hold the push button for 3 seconds. The LED will flash green 3 times, when 3rd green status flash has finished this denotes the module is decommissioned. A subsequent single press should show the status as not configured as the LED will flash red three times. If the wrong address had been previously entered then follow the above instructions to log the Wireless Probe on with the correct address. Note: when the unit is decommissioned it will still consume power.

Always attempt to logon the Wireless Probe from the location in which it will be fitted. Printed on the side of every Wireless Probe is a unique MAC address. When logged onto a Data Manager the MAC address for each probe is shown in the Device Info page. If a Wireless Probe is inadvertently removed from the Data Manager Device List by the user it will automatically log back on the next time the Wireless Probe reports its temperature data.

Wireless Probe Example System

Data Manager

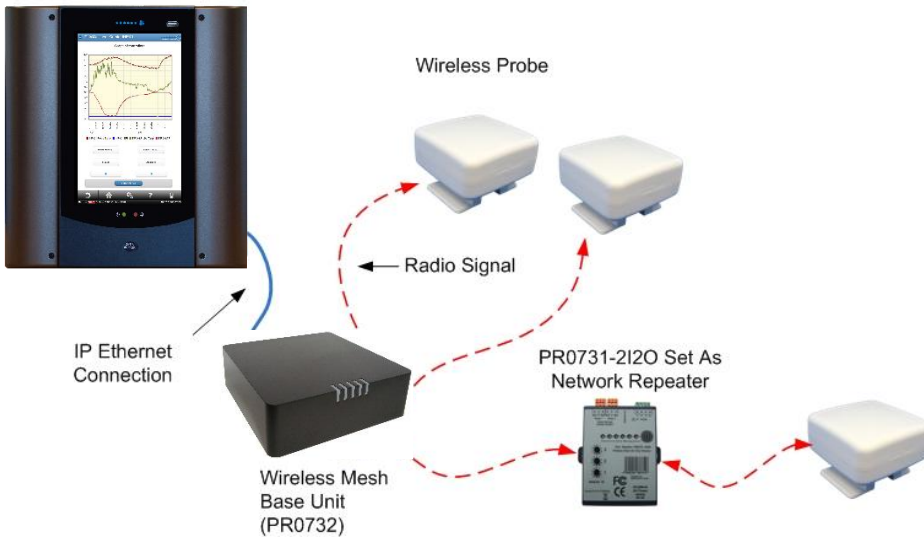

In the example shown a number of Wireless Probes are connected to a Data Manager via an Ethernet Wireless Mesh Base unit. The Wireless Mesh Base unit is connected to the Data Managers Ethernet 0 IP network via a CAT5 patch cable (see section on [Wireless Mesh Base Unit](#)).

The Wireless Probe transmits data to/from the Wireless Mesh Base unit as a radio signal. The Wireless Mesh Base unit in turn passes the data on to the Data Manager via its Ethernet network connection. This same process allows the Data Manager to send data to the Wireless Probes.

Network Repeater

Since the Wireless Probe wakes up every 10 minutes to report the current temperature before returning to a low power sleep mode, communication issues can occur if the Wireless Probe doesn't have direct communication to the Data Manager. If communication issues are encountered setting the rotary switches on a Wireless Mesh 4I module (PR0731-4I) or 2I2O module (PR0731-2I2O) module to '000' will enable the module to act as a repeater for the network traffic. The repeater module will not appear on the Data Manager as a device. These repeater modules can then be placed around the installation to provide a wireless network infrastructure. In the example above a PR0731-2I2O has been used as a network repeater.

Note - a maximum of 16 Wireless Probes can connect to a single Wireless Mesh Base Unit or Network Repeater Module. For example if a site has 30 Wireless Probes and an Ethernet Wireless Mesh Base unit has been utilised then a maximum of 16 Wireless Probes will log onto the wireless base unit only. The remaining probes would have to log on to a Network Repeater. However to ensure good coverage it is recommended to limit the number of probes to a maximum of 10 per Repeater Module.

For further details on the 2I2O and 4I modules please refer to the appropriate user document.

Wireless Mesh Base Units

The Wireless Mesh Base Unit comes in two hardware platforms. An Ethernet IP router (PR0732) or a USB interface (PR0734). Both units allow data to be exchanged between the Data Manager and the communication modules connected to the wireless mesh network. Both of the wireless mesh base units are configured through the Data Manager. **Please see the Data Manager User guide for further details.**

NB – The new Wireless mesh base unit (pictured below) will work with DM software V2.0.4 and above.

PR0732 – Ethernet IP Router

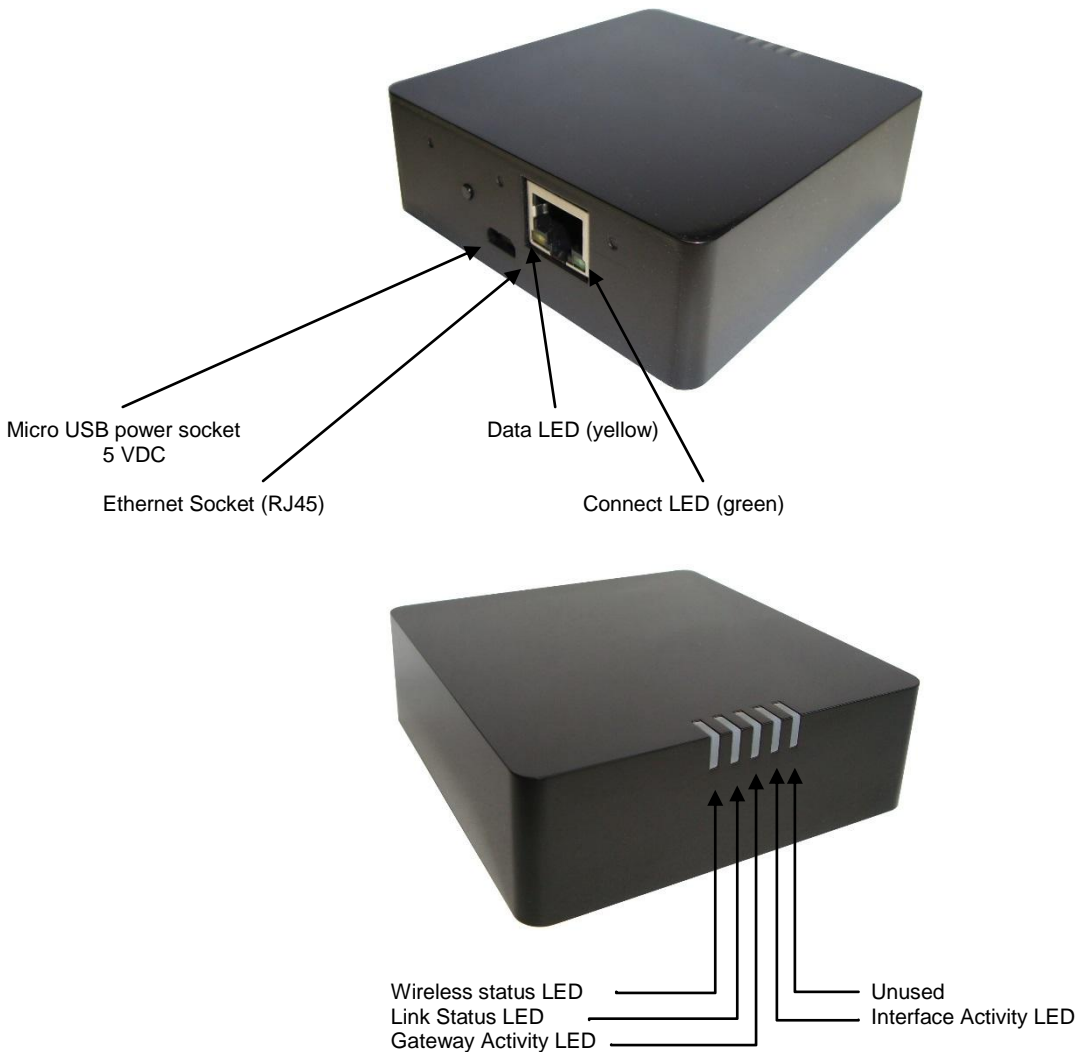

Wireless Mesh Unit Front LED status indicators

Wireless status LED	-	static orange when wireless is on
Link status LED	-	static green when device has IP address
Gateway status LED	-	blinks orange with general communication through device
Interface status LED	-	static green when DM has a connection

NB – refrain from pushing any buttons on the unit. If you require assistance please contact RDM support.

When connected, the unit will receive an IP address from the Data Manager's DHCP server (with DHCP function ticked). This enables the wireless device attached to the wireless mesh to log on to the Data Manager and appear in the device list. There are two LED's present on the rear of the Wireless base unit Ethernet connector, once the Ethernet connection is established the orange LED will come on and remain on and the yellow LED will flash to indicate data transfer.

Option 1 – Direct Power Supply – PR0732-NI

There are two methods to which the wireless IP router can be connected to the Data Manager. The first, simply uses its IP interface to directly connect to the Data Manager's Ethernet 0 IP network via a CAT5 cable where the Wireless Mesh base unit is powered from a direct power supply (Micro USB connector).

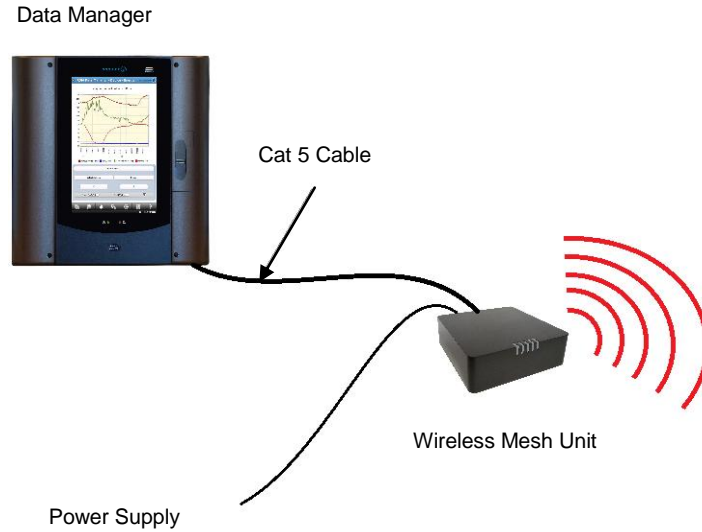

Option 2 – Power Over Ethernet (POE) – PR0732-POE

The second utilises the Power over Ethernet standard (POE). If the wireless mesh base unit is ordered with this function (PR0732-POE) then there will be an additional unit supplied, a POE injector. In this instance the Wireless Mesh base unit is powered directly via the CAT5 lead and would require no additional power supply. The POE injector is powered separately and is connected directly to the Ethernet 0 network of the Data Manager (LAN IN). The second IP (LAN OUT) port of the injector will be to communicate and power the Wireless Mesh base unit.

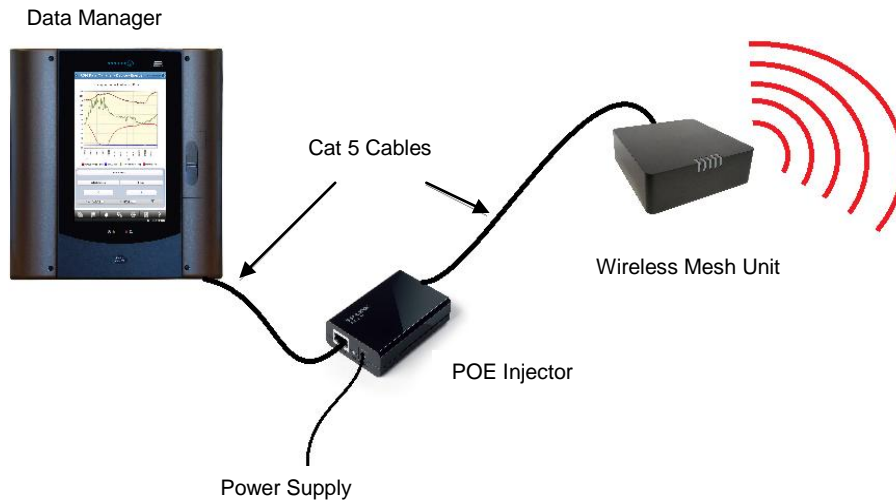

Please refer to the CAT5 standard with regards to maximum cable lengths. The POE injector will supply power up to 100m of cable.

PR0734 – USB Interface



The USB interface connects to any one of the five USB ports found on the Data Manager. When configured it allows a Wireless Probe to log on to the Data Manager and appear in the controller device list. There is a single status LED present on the USB interface which indicates when the USB interface is operating. The advantage the USB interface has is that no external power supply is required as it is USB powered and it can be conveniently fitted under one of the Data Manager's side covers.

NB - Data Manager software V1.54.3 or above is required for the USB interface to operate.

Both of the Wireless Mesh Base units are configured through the Data Manager. Please see the Data Manager user guide for further details.

Multiple Base Units

The Data Manager can support up to four wireless mesh base units (any combination of PR0732's and PR0734's). This is advantageous should the wireless network be split across multiple floors in a building. Shown below is a simplified network configuration with two wireless mesh base units.

NB – The base unit requires DM software V2.0.4 and above. The older base unit requires DM software V1.54.3 and above.

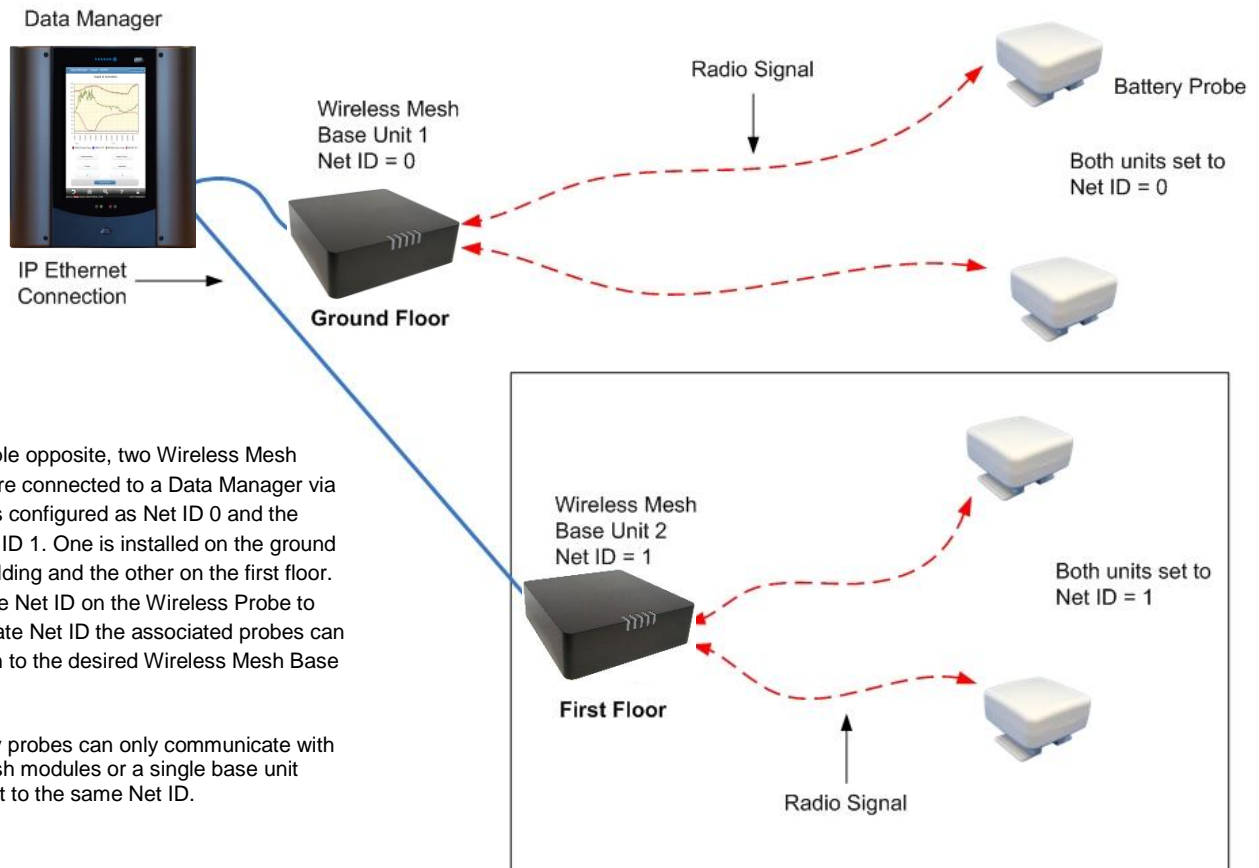

In the example opposite, two Wireless Mesh Base units are connected to a Data Manager via Eth 0. One is configured as Net ID 0 and the other as Net ID 1. One is installed on the ground floor of a building and the other on the first floor. By setting the Net ID on the Wireless Probe to the appropriate Net ID the associated probes can be logged on to the desired Wireless Mesh Base unit.

Note: battery probes can only communicate with wireless mesh modules or a single base unit which are set to the same Net ID.

Parameter Table

Once the Wireless Probe has been addressed and has logged onto the Data Manager the following parameters can be reviewed and changed if necessary.

Parameter	Range oC (oF)	Step	Units	Default oC (oF)	Comments
OT Alarm	-30 to +50 (-130 to +260)	0.1	Deg	50.0 (122)	Over temperature alarm setpoint
UT Alarm	-30 to +50 (-130 to +260)	0.1	Deg	-20.0 (-4.0)	Under temperature alarm setpoint
Alarm Delay	00:00 to 99:00	10:00	mm:ss	20:00	Alarm delay OT and UT alarms.

Network Alarms

The table below shows the text and associated type number that is sent to the system "front end". The type number is normally used to provide different alarm actions.

Alarm text	Type # (Index #)
Probe Over Temperature	4
Probe Under Temperature	5
Probe Fault	6

Related Part Numbers

Description	Part Number
Wireless Mesh Ethernet Base Unit (No POE injector)	PR0732-NI
Wireless Mesh Ethernet Base Unit (With POE injector)	PR0732-POE
Wireless Base Unit USB (Inc USB Extension Cable)	PR0734
Data Manager Wireless Software Enabler per 32 Devices	PR0735
2I2O Module °C (Including Power Supply)	PR0731-C-2I2O
2I2O Module °F (Including Power Supply)	PR0731-F-2I2O
4I Module °C (Including Power Supply)	PR0731-C-4I
4I Module °F (Including Power Supply)	PR0731-F-4I
Mercury 2 Wireless Mesh Communications Module	PR0730

Technical Specification

Note the product must be used as detailed by the manufacturer, failure to comply may result in incorrect operation of the product or premature failure.

Supply Voltage:	Battery Powered 3.6V*		
Operating temperature range:	-5°C (23°F) to +50°C (122°F)		
Operating Humidity:	80% Maximum Non-Condensing		
Storage temperature range:	-5°C (23°F) to +65°C (149°F)		
Environmental:	Indoor use at altitudes up to 2000m, Pollution Degree II,		
IP Rating	65		
Size:	75mm (L) x 75mm (W) x 52mm (D)		
Weight:	154 Grams		
Accuracy:	At temperatures	-5°C (23°F) to 40°C (104°F):	+/- 0.5 °C
	At temperatures	40°C (104°F) +:	+/- 0.6 °C
Resolution:	0.1°C		
Safety:	EN61010-1:2001		
EMC:	ETSI EN 301 489-17: V1.2.1:2002		
	ETSI EN 301 489-1: V1.1.1:2008		
Ventilation:	There is no requirement for forced cooling ventilation		
Disposal	Please observe local legislation with regards to electrical products.		
Origins	Product designed in the UK manufactured in Taiwan.		

* The battery is not accessible to the end user. Contact RDM regarding replacement battery procedures.

General Radio Data

Radio Frequency specification	16 Channels selectable in the Data Manager from 2400MHz to 2483.5MHz
Wireless Protocol	Zigbee
Output Power	+3dBm
Maximum Number Hops	30 Hops to the Wireless Mesh Base Unit.
Range	Typically 30M from one wireless mesh device to another. Range dependant on site conditions. Obstacles such as metal structures and the presence of other 3 rd party wireless devices operating in the same frequency range affect the maximum range achievable.

Maximum Number Of Devices Per Network

The RDM Wireless mesh solution is highly flexible and allows for the following configurations on a single Wireless Mesh Base Unit (PR0732 or PR0734): -

A total of 128 2I2O/4I modules	PR0731-2I2O & PR0731-4I
or	
A total of 32 Communication modules*	PR0730
or	
A combination of 2I2O/4I & Communication modules*	PR0731-2I2O, PR0731-4I & PR0730

* 32 is the recommended number of devices per Wireless Mesh base unit however depending on site conditions it may be possible to network up to 64 devices. Modules configured as repeater units do not form part of the above count. Wireless Battery Probes are excluded and are limited to 64 units per Wireless Mesh base unit.

Up to 4 Wireless Mesh base units can be connected to a single Data Manager. A software enabler is required per 32 devices (PR0735)

Radio Equipment Present

WARNING: To satisfy FCC RF exposure requirements for mobile transmitting devices, a separation distance of 20cm or more should be maintained between the antenna of this device and persons during operation. To ensure compliance, operations at closer distances than this are not recommended. Contains Transmitter Module FCC ID: T7VEM250

Cleaning

Clean the product by wiping with slightly dampened lint free cloth.

Mounting and Installation Instructions

The unit has magnetic feet which allow for quick and easy installation. A plastic mounting adapter is available which allows for the unit to be mounted on non-metallic surfaces.

Battery Probe Bracket White PR0032-WHI

Battery Probe Bracket Zirconium PR0033-ZIR

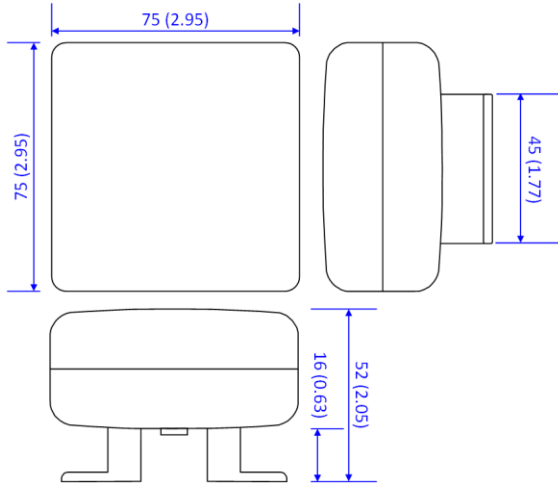

The installation instructions apply to both the Wireless Probe and the Wireless Mesh Base unit.

- When installing the Wireless Probe try to avoid physical obstacles which block direct line of sight with the Wireless Mesh Base unit such as brick walls, metal structures etc as this may reduce the effectiveness of the radio signal.
- The Wireless Mesh Base unit should be mounted centrally within the installation in relation to the majority of the Wireless Probes. Care must be taken to position the base unit away from physical obstacles so that the wireless base unit can be detected by most Wireless Probes.
- As with all radio equipment avoid mounting the module nearby other Electronic equipment as to minimise the possibility of interference.
- When mounting the module avoid metal surfaces, where possible, to maximise the radio signal range.
- Avoid mounting the Wireless Probe in between two metal surfaces.
- When mounting a Wireless Probe inside an enclosed metal object, transmission range is greatly reduced.

Disclaimer

The specifications of the product detailed in this document may change without notice. RDM Ltd shall not be liable for errors or omissions, for incidental or consequential damages, directly or indirectly, in connection with the furnishing, performance or misuse of this product or document.

Revision History

Revision	Date	Changes
1.0b	01/03/2011	1 st Issue
1.0d	26/06/2012	New look
1.0g	10/04/2014	New look base unit
1.0h	08/06/2016	Addition to specification
1.0i	25/08/2016	Minimum operating temperature changed to -5°C (23 °F)