

Resource
Data Management

Smart Coldroom Controller

Commissioning/User Guide
Revision 1.2f



PR0946

Contents

The SmaRt Coldroom Controller Range	3
Variants	3
Configuration	3
Compatible Network Interfaces	3
Front Display Features	4
Input and Output Allocation Tables	4
Typical Connection Diagram	5
Quick Start Menu Map	6
Setup through front buttons	7
Setup Function Menu	7
Recommended set-up method	7
Type. Set/view controller type	7
Unit. Set/view temperature unit	7
ParA. Set/view parameters (This can be achieved at the network front end)	8
Parameter Tables	8
Parameter Descriptions	9
Lighting Control	10
Relay and screen states during defrost	10
CnEt	10
IP-L	11
IP-r	11
Viewing	12
Input / Output Table	12
Messages	12
Network Alarms	12
Remote Commands	13
Network Interfaces	14
PR0944 Connections	14
PR0945 Connections	14
Using the SmaRt Caesium Programming Adapter (PR0948)	15
Specification	17
Installation	18
Fixing	18
Cleaning	18
Disclaimer	18
Display Remote Mounting	19
Display dimensions and fixing	19
Appendix 1: SmaRt Controller Modbus® register address table	20
Revision History	22



The SmaRt Coldroom Controller Range

From Resource Data Management

The SmaRt coldroom controller is a low cost self contained controller primarily intended for use in refrigerated coldrooms. It has two temperature probe inputs, a door switch input, a person trap alarm input, four fused relay outputs, built in temperature display with keypad and alarm sounder, and can be specified with or without a 40 Amp isolator switch.

The first temperature probe is an air on evaporator probe and the second is user selectable between air off evaporator probe or defrost termination probe.

The first relay is for cooling control, the second relay fan control and the third and fourth relays are user selectable as defrost control, lighting control or as an alarm relay. All relays have changeover contacts with normally open and normally closed connections, the relay common live connections are fed internally from the isolator switch to reduce the amount of onsite wiring required.

The controller has some features which are designed to help energy saving such as the "pulse fans" parameter and "defrost skip" parameter, see parameter section for further details.

There is also a network connection socket which allows the controller to communicate over IP with a suitably equipped Data Manager panel using the SmaRt network module and cable

The SmaRt controller range does not support electronic expansion valve control, for these applications please refer to the PR0150 Coldroom Controller range.

Variants

Description	Part Number
SmaRt coldroom controller, no isolator switch.	PR0946 N
SmaRt coldroom controller, with isolator switch.	PR0946 S

Configuration

The controller has three configuration type options built in which are selectable using the display buttons, this allows the controller to be quickly set up with minimal programming.

Type value	
1	Coldroom HT
2	Coldroom MT
3	Coldroom LT

The controllers are delivered pre-configured as type 1 HT.

Compatible Network Interfaces

SmaRt Controllers are capable of connecting to a Data Manager panel to allow features such as data logging, alarm reporting and remote access, to do this a SmaRt network module and SmaRt communications cable is required before connecting the Data Manager's IP network.

The network module will be automatically detected on power up.

Description	Part Number
SmaRt network module, DIN Rail Mount (Single SmaRt controller to IP Interface, single Cat 5 socket)	PR0944 DIN
SmaRt network module, DIN Rail Mount (Single SmaRt controller to IP Interface, twin Cat 5 sockets)	PR0944 DUALDIN
SmaRt communications cable (2m)	PR0949
Din Rail Mount Single Modbus network module.	PR0945
Mercury 10 Way Network Module (Ten SmaRt controllers to IP interface)	PR0018



Note: The controller comes supplied with 2 x 1.5m NTC2K Air Probes in the box. This controller only supports NTC2K probes.

Front Display Features

When the controller is first powered up the display will show the type setting briefly, typ1 for example and then show controller status (REC for recovery for example) and then show the current display temperature.

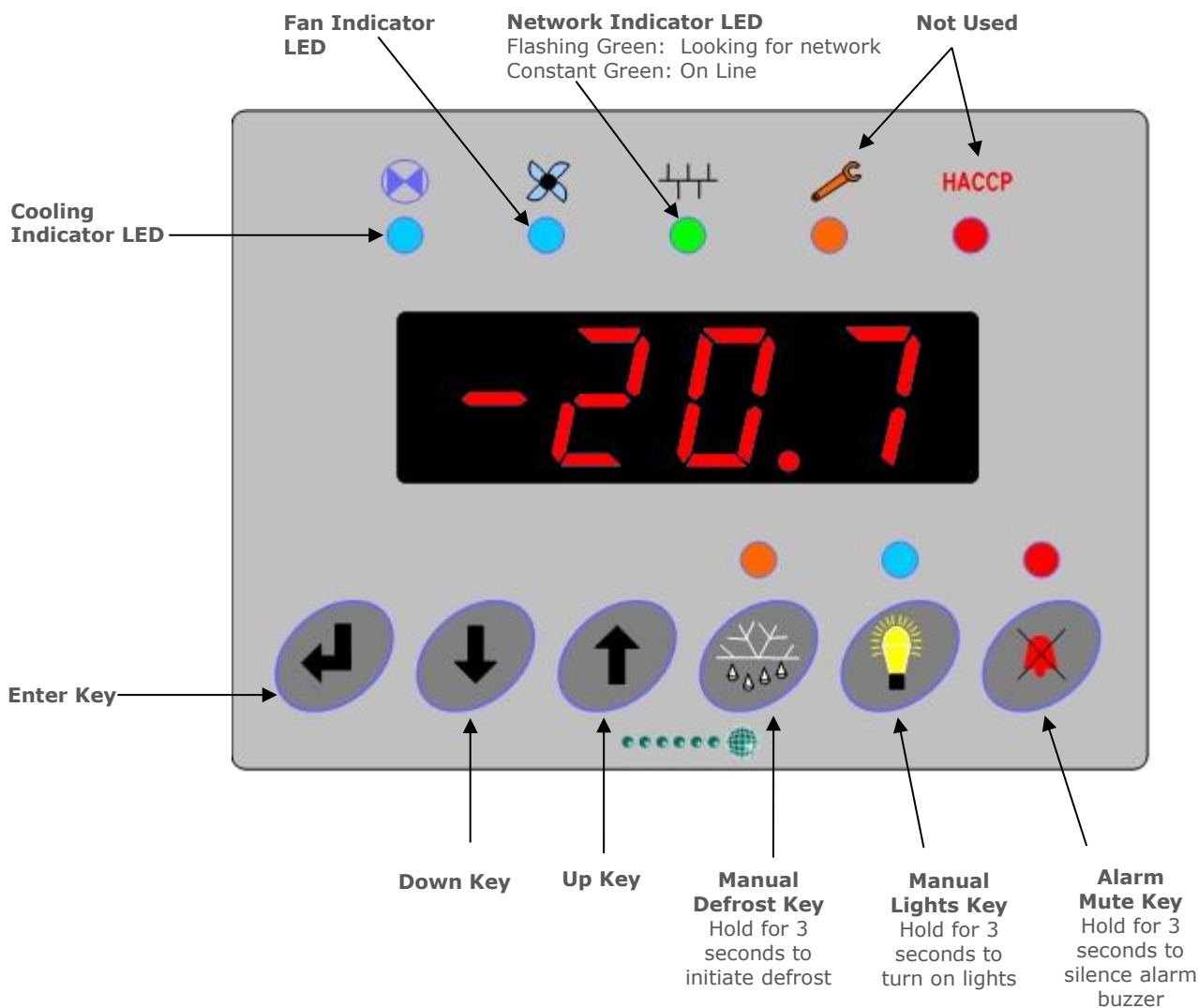

Input and Output Allocation Tables

The table below shows inputs and outputs when the controller is at factory default settings.

Input / Output	
Probe 1	Air on Temperature
Probe 2	Air off Temperature or Defrost Termination (User selectable)
Door Switch	Volt free, input is shorted when door is open.
Person Trapped	Volt free, input is shorted to activate trap alarm.
Relay 1	Cooling, compressor or liquid line valve (connect to normally closed)
Relay 2	Fans (connect to normally closed)
Relay 3	Lights (connect to normally closed), Defrost or Alarm (user selectable)
Relay 4	Defrost (connect to normally open), Lights or Alarm (user selectable)



Typical Connection Diagram

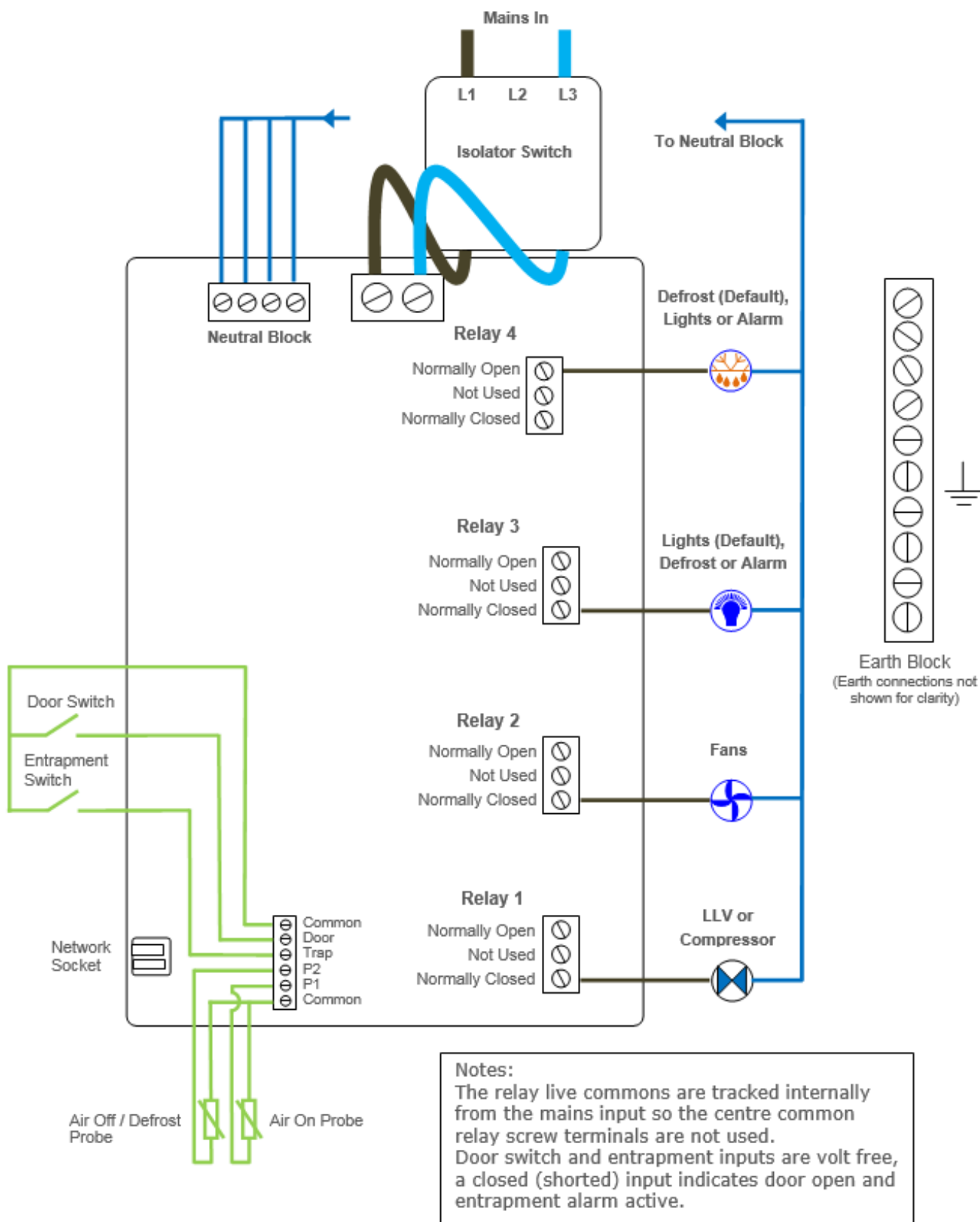

Quick Start Menu Map

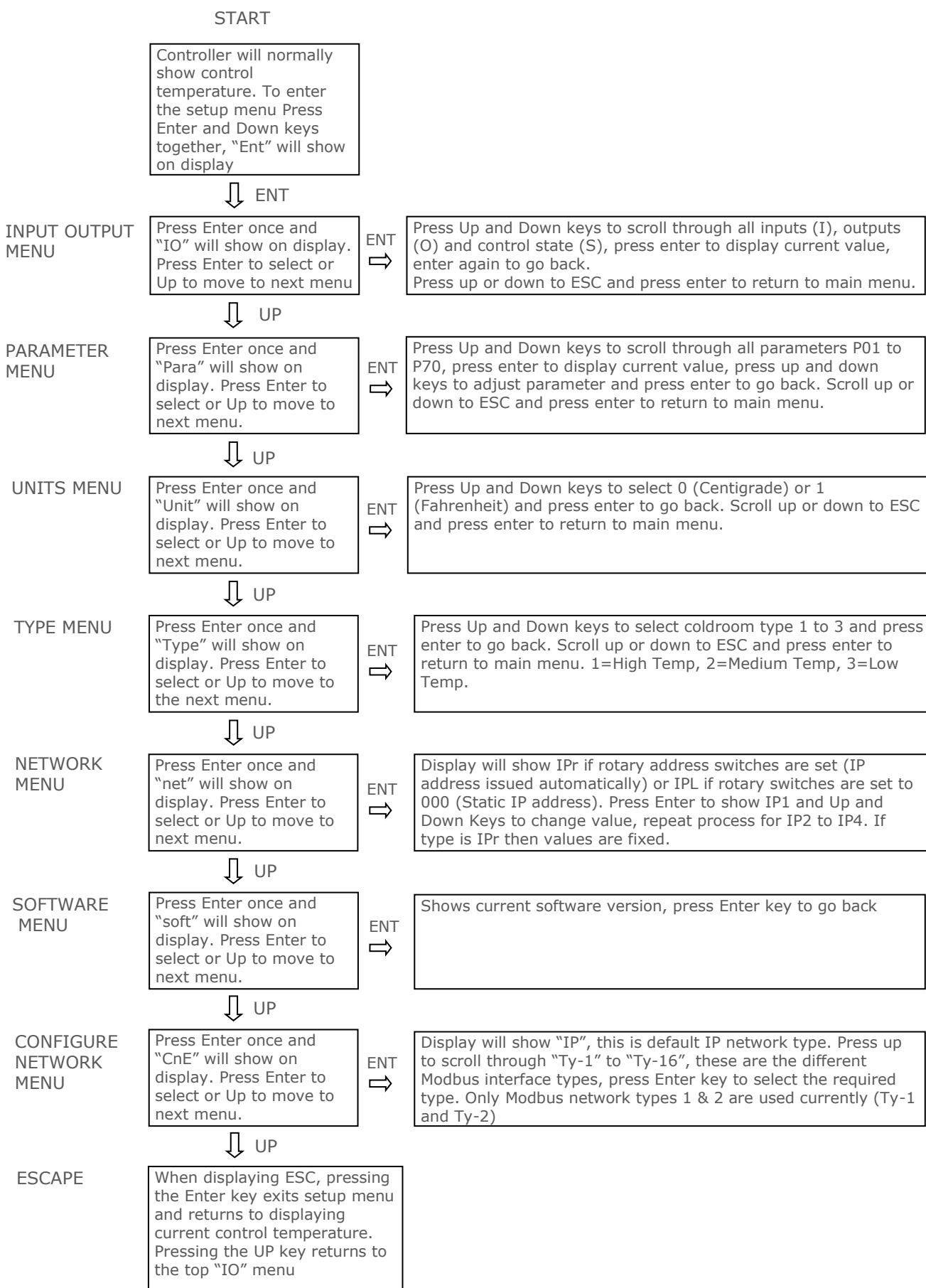

Access to the controller can be achieved several ways

- Through the front mounted buttons
- Access using RDM Smart communicator software running on a PC using a Smart comms cable. This requires a serial RS232 port on the PC so a USB to RS232 adapter will usually be required as well.
- Through the RDM Data Manager.
- Through a 3rd Party front end or Data Manager with a Modbus interface

Setup through front buttons



To enter setup mode, hold the Enter and Down buttons together, the message "Ent" appears on the display. Now press the Enter button again to enter the function menu. IO will be displayed. Scroll up or down to go through the list.

Setup Function Menu

Display	Option	Explained in Paragraph	Display	Option	Explained in Paragraph
IO	View Inputs / Outputs and States	Input / output table	net	Set/view network configuration	Network
PARA	Set/View Parameters	Set view parameters	soft	View software version	
Unit	Probe type and Celsius/Fahrenheit option	Set View Unit	CnEt	Configure Network	Network Selection
type	Set controller type	Controller Type	ESC	Exit Setup mode	

Recommended set-up method

If you are not connecting to a network and want to set up the controller through the buttons we recommend you use the following order from the function menu.

Type. Set/view controller type

- From the function menu scroll to select type, press enter
- Use the up/down buttons to scroll through types, 1 = High Temp, 2 = Medium Temp, 3 = Low Temp.
- Press enter.
- Scroll to select "ESC"
- Press enter

Controller type configuration is now set



Unit. Set/view temperature unit

- From the function menu select uni, press enter to view current setting
- Press up and down to select between 0 for Celsius and 1 for Fahrenheit, press enter to go back to function menu.

ParA. Set/view parameters (This can be achieved at the network front end)

- From the function menu scroll to select ParA
- Pressing Enter while ParA is displayed will enter the parameter menu. The first parameter option will be displayed as P-01. Pressing the Up or Down button will present the other parameter options P-02, P-03 etc. See the parameter list below to find what parameter number corresponds to which actual parameter. Pressing the Enter button will show the current value of the selected parameter. Press Up or Down to modify the value and press Enter again to save the value. The parameter list number will be displayed again. Two other options are present in the parameter menu – dFLt and ESC. Selecting ESC will exit setup mode. Selecting dFLt will reset all parameters back to the default values for the current type of controller.

Parameter Tables

Number	Parameter	Range	Step	Units	Default Type 1 HT	Default Type 2 MT	Default Type 3 LT
P-01	Cut-in Temperature	-49 to 40 (-56.2 to 104)	0.1	Deg C (F)	12	0	-20
P-02	Cut-in Diff	-49 to 40 (-56.2 to 104)	0.1	Deg	1.5	1.5	1.5
P-03	Control Weight	0 to 100	1	%	50	50	50
P-04	Probe 2 Select	0 = Air Off, 1 = Defrost	1		0	0	0
P-05	Relay 3 Select	0 = Lights, 1 = Defrost, 2 = Alarm	1		0	0	0
P-06	Relay 4 Select	0 = Lights, 1 = Defrost, 2 = Alarm	1		1	1	1
P-08	Door Closes Valve	0 = No, 1 = Yes	1		0	0	0
P-09	Door Stops Fan	0 = No, 1 = Yes	1		0	0	0
P-10	Door alarm delay	0 - 99	1	min:sec	20:00	20:00	20:00
P-11	Trap Stops LLV/Fans	0 = No, 1 = Yes	1		0	0	0
P-12	Ctrl Fail On/Off	0 - 99	1	min:sec	5	5	5
P-28	Buzzer	0 = Off, 1 = On	1		0	0	0
P-29	Display Pin	0 - 999	1		0	0	0
P-30	OT/UT alarm dly	0 - 99	01:00	min:sec	20:00	20:00	20:00
P-31	Under Temp Alm	-49 to 40 (-56.2 to 104)	1	Deg C (F)	4.0	-2.0	-30.0
P-32	Over Temp Alm	-49 to 40 (-56.2 to 104)	1	Deg C (F)	18.0	5.0	-15.0
P-40	Defrost Mode	0 = Local, 1 = Remote	1		0	0	0
P-41	Defrost Interval	0 - 120	1	Hours	4	4	4
P-42	Pump Down Time	0 - 99	01:00	min:sec	0	0	0
P-43	Defrost Length	0 - 99	01:00	min:sec	20:00	20:00	20:00
P-44	Defrost Skip Time	0 - 99	01:00	min:sec	0	0	0
P-45	Def. Term. Temp	-49 to 40 (-56.2 to 104)	1	Deg C (F)	18.0	10.0	15.0
P-46	Drain down time	0 - 99	01:00	min:sec	02:00	02:00	02:00
P-47	Recovery Time	0 - 99	01:00	min:sec	30:00	30:00	30:00
P-60	Fans in Defrost	0 = Off, 1 = On	1		1	1	1
P-61	Fan Delay Mode	0 = Time 1 = Temp	1		0	0	0
P-62	Fan Delay Time	0 - 99	01:00	min:sec	00:00	00:00	00:00
P-63	Fan Delay Temp	-49 to 40 (-56.2 to 104)		Deg C (F)	15.0	5.0	-5.0
P-64	Fans Temp Mode	0 = Off 1 = Temperature 2 = Over-temperature 3 = Temp/OT	1	0	0	0	0
P-65	Fans Off Temp	-49 to 40 (-56.2 to 104)	0.1	Deg C (F)	20.0	8.0	-10.0
P-66	Fan Control	0 = Off. 1 = Run. 2 = Pulse	1	0	0	0	0
P-67	Fan Pulse On	0 - 99	01:00	min:sec	5	5	5
P-68	Fan Pulse Off	0 - 99	01:00	min:sec	5	5	5
P-70	Timer Mode	0 = Local, 1 = Remote			0	0	0
dFLt	Restore default values						



Parameter Descriptions

Number	Parameter	Description
P-01	Cut-in Temperature	Temperature at which the LLV or compressor will switch on.
P-02	Cut-in Diff	Differential temperature below the cut-in temperature. The LLV or compressor switches off when below this temperature
P-03	Control Weight	Percentage of the Air-On temperature that is used to calculate the control temp. The remaining percentage will be used on the Air-Off temperature. This only applies if probe 2 is set to air off (P-04) Example, P-03 set to 30%, Control temp = 30% Air-on + 70% Air-off
P-04	Probe 2 Select	Allows probe 2 to be selected as an air off probe or defrost termination probe.
P-05	Relay 3 Select	Allows relay 3 to be used as lights, defrost or alarm.
P-06	Relay 4 Select	Allows relay 4 to be used as lights, defrost or alarm.
P-08	Door Closes Valve	This parameter is used to close the LLV or stop the compressor if the door opens.
P-09	Door Stops Fan	This parameter is used to stop the fans if the door opens
P-10	Door alarm delay	Delay after the door open input is activated before the alarm occurs. Fans and cooling will also return to normal operation if set to stop when the door opens (P08 & P-09) once the door alarm delay has expired.
P-11	Trap Stops LLV/Fans	When the entrapment input is activated the cooling stops and fans are stopped. Normal operation resumes when the entrapment input is deactivated.
P-12	Ctrl Fail On/Off	This value is used in the event of a control probe fail, this is the value to which the LLV/compressor relay will be pulsed open/closed. For example if set to 2 minutes then the LLV will be open for 2 minutes and then closed for two minutes. This process will continue until the control probe fail has been rectified.
P-28	Buzzer	Allows the user to turn the local alarm buzzer off.
P-29	Display Pin	Feature used for restricting access to settings menu via controller display. '0' disables the feature. A pin can be set between 1 and 999. The pin must be entered to access the menus. On non-networked units, if the pin is lost, RDM technical can be contacted to assist retrieval.
P-30	OT/UT alarm dly	Delay for the over and under-temperature alarms
P-31	Under Temp Alm	Under temperature alarm set point. This alarm uses the control temperature
P-32	Over Temp Alm	Over temperature alarm set point. This uses the air off probe, if probe 2 is set to defrost then the air on probe will be used.
P-40	Defrost Mode	Allows the user to set the defrost mode to local (uses internal timer) or remote (requires a defrost schedule in the front end.
P-41	Defrost Interval	When defrost mode is set to "Local", this is the number of hours between defrosts.
P-42	Pump Down Time	Time period before the defrost min period to allow for a pump down
P-43	Defrost Length	Time maximum defrost time allowed if defrost termination temperature is not reached.
P-44	Defrost Skip Time	Time factor used in defrost skip. The previous defrost has to terminate before this value expires to allow the controller to skip a defrost.
P-45	Def. Term. Temp	Temperature at which, when reached by the defrost or air off probe, the defrost will terminate.
P-46	Drain down time	A period after defrost max to allow the draining of any surplus water.
P-47	Recovery Time	Cooling is switched on at the start of this period to allow the temperature to recover to the normal operating point. This period also inhibits the OT alarm. Note that if the temperature is still above the OT alarm setpoint when this period expires, an immediate OT alarm occurs; there is not a further alarm delay.
P-60	Fans in Defrost	Allows the user to set the fans on or off in defrost.
P-61	Fan Delay Mode	This parameter allows the fans start after a drain-down period to be delayed, either by time (P-62) or when the temperature point (P-63) is reached. This parameter uses the same probe strategy as the defrost termination.
P-62	Fan Delay Time	Time after a drain-down period before the fans start if P-61 is set to time
P-63	Fan Delay Temp	Temperature below which the fans start after a drain-down period when P-61 is set to temperature, a fan delay time must also be set as a safety limit before the delay temperature will operate.
P-64	Fans Temp Mode	Allows the user to set the fans to turn off when, either a pre-determined temperature is reached (P65) , When an over-temperature alarm is present or when either P65 is reached or an OT alarm is present
P-65	Fans Off Temp	Temperature for the above (P64) operation.



Number	Parameter	Description
P-66	Fan Control	This feature allows for coldroom fans to be stopped when the coldroom is down to temperature thus saving energy. Run – fans operate as per the normal control strategy. Pulse – When the LLV closes the fans will stop when the Fan Pulse On parameter (P-67) time expires. The fans then remain off for the Fan Pulse Off time (P-68). When the parameter Fan Pulse Off time expires the fans come back on for the Fan Pulse on time. The cycle then repeats. The fans resume normal operation if the LLV operates. The fans pulse on/off to ensure the circulation of air within the coldroom. Off – when the LLV closes the fans stay on for the Fan Pulse On (P-67) time before going off until the LLV next operates. Placement of the temperature control probes is important when using this feature
67	Fan Pulse On	The duration of the fans are pulsed on in Fan Control.
68	Fan Pulse Off	The duration of the fans are pulsed off in Fan Control.
70	Timer Mode	Sets the lighting schedule to local or remote (Front End Schedule)
dFLt	Restore default values	Restores all of the parameters to their default values

Lighting Control

Relays 4 & 5 can be set to switch lights (P-05 & P-06). When timer mode (P-70) is set to remote then the lights will be switched by a lighting schedule set in the Data Manager GP timer. The Data Manager the GP timer channel output type needs to be set to "General" and output channel set to "3".

When timer mode (P-70) is set to local then the lights will be operated when the door is opened or the lights override button is pressed for 3 seconds on the coldroom display.

Lights will switch on when door switch or entrapment alarm is activated regardless of timer mode.

Relay and screen states during defrost

State:	Pump Down	Defrost	Drain Down	Fan Delay	Recovery
Screen:	DEF	DEF	DEF	DEF	REC
Def LED:	On	On	Off	Off	Off
RLY 1 LLV or Compressor	Off	Off	Off	On	On
RLY 2 Fans (On in DF)	On	On	On	Off	On
RLY 2 Fans (Off in DF)	On	Off	Off	Off	On
RLY 3 or 4 Defrost Relay	Off	On (until termination temperature)	Off	Off	Off

CnEt

This section allows for the setup of either IP network (default) or Modbus RS485, this will affect the menus that are shown in Net menu in the next section.

When entering the CnEt menu, IP will be shown on the display, this is the default setting for communication with an IP network using Cat 5 cabling. Pressing the up and down keys selects 1 of 16 Modbus RS485 network configurations, the display will show Ty-1 to Ty-16, at present only types Ty-1 and Ty-2 are used, press the enter key to select the configuration required.

Ty-1 = Modbus 9600 Baud Rate, 8 Bit, No Parity, 1 Stop Bit.

Ty-2 = Modbus 9600 Baud Rate, 8 Bit, No Parity, 2 Stop Bits.

IP Network Configuration

This section is to setup the IP network address, the configure network (CnEt) parameter need to be set to IP (see above). In all instances, this must be done before the controller is plugged into the site network. The controllers have an auto-initialise function, which will automatically log the device onto the site network. If the wrong address has been entered onto the network, you will have to reset the controller address by setting the address to 00-0, and then re-enter the correct address. (You may have to deregister the wrong address from the home system as well).

When logging a SmaRt controller onto a Data Manager IP network you must first connect the controller to the SmaRt communications module.



Enter the controller function menu by pressing the enter and down keys together and then pressing the enter key once, IO will show on the display. Press the up and down keys to reach the net menu and press enter, the display will show one of two options IP-L or IP-r.

IP-L allows you to fix an IP address into the controller, which you would use when you are connecting the controllers onto a Data Manager front end using a static IP address.

IP-r allows you to give each controller on the system a unique number. This number is then allocated a dynamic IP address by the Data Manager's DHCP server.

IP-L

To configure the communication module for IP-L, set all three rotary switches to zero. The module should then be connected to the controller.

1. nEt. From the function menu you can now select nEt
 - Press enter and the display will show "IP-L", press enter
 - You can now set the address using the table below

Display	Option
IP-1	IP Address byte 1
IP-2	IP Address byte 2
IP-3	IP Address byte 3
IP-4	IP Address byte 4
nL	Network Mask Length
gt-1	Gateway Address byte 1
gt-2	Gateway Address byte 2
gt-3	Gateway Address byte 3
gt-4	Gateway Address byte 4
ESC	Exit network menu. N.B. this option must be selected to save any changes made in this menu

IP-r

To configure the communication module for IP-r, set the three rotary switches to give each controller a unique identifier. The module should then be connected to the controller and the network. nEt. From the function menu you can now select nEt

- Press enter and the display will show "IP-r", press enter
- You can now view only the address given by the DHCP server

To ease setup, a single network mask length value is used. If the address has been specified with a network mask value in dotted IP format e.g. 255.255.255.0 then the table below gives the conversion:

Mask	Length	Mask	Length	Mask	Length
		255.255.254.0	23	255.254.0.0	15
255.255.255.252	30	255.255.252.0	22	255.252.0.0	14
255.255.255.248	29	255.255.248.0	21	255.248.0.0	13
255.255.255.240	28	255.255.240.0	20	255.240.0.0	12
255.255.255.224	27	255.255.224.0	19	255.224.0.0	11
255.255.255.192	26	255.255.192.0	18	255.192.0.0	10
255.255.255.128	25	255.255.128.0	17	255.128.0.0	09
255.255.255.0	24	255.255.0.0	16	255.0.0.0	08

Note: The SmARt controller will only communicate automatically with Data Managers with firmware version V2.3 or above, older Data Managers will require a software upgrade patch installed, please contact RDM technical support for more details.



Viewing

Apart from setting up the controller, you can also view the status of the inputs and outputs and controller states.

From the function menu, select "I/O", press enter. You can now scroll through the IO table as set out below. Inputs and outputs that do not apply to a particular controller type will be greyed out.

Input / Output Table

Number	IO	Range* °C (°F)	Step	Units
I-01	Control Temp	-49 to 40 (-43.6 to 262)	0.1	Deg
I-02	Air On Probe	-49 to 40 (-43.6 to 262)	0.1	Deg
I-03	Air on / Defrost Probe	-49 to 40 (-56.2 to 262)	0.1	Deg
I-10	Door Sensor	0 (Closed) ,1 (Open)		
I-11	Person Trapped	0 (OK), 1 (Alarm)		
O-01	Liquid Line/Compressor	0 (Off), 1 (On)		
O-02	Fans	0 (Off), 1 (On)		
O-03	Defrost	0 (Off), 1 (On)		
O-04	Lights	0 (Off), 1 (On)		
O-05	Alarm	0 (Off), 1 (On)		
O-06	Setpoint Offset	-18 to 18	1.0	Deg
O-07	Last Defrost Type	0 (None), 1 (Display), 2 (Timed), 3 (Missed),4 (Network), 5 (Skipped)	1	
O-08	Last Defrost Length	00:00 to 03:00	00:01	hh:mm
O-09	Last Def. Ctrl Temp.	-49 to 40 (-43.6 to 262)	0.1	Deg
S-01	Control State	0 (Stabilise),1 (Normal), 2 (Defrost), 3 (Drain Down), 4 (Fan Delay), 5 (Recovery), 6 (OT Alarm), 7 (UT Alarm), 8 (Pump Down)	1	

Messages

The following alarms and messages can appear on the SmaRt coldroom controller display.

Display Message	System status	Display Message	System status
Prb Flt	Both probes are faulty	Door	Door open alarm
Flt	One Probe is Faulty	Trap	Entrapment Alarm
rEC	Control State in Recovery	CS	Caesium programming module is connected
dEF	Control Sate in Defrost	rxx	xx number of parameters received by Caesium programmer
AL	Control State in Alarm	txx	xx number of parameters transmitted by Caesium Programmer

Note: When a person trapped alarm occurs it now pulses for 2 seconds on, 1 second off to distinguish from all other alarms.



Network Alarms

The table below shows the text and associated type number that is sent to the system "front end". The type number is normally used to provide different alarm actions.

Alarm text	Type # (index)
Missed defrost	15
Probe 1 or 2 Faulty	6
Over temperature	4
Under temperature	5
Door Left Open	2
Person Trapped	1

Remote Commands

The following command can be used by a Data Builder program: -

Command	Value to send	Description	Conditions
Setpoint Command	+/-18	Is added to or subtracted from the setpoint	
Defrost Command	1	Initiates a defrost cycle	Defrost mode: remote
Case Off Command	5	Sets the controller to Case Off	
	0	Restores the controller from Case Off to Normal	

Use an "Analogue Out" block configured to the controller name and in the value field type Setpoint Command. Use a "Setting block" as the input to the "Analogue Out" block to send the Value.

In the example below, whatever value is set in the setting block, the control setpoint will be changed by that amount on HT01-2

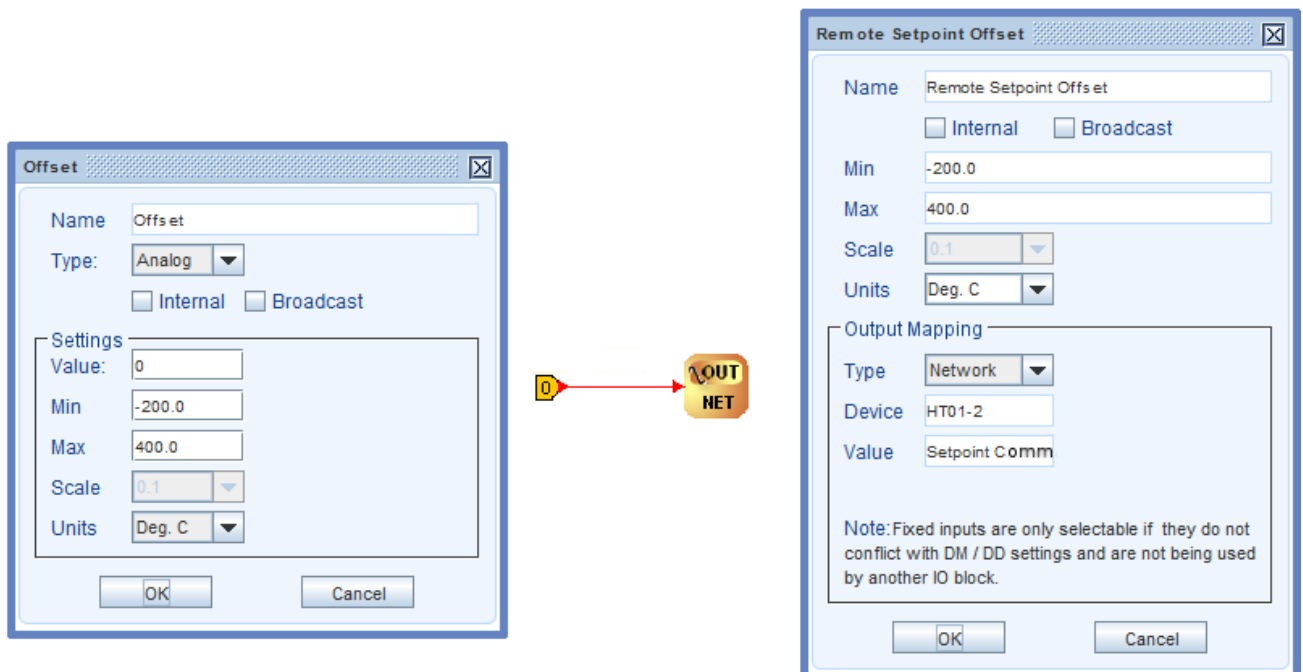

Network Interfaces

There are two DIN rail mounted IP interfaces available (PR0944 DIN and PR944 DUALDIN), these allow the controller to be connected to a Data Manager IP network. Both variants are powered by a mains (100-240Vac) to 5Vdc DIN rail mounted power supply, which is included.

The PR0944 DIN provides a single CAT5 socket for connection to the IP network whereas the PR0944 DUALDIN provides two CAT5 sockets which allows multiple interfaces to be connected in series, reducing the need for an IP network switch.

The DIN rail mounted RS485 Modbus interface (PR0945 DIN), allows the controller to be connected to a suitable Modbus compatible front end, such as a Data Manager.



Power Supply for PR0944



PR0944 DIN



PR0944 DUALDIN



PR0945

PR0944 Connections

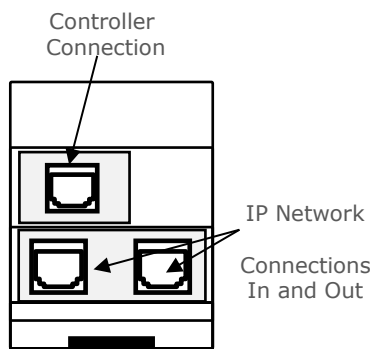

PR0944 DUALDIN Front

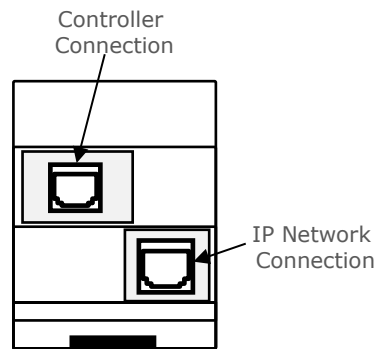

PR0944 DIN Front

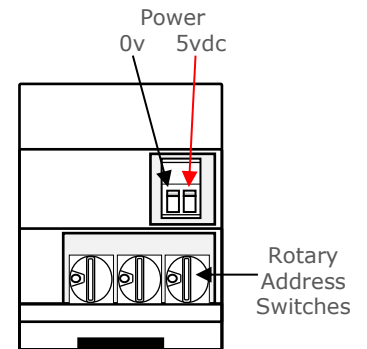

PR0944 DUAL / DUALDIN Back

PR0945 Connections

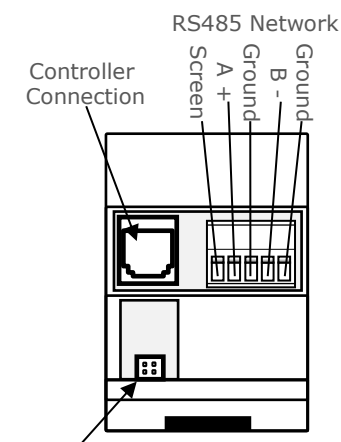

Connector for future use

PR0945 Front

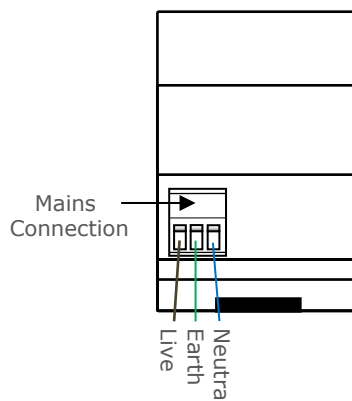

PR0945 Back

Note: The Smart controller is compatible with the PR0018 Mercury Hub however it should be noted that the maximum cable length from controller to hub is 2m.



Using the SmaRt Caesium Programming Adapter (PR0948)

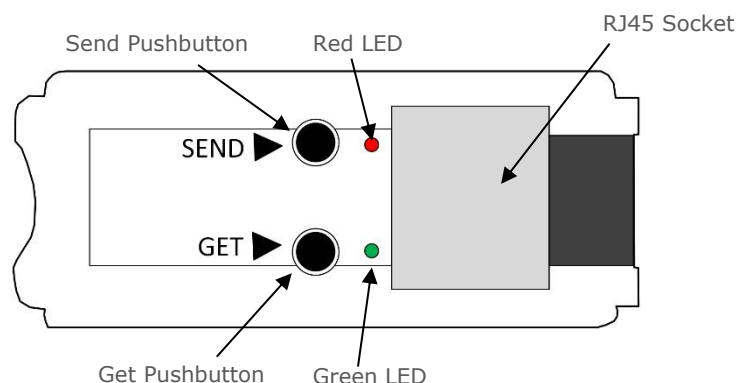

The Smart Caesium Programming adapter is a device designed to copy and store controller parameters from Smart controllers. These parameters can then be downloaded into similar controllers allowing a quick method of setting parameters in a batch of controllers whose settings have to be identical. (**Note:** This method is for same controller types only). The parameters can be uploaded to the Programming Module then locked in the module to prevent accidentally overwriting the uploaded parameters. The Module has an RJ45 socket to connect to the Smart network lead, two buttons for uploading, downloading, locking and unlocking parameters and two LEDs (One Green and one Red) to indicate the status or operation being carried out.

Connect the module to the network cable of the controller whose parameters have to be uploaded / downloaded:

The Green LED should be on steady. The Red LED should be off if the Caesium is blank and flashing at 1 second intervals if it has parameters already stored in it.

Note: The Red LED flashing at 2 second intervals indicates the module has parameters loaded and locked in Module.

To Upload parameters from Controller to Module:

Press the Upload (Get from Controller) button:

Green LED should now flash at 1 second intervals. Red LED should still be flashing – Release button.

Press Upload button again while Green LED is flashing. When the Red LED stays on steady – Release button.

Red LED stays on steady and Green LED flashes faster, after a short time both Red and Green LEDs flash simultaneously 4 times.

Coldroom display will show rxx where xx is the number of parameters received by the Caesium (r34 for example)

Parameters are now uploaded to module. Unplug module or lock parameters then unplug module.

Note: If parameters are locked in module and upload button is pressed the Red LED will still flash, but the Green LED will stay on steady indicating that parameters are locked and new parameters **cannot** be uploaded.

To Download parameters from Module to Controller:

Press the Download (Send to Controller) button:

Green LED should now flash at 1 second intervals. Red LED should still be flashing – Release button.

Press Download button again while Green LED is flashing. When the Red LED stays on steady – Release button.

Red LED stays on steady and Green LED flashes faster, after a short time both Red and Green LEDs flash simultaneously 4 times.

Coldroom display will show txx where xx is the number of parameters transmitted by the Caesium (t34 for example)

Note: LEDs **not** flashing 4 times indicates user is trying to download parameters to a controller with a different type, and parameters will **not** be sent to controller.

Parameters are now downloaded to controller. Unplug module.



To Lock Parameters in Module:

Press and hold both buttons at the same time.

Both LEDs will go off then flash simultaneously 3 times then go off again – Release both buttons at this point. Green LED will now come on steady again and Red LED will flash at **2 second** intervals.

Parameters are now locked in module.

To Unlock Parameters:

Press and hold both buttons at the same time.

Both LEDs will go off then flash simultaneously 3 times then go off again – Release both buttons at this point. Green LED will now come on steady again and Red LED will flash at **1 second** intervals again.

Parameters are now unlocked.

Note: Do not unplug module from controller while Green LED is flashing as parameter info is being transferred while LED is flashing.



Specification

Supply Voltage Range	100 – 240 Vac \pm 10%
Supply Frequency	50 – 60 Hz
Maximum supply current	40 Amps
Operating temperature range	+5°C to +50°C (41°F to 122°F)
Operating Humidity	80% maximum
Storage temperature range	-20°C to +65°C (-4°F to 149°F)
Environmental	Indoor use at altitudes up to 2000m (6570ft), pollution degree 1, voltage fluctuations not to exceed \pm 10% of nominal voltage.
Size	240mm (W) x 300mm (H) x 140mm (D) 9.45in (W) x 11.82in (H) x 5.51in (D)
Weight	1.6kg
Safety	EN61010 This device MUST be earthed
EMC	EN61326:2013
Ventilation	There is no requirement for forced cooling ventilation
The host equipment must provide a suitable external over-current protection device such as	Fuse: 40A 240 Vac Antisurge (T) HRC conforming to IEC 60127 Or MCB: 40A, 240 VAC Type C conforming to BS EN 60898
IP Rating	IP40
The host equipment must provide adequate protection against contact to hazardous live parts	
Maximum Relay Current Switched Output Voltage Relay Terminals	12.5 Amp resistive load, 8 Amp Inductive load, Cos Φ =0.4 Same as supply voltage. 2.5mm CSA
Relay Lifespan	2,000,000 operations switching 0.5A 250Vac 750,000 operations switching 2.5A 250Vac 300,000 operations switching 5A 250Vac 200,000 operations switching 12A 250Vac
Relay Fuse	12.5 Amp, type T, 6.3 x 32mm.
Circuit Board Fuse	1 Amp, type T, 5 x 20mm
DIN Rail Power Supply for PR0944	Input: 100-240 VAC, 0.88A Maximum Output: 5 VDC, 2.4A Maximum



Installation

Fixing

The Coldroom Panel has 4 fixing holes.

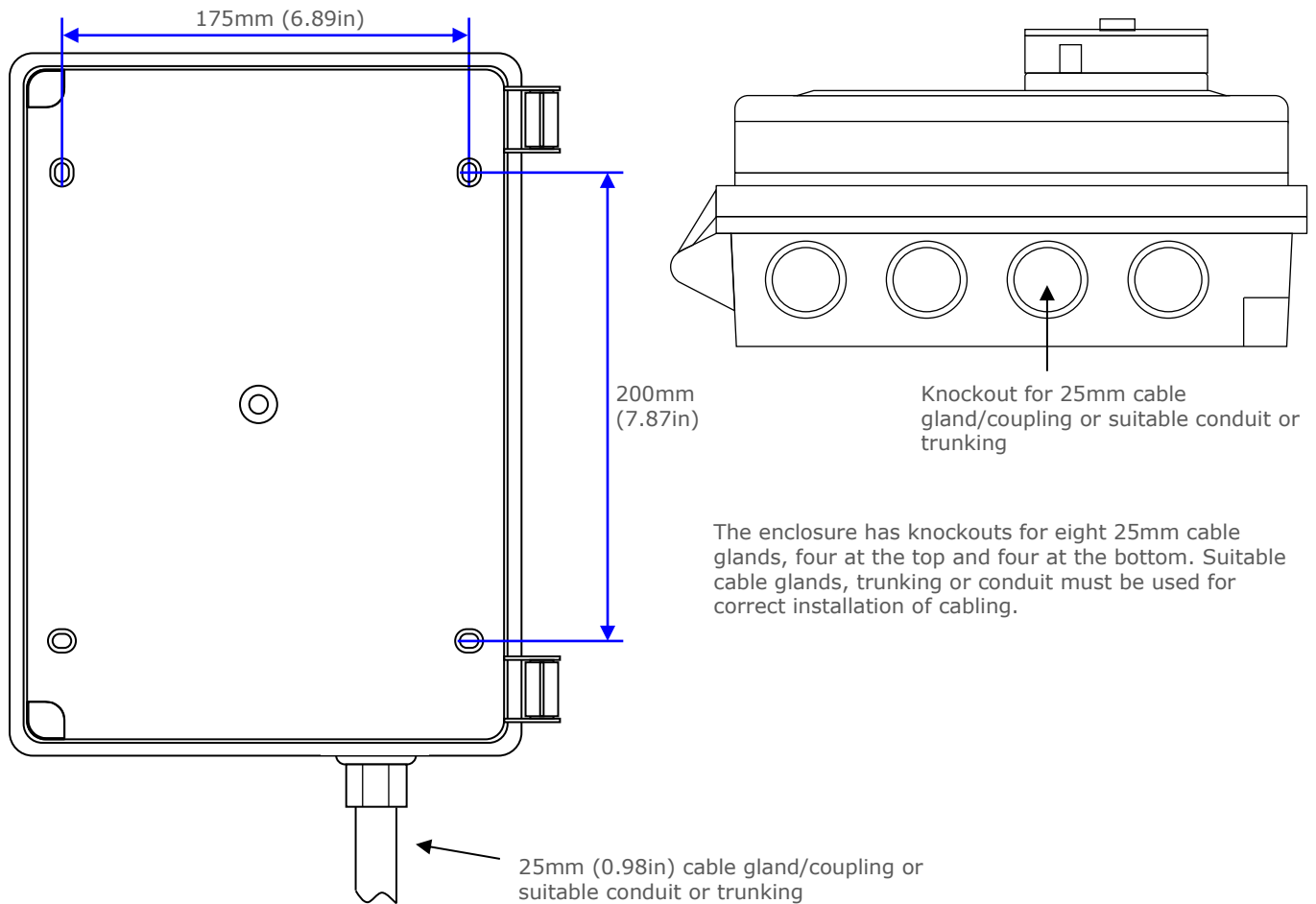

Cleaning

Do not wet the controller when cleaning. Clean the front by wiping with slightly dampened lint free cloth.

Disclaimer

The specifications of the product detailed in this document may change without notice. RDM Ltd shall not be liable for errors or omissions, for incidental or consequential damages, directly or indirectly, in connection with the furnishing, performance or misuse of this product or document.



Display Remote Mounting

The display section of the SmaRt Coldroom Panel can be removed for remote fixing. Unscrew the two front panel screws; take off the display front and then remove the 4 screws housing the display back onto the main enclosure. The display has an internal .4 meter cable* which requires to be uncoiled from its internal location. Ensure that all power is disconnected before this operation.

Mount the display back onto the surface using the centres below and then assemble the display front, securing with the 2 front panel screws.

*If the cable supplied is not suitable and a longer cable length is required, then a different length can be ordered using the following part numbers:

Part Number	Description
PR0129-0.75m	Display Cable - 0.75 metre
PR0129-1m	Display Cable - 1 metre
PR0129-5m	Display Cable - 5 metre

Display dimensions and fixing

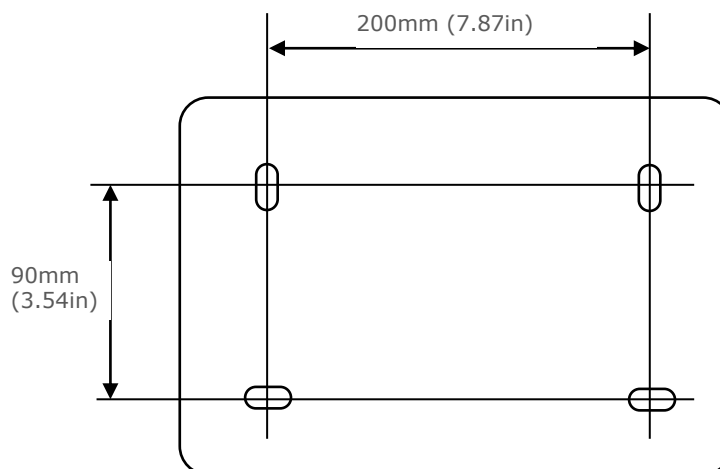
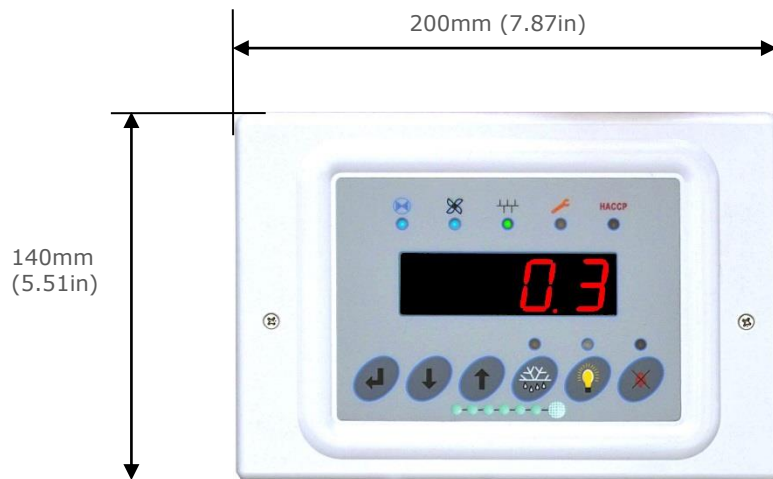

Appendix 1: Smart Controller Modbus® register address table

	Register	Name	Min	Max	Unit	Register Type	Item Type																			
Inputs & Outputs	0	Control temp.	-49 (-56.2)	40	C (F)	3 - Holding	Word	÷ 10	Invert	Extend																
	1	Air on Probe	-49 (-56.2)	40	C (F)	3 - Holding	Word	÷ 10	Invert	Extend																
	2	Air off/Def Probe	-49 (-56.2)	40	C (F)	3 - Holding	Word	÷ 10	Invert	Extend																
	3	Door Sensor	0 = Closed			3 - Holding	Word			Invert																
			1 = Open																							
	4	Person Trapped	0 = OK																							
			1 = Alarm																							
	5	Liq. Line Valve	0 = Off																							
			1 = On																							
	6	Fans	0 = Off																							
			1 = On																							
	7	Defrost Control	0 = Off																							
			1 = On																							
8	Lights	0 = Off																								
		1 = On																								
9	Alarm Healthy	0 = Off																								
		1 = On																								
10	Setpoint Offset	-18 (-56.2)	18	C (F)	3 - Holding	Word	÷ 10	Invert	Extend																	
11	Last Def. Type	0 = None			3 - Holding	Word																				
		1 = Display																								
		2 = Timed																								
		3 = Missed																								
		4 = Network																								
	5 = Skipped																									
12	Last Def. Length	0	5940	min:sec	3 - Holding	Word	× 60	Invert																		
13	Last Def. Temp.	-49 (-56.2)	40	C (F)	3 - Holding	Word	÷ 10	Invert																		
Parameters	14	Cut-in temp	-49 (-56.2)	40	C (F)	3 - Holding	Word	÷ 10	Invert	Extend																
	15	Cut-in diff.	-49 (-56.2)	40	C (F)	3 - Holding	Word	÷ 10	Invert	Extend																
	16	Control weight	0	100	%	3 - Holding	Word	× 1	Invert	Extend																
	17	Prb 2 Select	0 = Air			3 - Holding	Word	× 1		Invert																
			1 = Def																							
	18	Relay 3 Mode	0 = Lght																							
			1 = Def																							
		2 = Alm																								
	19	Relay 4 Mode	0 = Lght																							
			1 = Def																							
		2 = Alm																								
	20	Door Closes Valve	0 = No																							
			1 = Yes																							
	21	Door Stops Fan	0 = No																							
			1 = Yes																							
	22	Door Alarm Delay	0									5940	mm:ss	3 - Holding	Word	× 60	Invert									
	23	Trap Stops LLV/Fans	0 = No											3 - Holding	Word	× 1		Invert								
	1 = Yes																									
24	Ctrl Fail On/Off	0	5940																	mm:ss	3 - Holding	Word	× 60	Invert		
25	Buzzer	0 = Off																								
		1 = On																								
26	Display Pin	0	999		3 - Holding	Word	× 1	Invert																		
27	OT/UT alarm dly	0	5940	mm:ss	3 - Holding	Word	× 60	Invert																		
28	Under Temp Alm	-49 (-56.2)	40	C (F)	3 - Holding	Word	÷ 10	Invert																		
29	Over Temp Alm	-49 (-56.2)	40	C (F)	3 - Holding	Word	÷ 10	Invert																		
30	Defrost Mode	0 = Local			3 - Holding	Word	× 1		Invert																	
		1 = Remote																								



	Register	Name	Min	Max	Unit	Register Type	Item Type		
	31	Defrost Interval	0	120	hrs	3 - Holding	Word	x 1	Invert
	32	Pump Down Time	0	5940	min:sec	3 - Holding	Word	x 60	Invert
	33	Defrost Length	0	5940	min:sec	3 - Holding	Word	x 60	Invert
	34	Defrost Skip Time	0	5940	min:sec	3 - Holding	Word	x 60	Invert
	35	Def. Term. Temp	-49 (-56.2)	40	C (F)	3 - Holding	Word	÷ 10	Invert
	36	Drain Down Time	0	5940	min:sec	3 - Holding	Word	x 60	Invert
	37	Recovery Time	0	5940	min:sec	3 - Holding	Word	x 60	Invert
	38	Fans in Def	0 = Off 1 = On			3 - Holding	Word	x 1	Invert
	39	Fan Delay Mode	0 = Time 1 = Temp			3 - Holding	Word	x 1	Invert
	40	Fan Delay Time	0	5940	min:sec	3 - Holding	Word	x 60	Invert
	41	Fan Delay Temp	-49 (-56.2)	40	C (F)	3 - Holding	Word	÷ 10	Invert
	42	Fans Temp Mode	0 = Off 1 = Temp 2 = OT 3 = Temp/OT			3 - Holding	Word	x 1	Invert
	43	Fans Off Temp	-49 (-56.2)	40	C (F)	3 - Holding	Word	÷ 10	Invert
	44	Fan Control	0 = Off 1 = Run 2 = Pulse			3 - Holding	Word	x 1	Invert
	45	Fan Pulse On	0	5940	min:ss	3 - Holding	Word	x 60	Invert
	46	Fan Pulse Off	0	5940	min:ss	3 - Holding	Word	x 60	Invert
	47	Lights Mode	0 = Local 1 = Remote			3 - Holding	Word	x 1	Invert
States	48	Control State	0 = Stabilise						
			1 = Normal						
			2 = Defrost						
			3 = Drain						
			4 = Fan Delay						
			5 = Recovery						
			6 = Alarm						
			7 = Case Off 8 = Pump						
Commands	49	Defrost Command	0 = Normal						
			1 = Defrost						
			2 = ElecDf						
			3 = DefTerm						
			4 = Standby						
			5 = CaseOff						
	6 = FansOnly								
50	Setpoint Command	-18 (-18)	18 (18)	C (F)	3 - Holding	Word	÷ 10	Invert	
51	Case Off Command	0 = Normal							
		1 = Defrost							
		2 = ElecDF							
		3 = DefTerm							
		4 = Standby							
		5 = CaseOff 6 = FansOnly							

	Register	Name	Register Type	Item Type
Alarms	1	Missed Defrost	1 - Read Coils	Coil
	2	Probe 1 Faulty		
	3	Probe 2 Faulty		
	4	Case over temperature		
	5	Case under temperature		



Revision History

Revision	Date	Changes
1.0	14/07/2016	First Release
1.0a	17/08/2016	Part number updated.
1.0b	21/09/2016	Display Digits changed to red from blue to match hardware.
1.0c	23/09/2016	Isolator wiring amended to match current production version.
1.2	26/10/2016	When a person trapped alarm occurs it now pulses for 2 seconds on, 1 second off.
1.2a	07/02/2017	Controller is supplied with x2 NTC2K Air Probes.
1.2b	14/02/2017	Added ECA approval
1.2c	07/04/2017	Network interface details added.
1.2d	18/04/2017	Part numbers with internal network modules removed as not in production.
1.2e	20/07/2018	New documentation format.
1.2f	11/07/2019	Modbus registers added.



Group Offices

RDM Group Head Office
80 Johnstone Avenue
Hillington Industrial Estate
Glasgow
G52 4NZ
United Kingdom
+44 (0)141 810 2828
support@resourcedm.com

RDM USA
9441 Science Center Drive
New Hope
Minneapolis,
MN 55428
United States
+1 612 354 3923
usasupport@resourcedm.com

RDM Asia
Sky Park at One City
Jalan USJ 25/1
47650 Subang Jaya
Selangor
Malaysia
+603 5022 3188
asiatech@resourcedm.com



Visit www.resourcedm.com/support for more information on RDM solutions, additional product documentation and software downloads.

While every effort is made to ensure the information given within this document is accurate, Resource Data Management Ltd shall not be liable for errors or omissions, for incidental or consequential damages, directly or indirectly, in connection with the furnishing, performance or misuse of this product or document. All specifications are subject to change without notice. See www.resourcedm.com for terms and conditions of sales.