

Resource  
Data Management

# Mercury 2 & Intuitive Mercury Controller

Commissioning/User Guide  
Revision 2.6e



PR0710	PR0750-XXX
PR0711	PR0751-XXX
PR0720	PR0760-XXX
PR0721	PR0761-XXX

## Contents

The Mercury & Intuitive Range .....	5
Variants .....	5
Mercury Mk2 6-5E and 6-5M .....	5
Intuitive Mercury 6-5E and 6-5M .....	5
Compatible Displays .....	6
Configuration .....	6
Compatible Network Interfaces .....	6
Front Displays .....	7
Mercury 2 .....	7
Mercury Coldroom .....	8
Connections .....	9
Mercury Mk2 6-5E and 6-5M .....	9
Intuitive Mercury Controller .....	9
Intuitive Mercury Network Expansion Options .....	9
Intuitive Mercury EEV with Daughter Board Option .....	10
Daughter Board Connection Details .....	10
Ordering Information .....	10
Input and Output Allocation Tables .....	11
Input / Output allocation table for the 6-5M (Mechanical Expansion Valve or Compressor) .....	11
Input / Output allocation tables for 6-5E (Electronic Expansion Valve) .....	11
Switched Resistor Values .....	12
Setting up the controller .....	12
Setup through front buttons .....	12
Setup Function Menu (Common to all types) .....	12
Recommended set-up method .....	13
rtc. Real time clock (This will automatically synchronise on network systems) .....	13
type. Set/view controller type .....	13
PArA. Set/view parameters (This can be achieved at the network front end) .....	13
Unit. Set/view temperature unit and Probe type .....	13
Probe Types .....	13
Display .....	14
dtyP. Set / view display type .....	14
Parameter Tables .....	14
Parameter Descriptions .....	18



Please ensure all power is switched off before installing or maintaining this product.

Load Shedding .....	22
Superheat Options.....	22
EEV Control Using Pressure.....	22
Mercury Switch (PR0018-PHI) .....	23
Remote pressure Direct from a Plant Pack Controller.....	23
Local Daughter Card (Intuitive Mercury) .....	23
Maximum Operating Pressure (MOP) .....	23
Ref Weighting .....	23
Relay State and functional operation.....	24
Relay and screen states during defrost.....	24
Defrost Type (P-91) .....	24
Defrost Termination .....	24
Fan Delay after Defrost .....	24
Network Configuration .....	24
RS485 Legacy module / Intuitive Internal RS485 Network card .....	25
Wireless Mesh Communication Module .....	25
Fast Network Address Reset.....	25
IP Futura module / Intuitive Internal IP Network card .....	26
Mercury Switch .....	27
Viewing IO.....	27
Input / Output Table .....	27
Maximum and Minimum Control Temperature .....	28
Messages .....	29
Network Alarms .....	29
Modifying controller states.....	29
Fans Only "FanS".....	29
Case Off "CASE" .....	29
Lights Only "Ligt".....	30
Probe Offset.....	30
Remote Commands .....	30
Specification.....	31
Inputs .....	32
Switched Resistor Example Wiring .....	32
Installation .....	32
Fixing.....	32
Dimensions.....	33
Dimensions.....	33
Intuitive Mercury Mounting Instructions.....	34



Please ensure all power is switched off before installing or maintaining this product.

---

Cleaning .....	34
Disclaimer .....	34
Appendix 1 Defrost Cycles .....	35
Appendix 2 Trim Heater Control via Mercury/Intuitive Range .....	36
Revision History .....	36



Please ensure all power is switched off before installing or maintaining this product.

# The Mercury & Intuitive Range

## From Resource Data Management

For Version 2.4M & 3.0E

The Mercury Mk2 controller is primarily intended for use in refrigeration display cabinets or coldroom applications. It will switch the evaporator valve (LLV or EEV) based on the value of its temperature probe inputs. It has outputs to control lights, fans, suction valve, trim heaters and defrost control. The controller has many features some of which are energy saving; such as the "pulse trim heaters" parameter, see parameter section for further details. There are two hardware types of the Mercury Mk2 controller, one that has Relay 1 as a Solid State Relay for switching EEVs and the second type is an M version that has Relay 1 as an electro-mechanical relay for switching solenoid LLVs. These are named Mercury Mk2 6-5E and 6-5M respectively.

There is also a DIN rail mounted range, known as the Intuitive Mercury, which is designed to be used in a control panel or electrical tray. This range has the same features as the Mercury Mk2 controller with additional benefits such as higher rated relays, each protected by an integral fuse and fuse protection for the incoming power supply and the option for an internal daughter card to read suction pressure which can then be converted to the evaporator in temperature for use in calculating superheat. All connections are plug in socket and there are multiple network interfaces to choose from including Ethernet.

The controller supports PT1000, NTC2K, 470R, 700R, 3K, 5K, 6K, NTC2K25, NTC10K or NTC10K(2) temperature probes (note: probe types cannot be mixed).

## Variants

### Mercury Mk2 6-5E and 6-5M

Description	Part Number
Mercury Mk2 6-5M Mechanical expansion valve type, integral display.	PR0710
Mercury Mk2 6-5E Electronic expansion valve type, integral display.	PR0711
Mercury Mk2 6-5MR Mechanical expansion valve type, remote display.	PR0720
Mercury Mk2 6-5ER Electronic expansion valve, remote display.	PR0721

### Intuitive Mercury 6-5E and 6-5M

Description	Part Number
Intuitive Mercury 6-5M Mechanical expansion valve type, integral display.	PR0750
Intuitive Mercury 6-5E Electronic expansion valve type, integral display.	PR0751
Intuitive Mercury 6-5MR Mechanical expansion valve type, remote display.	PR0760
Intuitive Mercury 6-5ER Electronic expansion valve type, remote display.	PR0761
Intuitive Mercury 6-5E Electronic expansion valve type, integral display with 4-20mA Input Daughter Card	PR0751-IP-AiAo
Intuitive Mercury 6-5ER Electronic expansion valve type, remote display with 4-20mA Input Daughter Card	PR0761-IP-AiAo
Intuitive Mercury 6-5E Electronic expansion valve type, integral display with 0 – 10V Input Daughter Card	PR0751-IP-ViVo
Intuitive Mercury 6-5ER Electronic expansion valve type, remote display with 0 – 10V Input Daughter Card	PR0761-IP-ViVo



Please ensure all power is switched off before installing or maintaining this product.

## Compatible Displays

The following displays are compatible with the Mercury / Intuitive Remote Display Controllers (PR0720, PR0721, PR0760 and PR0761);

Description	Part Number
Mercury Remote Display with 5m cable	PR0325
Mercury Keyswitch Remote Display with 5m cable	PR0326
Mercury DIN Remote Display with 5m cable	PR0327
Mercury DIN Keyswitch Remote Display with 5m cable	PR0328
Mercury mk2 Remote Display with 5m cable	PR0725
Mercury Coldroom Display	PR0152

## Configuration

The controller gives you up to six configuration options;

Display Value	Mercury Mk2 / Intuitive 6-5M	Mercury Mk2 / Intuitive 6-5E
1	Integral controller HT	N/A
2	Integral controller LT	N/A
3	Remote piped case controller LT	Remote piped case controller LT
4	Remote piped case controller HT	Remote piped case controller HT
5	Coldroom controller LT	Coldroom controller LT
6	Coldroom controller HT	Coldroom controller HT

The controllers are delivered pre-configured: -

- 6-5M as an Integral controller HT (Type 1)
- 6-5E as Remote case controller LT (Type 3)

## Compatible Network Interfaces

Mercury and Intuitive Mercury controllers are capable of connecting to either a TCP/IP local area network, an RS485 Genus compatible network, an RDM wireless mesh network or they can be used in standalone mode with no network output. To connect to a network you must add the correct communications module. Connecting to any of these communication modules will automatically be detected on power up and will affect the set up screens available to you.

Description	Part Number
IP Futura (Single Mercury to IP Interface)	PR0016
RS485 Interface (Single Mercury to RS485 Interface)	PR0026
Mercury IP Switch (IP support for 10 controllers)	PR0018
Mercury IP Switch with Pressure/Humidity Inputs	PR0018-PHI
Wireless Mesh Interface (for single Mercury)	PR0730

The Intuitive Mercury Controller is supplied as standard with an internal RS232 network card, this allows connection to any of the above external network interfaces. Three alternative internal network cards are also available, these can be supplied factory fitted as an option or purchased separately as an interface kit.

Description	Part Number
Intuitive Internal IP Network Card Interface Kit	PR0770
Intuitive Internal RS485 Network Card Interface Kit	PR0771
Intuitive Internal Wireless Mesh Network Card Interface Kit	PR0772



Please ensure all power is switched off before installing or maintaining this product.

## Front Displays

### Mercury 2

The below display represents both the Mercury 2 internal display and the Mercury 2 (PR0725) remote display. The Mercury (Mk1) display will also be similar.

#### LED's: -

Valve (Relay 1) 

Fans (Relay 2) 

Lights (Relay 3) 

Defrost (Relay 5) 

On-Line 

- Off: No network attached
- Flashing: Attempting to Log on to network
- Steady: On-line

Service (See Parameter 18 for setup) 

Alarm 

HACCP 



#### Keys



Enter



Up



Down



Defrost

**Note:** Function keys illuminate when pressed, illumination is turned off 20 seconds after the key is used. Press and hold the defrost button to force a manual defrost



#### Main Display

4 character LED display, used to display temperature and status messages.

**Note** the Intuitive Mercury display is green in colour when lit







Please ensure all power is switched off before installing or maintaining this product.

## Mercury Coldroom







The below display represents the remote Mercury Coldroom (PR0152) remote display.

### LED's: -

- Valve 
- Fans 
- Lights 
- Defrost 
- On-Line 
  - Off: No network attached
  - Flashing: Attempting to Log on to network
  - Steady: On-line



- Service 
- Alarm 
- HACCP 

- ### Keys
- Enter 
  - Down 
  - Up 
  - Defrost Now 
  - Not used 
  - Not used 

**Note:** Press and hold the defrost button to force a manual defrost

### Main Display



4 character blue LED display, used to display temperature and status messages.



Please ensure all power is switched off before installing or maintaining this product.

## Connections

### Mercury Mk2 6-5E and 6-5M

Input and Output connections are made to the back of the controller, the RS232 communication port is on the side. The diagram shows the connection detail. Inputs and outputs are assigned according to the chosen configuration. See [Input/Output](#) tables for further details on connections.

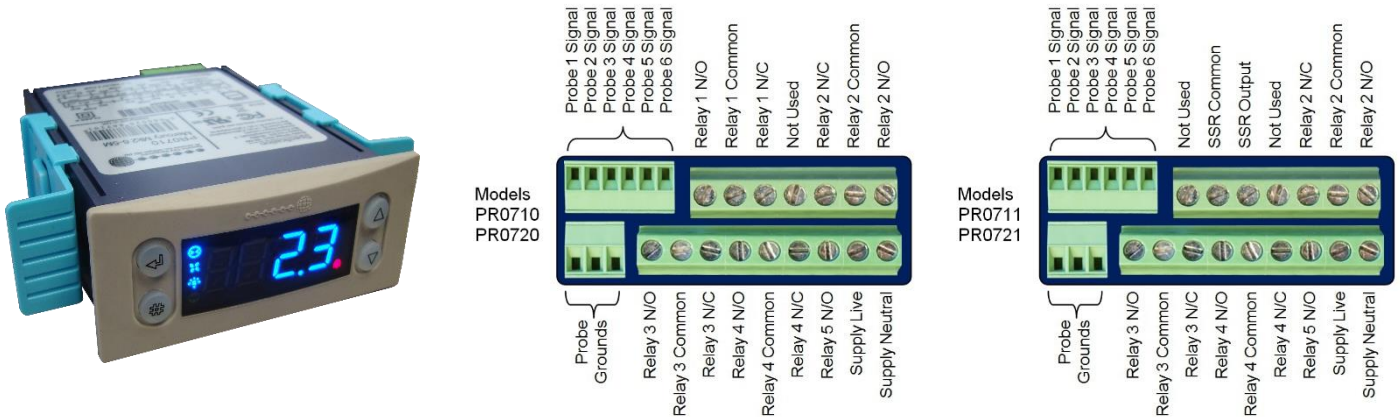

### Intuitive Mercury Controller

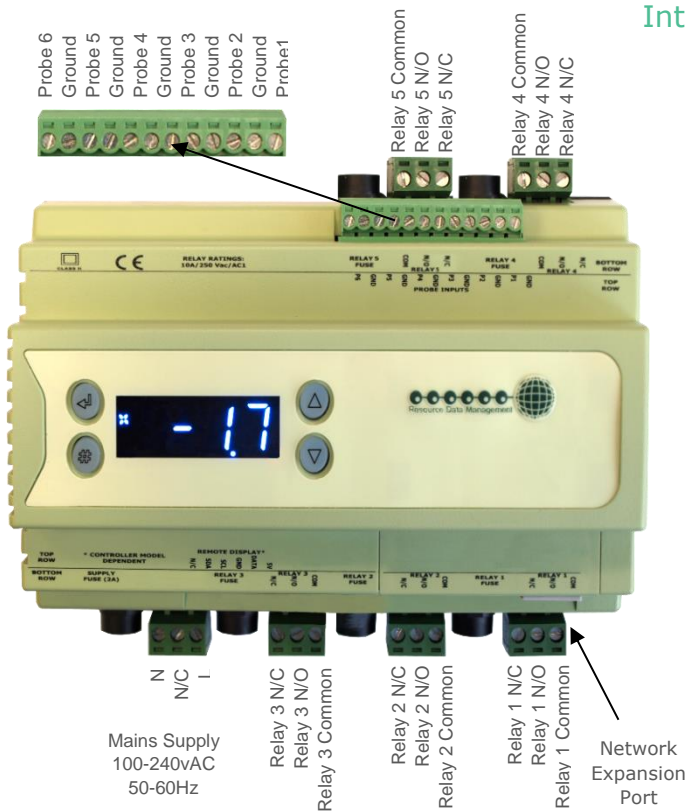

### Intuitive Mercury Network Expansion Options

#### RS232 Network Card (Default)

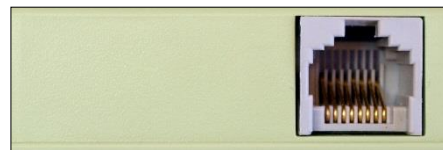

The Intuitive Mercury is supplied with an RS232 Network Card fitted as standard. Some example optional network cards are shown below

#### IP Network Card (PR0770)



Rotary Address Switches, Network Collision LED, Network Activity LED

#### RS485 Network Card (PR0771)



Ground, B-, A+, Screen, Network Activity LED

All inputs and outputs are plug and socket. The supply voltage and relay outputs have individual fuse protection.

PR0772 Wireless Mesh Option also available. The network interfaces work in the same way as their external counterparts.



Please ensure all power is switched off before installing or maintaining this product.

## Intuitive Mercury EEV with Daughter Board Option

The Intuitive Mercury EEV controller can be purchased with an optional daughter board to read suction pressure directly from a pressure transducer which enables it to calculate the superheat. To use this option, parameter P17 should be set to 4 or "LoBrd".

Please note the daughter boards are a factory fit option only and must be ordered with the controller.

Daughter Board Options	Connector Colour *
1 x 0-5V/0-10Vdc Input & 1 x 0-5V/0-10Vdc Output board	Blue
1 x 4-20mA Input & 1 x 4-20mA Output board	Black



Daughter card location (Optional)

\* Each daughter board comes with a colour coded connector as a visual indication.

## Daughter Board Connection Details

1 x 0-5V/0-10Vdc Input & 1 x 0-5V/0-10Vdc

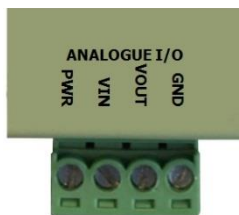

1 x 4-20mA Input & 1 x 4-20mA

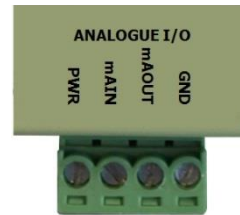

**Note:** "PWR" is a constant voltage output for external equipment, supply voltage is dependent on the board type, see the specification section for more details. GND is a common ground for all inputs and outputs.

## Ordering Information

When ordering a Mercury Intuitive controller the following ordering scheme can be used to purchase the desired hardware configuration. This ensures the controller ships with the optional hardware pre-fitted.

**PR07WX-Y-Z** Where **W**, **X**, **Y** and **Z** are selections from the tables below;

W	Description
5	Internal Display
6	Remote Display

X	Description
0	Mechanical Relay (LLV / Compressor)
1	Solid State Relay (EEV)

Y	Description
	RS232*
IP	IP Interface
RS485	RS485 Interface

Z	Description
	No Daughter Card**
Vi/Vo	1 x 0-5V/0-10Vdc Input & 1 x 0-5V/0-10Vdc Output
Ai/Ao	1 x 4-20mA Input & 1 x 4-20mA Output

\* Fitted by default.

\*\* If no daughter card required leave field blank

**Example** – To order an SSR, remote display variant, with a built in IP module and a 4 – 20mA board use the following part number;

PR0761-IP-AiAo

**Note:** The Intuitive can also be ordered in a Non-Fused version. To order this, add 'NF';

PR0761 NF -IP-AiAo



Please ensure all power is switched off before installing or maintaining this product.

## Input and Output Allocation Tables

The following tables indicate; on a controller type basis, the functions of the inputs and outputs. Also shown are the digital inputs that are derived by switching in a fixed value resistor across the input.

### Input / Output allocation table for the 6-5M (Mechanical Expansion Valve or Compressor)

TYPE	Integral Case Types 1&2	Remote Case Types 3&4	Coldroom Controller Types 5&6	Alarm Action	Plant Input (Switched Resistors)
Input 1	Air on Temperature	Air on Temperature	Air on Temperature	Yes	
Input 2	Air off Temperature	Air off Temperature	Air off Temperature	Yes	Man Trap alarm type 5 & 6
Input 3	Evaporator Temperature	Evaporator Temperature	Evaporator Temperature	No	Plant fault 1 or External Defrost Input
Input 4	Suction Line Temperature	Suction Line Temperature	Suction Line Temperature	No	Case Clean Switch
Input 5	Defrost Termination or Monitor probe (if used)	Defrost Termination or Monitor probe (if used)	Defrost Termination or Monitor probe (if used)	Conditional*	Plant fault 2 on types 1 & 2 Door switch on types 5 & 6
Input 6	Logging Probe (If fitted)	Logging Probe (If fitted)	Logging Probe (If fitted)	Conditional*	
Relay 1	Compressor A	Liquid Line Valve	Liquid Line Valve	N/A	
Relay 2	Fans	Fans	Fans	N/A	
Relay 3	Lights/Alarm Relay	Lights/Alarm Relay	Lights/Alarm Relay	N/A	
Relay 4	Compressor B	Suction Line Valve/Trim Heater/Alarm Relay/Remote Relay	Suction Line Valve/Alarm Relay/Remote	N/A	
Relay 5	Defrost Heater	Defrost Heater (N/O)	Defrost Heater (N/O)	N/A	

### Input / Output allocation tables for 6-5E (Electronic Expansion Valve)

TYPE	Remote Case Types 3&4	Coldroom Controller Types 5&6	Alarm Action	Plant Input (Switched Resistors)
Input 1	Air on Temperature	Air on Temperature	Yes	Plant fault 1 or External Defrost Input
Input 2	Air off Temperature	Air off Temperature	Yes	Case Clean Switch
Input 3	Evaporator Temperature	Evaporator Temperature	Yes	
Input 4	Suction Line Temperature	Suction Line Temperature	Yes	
Input 5	Defrost Termination or Monitor probe (if used)	Defrost Termination or Monitor probe (if used)	Conditional*	Door Switch on types 5 & 6
Input 6	Logging Probe (If fitted)	Logging Probe (If fitted)	Conditional*	Man Trap on types 5 & 6
Relay 1	Electronic Expansion Valve	Electronic Expansion Valve	N/A	
Relay 2	Fans	Fans	N/A	
Relay 3	Lights/Alarm Relay	Lights/Alarm Relay	N/A	
Relay 4	Suction Line Valve/Trim Heater/Alarm Relay/Remote Relay	Suction Line Valve/Alarm Relay/Remote	N/A	
Relay 5	Defrost Heater (N/O)	Defrost Heater (N/O)	N/A	

\* Alarm on monitor probe only if used



Please ensure all power is switched off before installing or maintaining this product.

## Switched Resistor Values

For PT1000 probes use 820 Ohm switched resistors. For NTC2K, NTC2K25 and 3K probes use 590 Ohm switched resistors. For 5K and 6K use 1K Ohm switched resistors. For NTC10K probes use 2k7 Ohm switched resistors. For NTC10K(2) probes use 2k2 Ohm switched resistors. The resistors used must have a tolerance of 1% or better and the resistor must have a power rating of 0.25W. For improved accuracy whilst using switched resistors RDM recommend resistors with 0.1% accuracy are used. Note the switched resistor features will **not** function when using 470R or 700R probes. When a resistor is switched across the appropriate input it signals to the Mercury to enable the switched resistor function described for that input whilst still recording the probe temperature on the input.

Temperature range for all probe types is -49°C to +128°C for probe inputs which do not have a secondary function (switched resistors). Inputs which have a secondary function are restricted to -42°C to +60°C. If the full temperature range is required on all inputs and no switch resistor features are needed then please see Switch Resistor parameter P-19

Note: switched resistors will operate in LT (Low Temperature) and HT (High Temperature) applications using PT1000, NTC2K or NTC2K25 probe types only. For all other probe types the switched resistor inputs will work in HT applications only.

## Setting up the controller

Access to the controller can be achieved several ways

- Through the front mounted buttons
- Direct access by PC or palm top into the rear comms port. This requires a software package available on the RDM website
- Through legacy front end panels on 485 networks
- Through the RDM Data Manager.
- Across an IP network. (Current controller IP address required)

### Setup through front buttons



To enter setup mode, hold the Enter and Down buttons together for approximately 3 seconds until the message "Ent" appears on the display. Now press the Enter button again to enter the function menu. IO will be displayed. Scroll up or down to go through the list.

### Setup Function Menu (Common to all types)

Display	Option	Explained in Paragraph	Display	Option	Explained in Paragraph
IO	View Inputs / Outputs and States	<a href="#">Input / output table</a>	nEt	Set/view network configuration	<a href="#">Network Configuration</a>
PArA	Set/View Parameters	<a href="#">Set view parameters</a>	SoFt	View software version	
Unit	Probe type and Celsius/Fahrenheit option	<a href="#">Set View Unit</a>	FANS	Toggle Fans Only mode	<a href="#">Fans</a>
diSP	Display whole units or decimal	<a href="#">Display</a>	CASE	Toggle Case Off mode	<a href="#">Case Off</a>
dtyP	Set/view display type	<a href="#">Display Type</a>	Ligt	Toggle Lights Only mode	<a href="#">Lights</a>
tyPE	Set/View Controller Type	<a href="#">Set/view controller type</a>	OFSt	Probe Offset	<a href="#">Probe Offset</a>
rtc	Set/view Clock (rtc = Real Time Clock)	<a href="#">Real Time Clock</a>	ESC	Exit Setup mode	



Please ensure all power is switched off before installing or maintaining this product.

## Recommended set-up method

If you are not connecting to a network and want to set up the controller through the buttons we recommend you use the following order from the function menu.

### rtc. Real time clock (This will automatically synchronise on network systems)

- a. Use the up or down buttons to scroll through the display until the display reads "rtc"
- b. Press enter. The display will show "t-1". press enter again
- c. Scroll hours up or down (0 – 23) press enter
- d. Use up button to select "t-2", press enter
- e. Scroll minutes up or down (0 – 59) press enter
- f. Repeat for t-3 (seconds 0 – 59)
- g. Repeat for t -4 (days up to 31)
- h. Repeat for t -5 (months up to 12)
- i. Repeat for t -6 (year up to 99)
- j. Use up button to display "ESC", press enter to display "rtc"

**Time clock is now set**

### type. Set/view controller type

- a. From the function menu scroll to select type, press enter
- b. Use the up/down buttons to scroll through case/coldroom configuration types. (see [configuration table on](#) page 4)
- c. Press enter.
- d. Scroll to select "ESC"
- e. Press enter

**Controller type configuration is now set**

### PArA. Set/view parameters (This can be achieved at the network front end)

- a. From the function menu scroll to select PArA
- b. Pressing Enter while PArA is displayed will enter the parameter menu. The first parameter option will be displayed as P-01. Pressing the Up or Down button will present the other parameter options P-02, P-03 etc. See the parameter list below to find what parameter number corresponds to which actual parameter. Pressing the Enter button will show the current value of the selected parameter. Press Up or Down to modify the value and press Enter again to save the value. The parameter list number will be displayed again. Two other options are present in the parameter menu – dFLt and ESC. Selecting ESC will exit setup mode. Selecting dFLt will reset all parameters back to the default values for the current type of controller.

## Unit. Set/view temperature unit and Probe type

From the function menu scroll to select 'Unit', press enter and the value will be displayed: -

### Probe Types

0 for PT1000 Celsius	10 for NTC2K25 Celsius
1 for PT1000 Fahrenheit	11 for NTC2K25 Fahrenheit
2 for NTC2K Celsius	12 for 5K Celsius
3 for NTC2K Fahrenheit	13 for 5K Fahrenheit
4 for 470R Celsius	14 for 6K Celsius
5 for 470R Fahrenheit	15 for 6K Fahrenheit
6 for 700R Celsius	16 for NTC10K Celsius
7 for 700R Fahrenheit	17 for NTC10K Fahrenheit
8 for 3K Celsius	18 for NTC10K(2) Celsius (USA NTC10K)
9 for 3K Fahrenheit	19 for NTC10K(2) Fahrenheit (USA NTC10K)

Use the up or down keys to select the units and press enter.

**This function is now complete**



Please ensure all power is switched off before installing or maintaining this product.

## Display

From the function menu scroll to and select diSP. Press enter and one of the following values will be shown: -

0. Controller display will show the whole number and tenths value of a temperature reading. (Default)
1. Controller display will show temperatures as a whole number.

## dtyP. Set / view display type

From the function menu scroll to and select dtyP. Press enter and one of the following values will be shown: -

0. Controller will be set to use a Mercury display.
1. Controller will be set to use a Coldroom display.

**Note:** The software defaults to 0 for the Mercury display. If using a Mercury 1 display, changing from type 1 to 0 needs to be done through the webpage and can't be done through the display.

## Parameter Tables

Not all parameters apply to all controller types, for example P-08 is Superheat reference which only applies to electronic expansion valve controllers (E types 3, 4, 5 & 6), this parameter will not appear if the controller is set up as a type 1 or 2 (integral case). In the following table, the type columns on the right hand side will be greyed out if that parameter does not apply to that controller type.

Number	Parameter	Range °C ( °F )	Step	Units	Default LT °C ( °F )	Default HT °C ( °F )	M Type 1&2	M Type 3&4	M Type 5&6	E Type 3&4	E Type 5&6
P-01	Cut-in Temp.	-42 to 30 (-43.6 to 86)	0.1	Deg	-20 (-4)	0.0 (32)		✓	✓	✓	✓
	Cut-in Temp. (Integral)	-42 to 30 (-43.6 to 86)	0.1	Deg	-20 (-4)	3.5 (38.3)	✓				
P-02	Diff.	0 to 10 (0 to 18)	0.1	Deg	2 (3.6)	1.5 (2.7)		✓	✓	✓	✓
	Diff. (Integral)	0 to 10 (0 to 18)	0.1	Deg	2.5 (4.5)	2.5 (4.5)	✓				
P-03	Control Weight	0 to 100	1	%	50	50		✓	✓	✓	✓
	Control Weight (Integral)	0 to 100	1	%	40	30	✓				
P-04	Display Weight	0 to 100	1	%	50	50		✓	✓	✓	✓
	Display Weight (Integral)	0 to 100	1	%	40	30	✓				
P-05	Lag Comp Delay	00:00 to 15:00	00:05	mm:ss	00:40	00:10	✓				
P-06	Anti SC Time	00:00 to 15:00	00:05	mm:ss	03:00	03:00	✓				
P-07	Lag Cut Out Diff	0 to 10 (0 to 18)	0.1	Deg	2.5 (4.5)	2.5 (4.5)	✓				
P-08	Superheat Ref	0 to 12 (7.2 to 21.6)	0.1	Deg	6 (10.8)	6 (10.8)				✓	✓
P-09	Response On	1 to 30	1		10	10				✓	✓
P-10	Response Off	1 to 30	1		10	10				✓	✓
P-11	Control Type	0 = EEV 1 = EET 2 = EEV/EET	1		0	0				✓	✓
P-51	EEV Minimum Opening	0 - 100%	1	%	10	10				✓	✓
P-52	Superheat Problem	0 - 12 °C (0 - 21.6 °F)	0.1	Deg	0	0				✓	✓
P-53	Superheat EEV Problem Opening	0 - 100%	1		10	10				✓	✓
P-54	Superheat EEV Problem Time	00:00 to 99:00	01:00	mm:ss	03:00	03:00				✓	✓
P-56	EEV Start Opening	0 - 100%	1	%	10	10				✓	✓
P-55	Average Valve Opening	0 - 100%	1	%	100	100				✓	✓
P-57	EEV Divide Value	0 - 100%	1		50	50				✓	✓
P-58	Div Size	0 (Off), 1(On)			0	0				✓	✓
P-12	Relay 4 Mode	0 = Suction Line	1		0	0		✓		✓	



Please ensure all power is switched off before installing or maintaining this product.

Number	Parameter	Range °C ( °F )	Step	Units	Default LT °C ( °F )	Default HT °C ( °F )	M Type 1&2	M Type 3&4	M Type 5&6	E Type 3&4	E Type 5&6
		1 = Trim Heater 2 = Alarm 3 = Remote 4 = Trim Hub									
	Relay 4 Mode (Coldroom)	0 = Suction Line 1 = Alarm 2 = Remote	1		0	0			✓		✓
P-13	Trim in Defrost	0 (Off), 1(On)			0	0		✓		✓	
P-14	Trim Level	0 to 100	1	%	100	100		✓		✓	
P-85	Key-switch Mode	0 = Case Off 1 = Fans only 2 = toggle	1		0	0	✓	✓	✓	✓	✓
P-87	Control Probe type	0 = Use Air on Probe 1 = Use Log Probe	1		0	0	✓	✓	✓	✓	✓
P-90	Resistor Case Off	0 (Disabled),1(Enabled)			0	0	✓	✓	✓	✓	✓
P-92	Fans temperature mode	0 = Off 1 = Temperature 2 = Over-temperature 3 = Temp/OT	1		0	0	✓	✓	✓	✓	✓
P-93	Fans Off Temperature	-42 to 30 (-43.6 to 86)	0.1	Deg	-10 (14)	8 (46.4)	✓	✓	✓	✓	✓
P-83	Fan Control	0 = Off 1 = Run 2 = Pulse	1		1	1			✓		✓
P-78	Fan Pulse On	00:00 to 99:00	01:00	mm:ss	05:00	05:00			✓		✓
P-79	Fan Pulse Off	00:00 to 99:00	01:00	mm:ss	30:00	30:00			✓		✓
P-15	Probe 5 Select	0 = Defrost, 1 = Monitor	1		0	0	✓	✓	✓	✓	✓
P-16	Relay 3 Mode	0 = Lights, 1 = Alarm	1		0	0	✓	✓	✓	✓	✓
P-17	Evap Select	0 = Local 1 = Rem1, 2 = Rem2, 3 = Rem3, 4 = LoBrd	1		0	0				✓	✓
P-97	Control Fail On/Off (Mechanical Valve)	00:00 to 10:00	01:00	mm:ss	00:00	00:00		✓	✓		
	Control Fail Valve Level (EEV)	0 - 100%	1	%	0	0				✓	✓
P-29	Probe 1 Resistor Function (EEV)	0 = Plant fault, 1 = External defrost	0.1	%	0	0				✓	✓
	Probe 3 Resistor function (Mechanical Valve)	0 = Plant fault, 1 = External defrost	1		0	0	✓	✓	✓		
P-18	Service Interval time	0 to 128	1	KHrs	60	60	✓	✓	✓	✓	✓
P-19	Switch Resistors	0 (Off), 1(On)			1	1	✓	✓	✓	✓	✓
P-77	Man Stop LLV/Fans	0 (Off), 1(On)	1		0	0			✓		✓
P-98	Lights Case Off	0 (Off), 1 (On), 2 (Unused)			0	0		✓		✓	
P-99	Load Shedding	0 (Off), 1 (Mode 1), 2 (Mode 2)	1		0	0		✓	✓	✓	✓
P-20	Alarm Delay	00:00 to 99:00	01:00	mm:ss	20:00	20:00	✓	✓	✓	✓	✓
P-21	Under Temp Alm	-49 to 60 (-56.2 to 140)	0.1	Deg	-30 (-22)	-2 (28.4)	✓	✓	✓	✓	✓
P-22	Over Temp Alm	-49 to 60 (-56.2 to 140)	0.1	Deg	-15 (5)	5 (41)	✓	✓	✓	✓	✓
P-23	Log Probe Type	0 (Off), 1 (Logging), 2 (Logging/Alarm)			Off	Off	✓	✓	✓	✓	✓



Please ensure all power is switched off before installing or maintaining this product.

Number	Parameter	Range °C ( °F )	Step	Units	Default LT °C ( °F )	Default HT °C ( °F )	M Type 1&2	M Type 3&4	M Type 5&6	E Type 3&4	E Type 5&6
P-24	Slug Log Probe	0 (Off), 1 (On)			Off	Off	✓	✓	✓	✓	✓
P-25	Log Alarm Delay	00:00 to 99:00	01:00	mm:ss	20:00	20:00	✓	✓	✓	✓	✓
P-26	Log UT Alarm	-49 to 60 (-56.2 to 140)	0.1	Deg	-35 (-31)	-1 (30.2)	✓	✓		✓	✓
	Log UT Alarm (Mechanical Valve Coldroom)	-49 to 60 (-56.2 to 140)	0.1	Deg	-30 (22)	-2 (28.4)			✓		
P-27	Log OT Alarm	-49 to 60 (-56.2 to 140)	0.1	Deg	-12 (10.4)	6 (42.8)	✓	✓		✓	✓
	Log OT Alarm (Mechanical Valve Coldroom)	-49 to 60 (-56.2 to 140)	0.1	Deg	-15 (5)	5 (41)			✓		
P-28	Monitor OT Alarm	-49 to 60 (-56.2 to 140)	0.1	Deg	20 (68)	20 (68)	✓	✓	✓	✓	✓
P-40	Defrost Mode	0 (Local), 1 (Remote), 2 (External)			Local	Local	✓	✓	✓	✓	✓
P-41	Defrost Start	00:00 to 23:59	00:01	hh:m m	01:00	01:00	✓	✓	✓	✓	✓
P-42	Defrosts per Day	0 to 8	1		6	6	✓	✓	✓	✓	✓
P-43	No Defrost Time	0 to 25	1	hours	8	8		✓	✓		
	No Defrost Time (Integral)	0 to 25	1	hours	8	5	✓				
	No Defrost Time (EEV)	0 to 25	1	hours	12	12				✓	✓
P-44	Def Terminate Temp.	-42 to 30 (-43.6 to 86)	0.1	Deg	14 (57.2)	10 (50)		✓	✓	✓	✓
	Def Terminate Temp. (Integral)	-42 to 30 (-43.6 to 86)	0.1	Deg	10 (50)	10 (50)	✓				
P-45	Def Min Time	00:00 to 99:00	01:00	mm:ss	05:00	05:00	✓	✓	✓	✓	✓
P-46	Def Max Time	00:00 to 99:00	01:00	mm:ss	24:00	24:00		✓	✓	✓	✓
	Def Max Time (Integral)	00:00 to 99:00	01:00	mm:ss	25:00	30:00	✓				
P-47	Drain Down	00:00 to 24:00	00:15	mm:ss	01:30	01:30		✓	✓	✓	✓
	Drain Down (Integral)	00:00 to 24:00	00:15	mm:ss	01:30	00:30	✓				
P-48	Recovery Time	00:00 to 99:00	01:00	mm:ss	30:00	30:00	✓	✓	✓	✓	✓
P-89	Pump Down Time	00:00 to 99:00	01:00	mm:ss	00:00	00:00	✓	✓	✓	✓	✓
P-86	Fan Delay mode	0 = Time 1 = Temp	1		0	0	✓	✓	✓	✓	✓
P-49	Fan Delay Time Types (Cabinet)	00:00 to 99:00	01:00	mm:ss	00:00	00:00		✓		✓	
	Fan Delay Time Types (Integral & Coldroom)	00:00 to 99:00	01:00	mm:ss	03:00	03:00	✓		✓		✓
P-88	Fan Delay Temp	-42 to 30 (-43.6 to 86)	0.1	Deg	-20 4) (-	0.0 (32)	✓	✓	✓	✓	✓
P-50	Fans In Defrost	0 (Off), 1 (On)			On	On	✓	✓		✓	
	Fans In Defrost (Coldroom)	0 (Off), 1 (On)			Off	Off			✓		✓
P-91	Defrost Type M & E	0 = Elec. 1 = Elce/Cin	1		0	0	✓	✓	✓	✓	✓
	Defrost Type (Integral)	0 = Elec. 1 = Gas. 2 = Elec Cin									
P-94	Defrost Hold	0 (Off), 1 (On)			Off	Off		✓	✓	✓	✓
P-95	Defrost Skip	0 (Off), 1 (On)			Off	Off	✓	✓	✓	✓	✓
P-96	Defrost Skip Time	00:00 to 99:00	01:00	mm:ss	12:00	12:00	✓	✓	✓	✓	✓
P-80	Door Alarm Delay	00:00 to 99:00	01:00	mm:ss	20:00	20:00			✓		✓
P-81	Door Closes LL	0 (No), 1 (Yes)			No	No			✓		✓



Please ensure all power is switched off before installing or maintaining this product.

Number	Parameter	Range °C ( °F )	Step	Units	Default LT °C ( °F )	Default HT °C ( °F )	M Type 1&2	M Type 3&4	M Type 5&6	E Type 3&4	E Type 5&6
P-82	Door Stops Fan	0 (No), 1 (Yes)			No	No			✓		✓
P-60	Lights Mode	0 (Local), 1 (Remote), 2 (Man Off), 3 (Man On)			Local	Local	✓	✓	✓	✓	✓
P-61	Sun Lights On	00:00 to 23:59	00:01	hh:m m	08:00	08:00	✓	✓	✓	✓	✓
P-62	Sun Lights Off	00:00 to 23:59	00:01	hh:m m	20:00	20:00	✓	✓	✓	✓	✓
P-63	Mon Lights On	00:00 to 23:59	00:01	hh:m m	08:00	08:00	✓	✓	✓	✓	✓
P-64	Mon Lights Off	00:00 to 23:59	00:01	hh:m m	20:00	20:00	✓	✓	✓	✓	✓
P-65	Tue Lights On	00:00 to 23:59	00:01	hh:m m	08:00	08:00	✓	✓	✓	✓	✓
P-66	Tue Lights Off	00:00 to 23:59	00:01	hh:m m	20:00	20:00	✓	✓	✓	✓	✓
P-67	Wed Lights On	00:00 to 23:59	00:01	hh:m m	08:00	08:00	✓	✓	✓	✓	✓
P-68	Wed Lights Off	00:00 to 23:59	00:01	hh:m m	20:00	20:00	✓	✓	✓	✓	✓
P-69	Thu Lights On	00:00 to 23:59	00:01	hh:m m	08:00	08:00	✓	✓	✓	✓	✓
P-70	Thu Lights Off	00:00 to 23:59	00:01	hh:m m	20:00	20:00	✓	✓	✓	✓	✓
P-71	Fri Lights On	00:00 to 23:59	00:01	hh:m m	08:00	08:00	✓	✓	✓	✓	✓
P-72	Fri Lights Off	00:00 to 23:59	00:01	hh:m m	20:00	20:00	✓	✓	✓	✓	✓
P-73	Sat Lights On	00:00 to 23:59	00:01	hh:m m	08:00	08:00	✓	✓	✓	✓	✓
P-74	Sat Lights Off	00:00 to 23:59	00:01	hh:m m	20:00	20:00	✓	✓	✓	✓	✓
P-30	Broadcast ID	0 to 999	1	-	0	0				✓	✓
P-31	Refrigerant	See Refrigerant Table Below	1	-	0	0				✓	✓
P-110	Ref Weight	0-100	1	%	0	0					
P-32	Pressure Units	0 = Absolute 1 = Gauge	1	-	0	0				✓	✓
P-33	Evap Offset**	0.0 to 5.0 (0 to 72)	0.1	-	0.0	0.0				✓	✓
P-34	Glide	-15.0 to 15.0	0.1	Deg	0.0	0.0				✓	✓
P-35	Trans Span	-3.4 to 180.0	0.1	Bar	13.8	13.8				✓	✓
P-36	Trans Offset	-3.4 to 180.0	0.1	Bar	0.0	0.0				✓	✓
dFLt	Restore defaults						✓	✓	✓	✓	✓

\* Transducer Span and Offset allows for the full range of the transducer to be used by the Mercury Controller.  
Span is the full range of the transducer  
Offset is the value below zero.

Example: Danfoss AKS 33 with range: -1 bar to 12 bar  
Span would be 190 (13 bar)  
Offset would be -15 (-1 bar)

\*\* If going from PSI to Bar and the Evap Offset parameter is above the limit of 5 bar then the controller will restart with the parameter reset to the default.



Please ensure all power is switched off before installing or maintaining this product.

## Refrigerant Table for P-31

No.	Gas	No.	Gas	No.	Gas	No.	Gas	No.	Gas
0	None	6	R401A	12	R407A	18	R507	24	R449A
1	R22	7	R401B	13	R407B	19	R717	25	R513A
2	R32	8	R401C	14	R407C	20	R290		
3	R134a	9	R402A	15	R500	21	R744		
4	R142B	10	R402B	16	R502	22	R407F		
5	R227	11	R404A	17	R503	23	R410A		

## Parameter Descriptions

Number	Parameter	Description
P-01	Cut-in Temp	Temperature at which the LLV or compressor will switch on.
P-02	Diff	Differential temperature below the cut-in temperature. The LLV or lead compressor switches off when below this temperature
P-03	Control Weight	Percentage of the Air-On temperature that is used to calculate the control temp. The remaining percentage will be used on the Air-Off temperature. Example; P-03 set to <b>30%</b> Control temp = <b>30%</b> Air-on and <b>70%</b> Air-off
P-04	Display Weight	As above, only applied to the display temperature.
P-05	Lag Comp Delay	Delay before the second compressor is switched on if the temperature is still above set-point. <b>Note:</b> The lead and lag compressors swap after each defrost to even the run times.
P-06	Anti-SC Time	Allows the user to set the compressor for a given number of starts/hour
P-07	Lag Cut Out Diff	Diff below the Cut-In Temp the lag compressor switches off. <b>Single Compressor Operation;</b> To disable compressor B operation and use only a single compressor for control set parameter P-07 to 0. This will allow the controller work with just one compressor (A) and ignore compressor B.
P-08	Superheat Ref	The controller will attempt to maintain this superheat value
P-09	Response on	Allows the user to speed up the EEV on time. With 30 providing the quickest response and 1 providing the slowest response.
P-10	Response off	Allows the user to speed up the EEV off time. With 30 providing the quickest response and 1 providing the slowest response.
P-11	Control Type	Allows the user to select either EEV control, EET control or EEV/EET control. <b>Note:</b> the Evaporator Temperature probe should be fitted to the coldest point in the evaporator. EEV uses the superheat as its main reference with the cabinet temperature as a secondary control. EET use the cabinet temperature as its main reference. EEV/EET uses cabinet temperature as the main control until the SH gets close to the SH reference point, then it switches to EEV control, it switches back to EET control when the SH reference is satisfied. <b>This parameter should always be left at default setting EEV and only ever changed under exceptional circumstances.</b>
P-51	EEV Minimum Opening	Sets the minimum valve opening level, during normal operation the valve will not go below this level. (Default 10%) <b>Note:</b> If used in conjunction with a Mercury Pressure Hub PR0018-PHI, remote pressure from Plant Pack or local pressure from a daughter card, then the Minimum value should be set at <b>0%</b>
P-52	Superheat Problem	Sets the point at which the algorithm will go to the "EEV Problem" state due to the superheat temperature. For example if this parameter is set to 0 Degrees and the Superheat value falls to 0 degrees or below, for the duration of P-54, then the controller will enter the superheat problem state. <b>Note:</b> The valve can also enter problem state if the control temperature is above setpoint, the valve is open but the cabinet / coldroom is not getting any colder. Before V2.5 software (EEV variant) this was fixed at 80% valve opening for two minutes, it now uses P-53 value.
P-53	Superheat EEV Problem Opening	Sets the valve open position when entering the "Superheat EEV Problem" state.
P-54	Superheat EEV Problem Time	Sets the time the algorithm stays in the "Superheat EEV Problem" state.
P-56	EEV Start Opening	Sets the valve opening % which is used immediately after the device is powered on.
P-55	Average Valve Opening	Normally the valve during recovery will open to the last average position. This setting allows for that value to be reduced by said percentage. For example if the average valve opening is



Please ensure all power is switched off before installing or maintaining this product.

Number	Parameter	Description
		calculated as 80% and P-55 is set to 50% then the valve will open at 40%.
P-57	EEV Divide value	This parameter only takes effect when the controller is used in conjunction with a Mercury Switch pressure application or a pressure transducer is connected directly to the controller. When the pressure exceeds the MOP alarm threshold the controller reduces the maximum valve opening to this percentage. For example if this parameter is set to 50% and the MOP alarm is generated then the maximum valve opening will be limited to 50%. <b>Note:</b> P-51 EEV Minimum opening overrides the valve output operation and the valve will not pulse below this setting.  Please see <b>MOP</b> note. <b>Note</b> parameters P-51 through to P-57 should not be altered without first understanding the effects they may have on the case operation. If incorrectly set they may have undesired affects.
P-58	Div Size	If this parameter is set to On then the EEV Divide Value set in P-57 will be used permanently and will restrict the opening of the valve at all times. This parameter may be used to reduce valve opening when an oversized valve is in use.
P-12	Relay 4 Mode	Relay 4 can be a Suction, Trim Heater, Alarm, Remote or Trim Hub relay. <ul style="list-style-type: none"> <li>➤ Suction – set for Suction Line Valve operation.</li> <li>➤ Trim Heater – set as trim relay which pulses in accordance with P-14 or the Data Manager energy feature trim control.</li> <li>➤ Alarm – The alarm relay is energised for no alarm. Use the NC and Common for “Loop make” on alarm or use the NO and Common for “Loop break” on alarm.</li> <li>➤ Remote – The relay is available for remote purposes such as the Data Manager GP timer channel or Data Builder software.</li> <li>➤ Trim Hub – Relay is pulsed in accordance with the Trim Control feature present in the Mercury Switch (PR0018-PHI). See the Mercury switch (PR0018) user document for further details.</li> </ul>
P-13	Trim in Defrost	Allows the trims to be off or on during a defrost.
P-14	Trim Level	Sets a percentage level, of a 5-minute period, to pulse the trim heater relay off/on. Example: - P-14 set to 50% = 2.5 minutes on, 2.5 minutes off. If the controller is networked to a Data Manager operating the energy feature Trim Control then the Data Manager feature will override this parameter setting. Please refer to the Data Manager user document for further details. <b>Note</b> the trims are turned off when an over temperature alarm occurs.
P-85	Key-switch Mode	Allows the keys switch to be: - <ul style="list-style-type: none"> <li>➤ Single turn for case off (Case off mode)</li> <li>➤ Single turn for Fans only (Fans Mode)</li> <li>➤ Single turn for case off, double turn for fans only (Toggle mode)</li> </ul>
P-87	Control Probe type	Switches between using the air-on probe and the Logging probe. Note the control and display temperature will still be a derivative of the weighted Average of the control probe + Air-off probe
P-90	Resistor Case Off	Turns on/off the switched resistor case off function
p-92	Fans temperature mode	Allows the user to set the fans to turn off when: - <ul style="list-style-type: none"> <li>➤ A pre-determined temperature is reached (P93)</li> <li>➤ When an over-temperature alarm is present</li> <li>➤ When either P93 is reached or an OT alarm is present</li> </ul>
P-93	Fans Off Temperature	Temperature for the above (P92) operation. <b>Note</b> the defrost termination probe is the source of the temperature reading used in this feature. If the defrost termination probe isn't fitted then a similar process to P-44 is used.
P-83	Fan Control	This feature allows for coldroom fans to be stopped when the coldroom is down to temperature thus saving energy. This feature is present in both the M and E software. <ul style="list-style-type: none"> <li>➤ Off – When the LLV closes the fans stay on for the Fan Pulse On (P-78) time before going off until the LLV next operates.</li> <li>➤ Run – fans operate as per the normal control strategy.</li> <li>➤ Pulse – When the LLV closes the fans will stop when the Fan Pulse On parameter (P-78) time expires. The fans then remain off for the Fan Pulse Off time (P-79). When the parameter Fan Pulse Off time expires the fans come back on for the Fan Pulse on time. The cycle then repeats. The fans resume normal operation if the LLV operates. The fans pulse on/off to ensure the circulation of air within the coldroom.</li> </ul> Placement of the temperature control probes is important when using this feature
P-78	Fan Pulse On	The duration of the fans are pulsed on in Fan Control.
P-79	Fan Pulse Off	The duration of the fans are pulsed off in Fan Control.
P-15	Probe 5 Select	This input can be used as a defrost termination probe (default) or as a monitor probe with an OT alarm level (P-28)
P-16	Relay 3 mode	This changes the function of relay 3 from Lights (default) to an alarm relay. The alarm relay is



Please ensure all power is switched off before installing or maintaining this product.

Number	Parameter	Description
		energised for no alarm. Use the NC and Common for "Loop make" on alarm or use the NO and Common for "Loop break" on alarm.
P-17	Evap Select	This allows the control algorithm to use a remote temperature input in place of the evaporator in value. In the event of no remote value being received, the control algorithm will revert to using the evaporator in probe value until the remote value is restored.  Please see: <a href="#">Superheat Options</a>
P-97	Control Fail Valve Value	This value is used in the event of a control probe fail; In the EEV control algorithm the valve will remain at this opening until the probe fault has been cleared. <b>Please note</b> the incorrect setting of this value may result in flood back causing damage to the pack compressors. Do not adjust this parameter if you are unsure of the consequences. In M software this is the value to which the LLV/compressor relay will be pulsed open/closed. For example if set to 2 minutes then the LLV will be open for 2 minutes and then closed for two minutes. This process will continue until the control probe fail has been rectified.
P-29	Probe 1 or Probe 3 Resistor	Selects whether the switched resistor invokes either a Plant fault or an External Defrost. If E software then probe input 1 is used. If M software then probe input 3 is used.
P-18	Service Interval Time (Run Hours)	Time (in 1000 x hours) before the service icon (Spanner icon) comes on. The Run Hours timer increments based on the number of hours the controller has been powered up and running. Reset the spanner icon to off by changing this parameter to 0 and then back to the desired service interval. This process also resets the Run Hours value to 0. To view the current Run Time value refer to the I/O list.
P-19	Switch Resistors	Enables switched resistors to be used for Plant Faults, External Defrosts, Case Clean, Man Trap, Door Switch See : <a href="#">Switched Resistor Values</a>
P-77	Man Stop LLV/Fans	When man trap input is activated the LLV closes and Fans are stopped. Normal operation resumes when the mantrap input is deactivated.
P-98	Lights Case Off	Used to place the controller into Case Off when its lighting timer is in the off state. When the lighting timer is in the on state the controller follows its normal control operation. This feature is disabled if the set point (P-01) is below 6°C. Please note that when the controller is in case off all alarms are inhibited and all outputs are turned off. Therefore care must be taken when enabling this parameter. <ul style="list-style-type: none"> <li>➤ Off – Feature is not used and only the controller lights relay follows the lighting timer status.</li> <li>➤ On – Feature is in use and controller will be in Case Off whenever the lights timer is in the off state.</li> <li>➤ Unused – This selection has no effect and should not be used. Please select from either Off or On. This feature operates in either Local, using controller RTC, or Remote, using Data Manager GP timer channel, lighting applications.</li> </ul>
P-99	Load Shedding	<ul style="list-style-type: none"> <li>➤ Off – Feature is not used</li> <li>➤ Mode 1 – Case goes to Load Shedding Mode 1 (Valve open and fans off)</li> <li>➤ Mode 2 – Case goes to Load Shedding Mode 2 (Valve closed and fans off)</li> </ul> See: <a href="#">Load Shedding</a>
P-20	Alarm Delay	Delay for the over and under-temperature alarms
P-21	UT Alarm	Under temperature alarm set point. This alarm uses the control temperature.
P-22	OT Alarm	Over temperature alarm set point. This alarm uses the air-off temperature.
P-23	Log Probe Type	Allows the user to set the logging probe mode: - <ul style="list-style-type: none"> <li>➤ Off</li> <li>➤ Logging with no alarms</li> <li>➤ Logging with alarms</li> </ul>
P-24	Slug Log Probe	Applies a damping factor. This can be used to make a standard probe have the same temperature response as a logging probe.
P-25	Log Alarm Delay	Delay for the Logging probe over and under-temperature alarms
P-26	Log UT Alarm	Logging probe under temperature alarm set point
P-27	Log OT Alarm	Logging probe over temperature alarm set point
P-28	Monitor OT Alarm	Monitor probe over temperature alarm set point
P-40	Defrost Mode	Allows the user to set the defrost mode: - <ul style="list-style-type: none"> <li>➤ Local (Uses the internal parameters P-41 and P-42)</li> <li>➤ Remote (Requires a defrost schedule in the front end)</li> <li>➤ External (uses a switched resistor in input 1 I or 3 (M)). When this signal is present a defrost is initiated.</li> </ul> Note: - If the external defrost signal is not removed then the controller will defrost according to the "No Defrost" time and a missed defrost alarm will be generated. See P-29 for external



Please ensure all power is switched off before installing or maintaining this product.

Number	Parameter	Description
		defrost signal setup.
P-41	Defrost Start	When defrost mode is set to "Local", this is the start time for the 1 <sup>st</sup> defrost
P-42	Defrosts per Day	When defrost mode is set to "Local", this is the number of defrosts per day equally spaced from the start time.
P-43	No Defrost Time	If the controller misses a defrost command for any reason, a defrost will initiate after this time has elapsed from the last defrost. Normally set to 2 hours over the normal defrost period.
P-44	Def Terminate	The defrost will terminate (defrost control relay off) when the temperature of the defrost termination probe reaches this value. If the "defrost termination" probe is not fitted, defrost termination will occur when: - The "coil in" probe reaches the set point (If fans are selected as "off during defrost") Or The "air off" probe reaches the set point (If fans are selected as "on during defrost"). If the "coil in" probe is not fitted, the "air off" probe will be used.
P-45	Def Min Time	Minimum time that a defrost will use (Defrost can't terminate until this time has elapsed. If termination temperature is reached during this period, the defrost control relay is turned off, but the controller will not continue the defrost cycle until the end of the defrost min period)
P-46	Def Max Time	Time period after defrost minimum that defrosts are allowed to terminate
P-47	Drain Down	A period after defrost max to allow the draining of any surplus water
P-48	Recovery Time	The LLV is switched on at the start of this period to allow the temperature to recover to the normal operating point. This period also inhibits the OT alarm. Note that if the air-off temperature is still above the OT alarm setpoint when this period expires, an immediate OT alarm occurs; there is <b>not</b> a further alarm delay.
P-89	Pump Down Time	Time period before the defrost min period to allow for a pump down
P-86	Fan Delay mode	This parameter allows the fans start after a drain-down period to be delayed, either by time (P-49) or when the temperature point (P-88) is reached. This parameter uses the same probe strategy as the defrost terminate.
P-49	Fan Delay	Time after a drain-down period before the fans start if P-86 is set to time
P-88	Fan Delay Temp	Temperature at which the fans start after a drain-down period when P-86 is set to temperature.
P-50	Fans In Defrost	Allows the user to set the fans on or off in defrost. Note if the fans are set to on in defrost, they will go off for the drain-down period and then follow the P-86 rules.
P-94	Defrost Hold	Turns the defrost hold feature on and off. When switched on, the controller can be held in defrost until a remote command from the front end starts the recovery process.
P-95	Defrost Skip	Allows user to enable/disable defrost skip. This feature allows the controller to skip defrosts. If the current defrost terminates on temperature then the controller will skip the next scheduled defrost providing the previous defrost terminated before the defrost skip time (P-96). Operates only when the controller is set to local defrost scheduling.
P-96	Defrost Skip Time	Time factor used in defrost skip. The previous defrost has to terminate before this value expires to allow the controller to skip a defrost.
P-91	Defrost Type	Electric – Defrost heater will go off during defrost min. period, if defrost termination is achieved, and will stay off. Electric Cin – Defrost heater will go off during defrost min. period if defrost termination is achieved but will then cycle on and off around the termination temperature setpoint until the end of the defrost min. period. Gas (Mobile) – If gas is selected, the compressor is kept running for the duration of the defrost cycle.
P-80	Door alarm delay	Delay after the door open input is activated before the alarm occurs.
P-81	Door Closes Valve	This parameter is used to close the LLV or EEV if the door opens. If the door remains open then the valve will resume normal operation on the expiry of the door alarm delay (P-80).
P-82	Door Stops Fan	This parameter is used to stop the fans if the door opens. If the door remains open then the fans will resume normal operation on the expiry of the door alarm delay (P-80).
P-60	Lights Mode	Allows the user to set the lights mode: - ➤ Always off ➤ Always on ➤ Use a local schedule P-61 to P-74) ➤ Use a remote schedule (Set up in the system front end)
P-61	Sun Lights On	When P-60 is set to Local, Sunday on time
P-62	Sun Lights Off	When P-60 is set to Local, Sunday off time
P-63	Mon Lights On	When P-60 is set to Local, Monday on time
P-64	Mon Lights Off	When P-60 is set to Local, Monday off time
P-65	Tue Lights On	When P-60 is set to Local, Tuesday on time



Please ensure all power is switched off before installing or maintaining this product.

Number	Parameter	Description
P-66	Tue Lights Off	When P-60 is set to Local, Tuesday off time
P-67	Wed Lights On	When P-60 is set to Local, Wednesday on time
P-68	Wed Lights Off	When P-60 is set to Local, Wednesday off time
P-69	Thu Lights On	When P-60 is set to Local, Thursday on time
P-70	Thu Lights Off	When P-60 is set to Local, Thursday off time
P-71	Fri Lights On	When P-60 is set to Local, Friday on time
P-72	Fri Lights Off	When P-60 is set to Local, Friday off time
P-73	Sat Lights On	When P-60 is set to Local, Saturday on time
P-74	Sat Lights Off	When P-60 is set to Local, Saturday off time
P-30	Broadcast ID	ID of Plant Controller being used to broadcast Suction Pressure The Broadcast ID is derived from the Rotary Switch positions set on the Plant controller which is providing the remote suction pressure. <b>Note:</b> No two Plant controllers on a local area network can have the same rotary switches positions set. This will have adverse affects on control.
P-31	Refrigerant	Type of refrigerant used in system. See: <a href="#">Refrigerant Table</a> above
P-110	Ref Weight	Allows for a weighted average between liquid and vapour pressure to be used in the pressure to temperature calculation. See: <a href="#">Ref weight</a>
P-32	Pressure Units	Absolute or Gauge
P-33	Evap Offset	Offset to allow for pressure drop over distance
P-34	Glide	Allows the calculated temperature, derived from the Suction Pressure, to be offset by adding the value at P-34.
P-35	Trans Span	Total range of the transducer
P-36	Trans Offset	Value below zero
dFLt	Restore default values	Restores all of the parameters to their default values

## Load Shedding

Used on CO2 sites for load shedding on CO2 Compressor Faults or CO2 Vessel High Pressure Alarms. Cases can be put into a "CO2 Case Off" mode 1 or mode 2 to reduce the load on the pack or to reduce the CO2 vessel pressure. Mode 1 will open the LLV/EEV and stop the fans, mode 2 will close the LLV/EEV and stop the fans.

See: RDM CO2 load shedding user guide.

## Superheat Options

The superheat for EEV control can be calculated using different means to suit the application. Selectable from parameter P-17 – Evap Select;

- **Local** - Based on the value of the Evaporator and Suction line temperature probe inputs connected directly to the controller.
- **Rem1** - The local suction line temperature probe and a local suction pressure measured by a transducer connected to the refrigeration case island Mercury Hub (PR0018-PHI). The pressure read from the Mercury Hub pressure transducer is converted to a temperature based on the gas type being used by the system. This temperature is transmitted to all controllers connected to the Mercury Hub.  
**Note:** Broadcast ID (P-30) must be set to 0. See section: [Mercury Switch](#) below.
- **Rem1/2/3** - The local Suction line temperature probe and a remote suction pressure value broadcast by a Plant/ Intuitive Pack controller on the same IP network. The pressure received from the Plant/Intuitive Pack controller is converted to a temperature based on the gas type being used by the system. Using an IP Futura or Mercury Switch. **Note:** Broadcast ID (P-30) must be set to the pack's network ID (rotary address). See section: [Plant Pack Controller](#) below.
- **LoBrd** - The local suction line temperature probe and a local suction pressure measured by a transducer connected to the controller's internal daughter card and converted to evaporator temperature. **Note:** Only on Intuitive Mercury variant. See section: [Daughter Card](#) below.

## EEV Control Using Pressure

There are several ways to use the suction pressure to calculate the evaporator in temperature;



Please ensure all power is switched off before installing or maintaining this product.

## Mercury Switch (PR0018-PHI)

(P-17 set to Rem1)

The Mercury Switch can be used for EEV control on an Island by island basis. A suction pressure transducer is connected from the case Island to the 4-20mA input of the Mercury Switch and the pressure read from this transducer is converted to a temperature based on the gas type being used by the system. This temperature is transmitted to each controller connected to the switch and along with the suction temperature probe, local to the controller, the superheat is calculated. Please note that RDM recommended that the evaporator in temperature probe is fitted as the controller will use this to calculate the superheat in the event of a communication loss with the Mercury Switch. P-17 allows for the use of this remote temperature provided by the Mercury Switch. Please see the Mercury Switch user document (PR0018-PHI) for further details.

## Remote pressure Direct from a Plant Pack Controller

(P-17 set to Rem1/ Rem2/ Rem3)

(P-30 set to network ID of Plant Pack)

(P-31 set to refrigerant type)

P-17 is set depending on which input the suction transducer is connected to on the plant controller (i.e. transducer input 1, 2 or 3). The broadcast ID (P-30) should be set to the network ID of Plant Pack Controller (i.e. Rotary Switch Setting). The Refrigerant type (P-31) must be set along with pressure units (P-32) set to Absolute or Gauge.

## Local Daughter Card (Intuitive Mercury)

(P17 set to LoBrd)

(P-31 to P-36) will need to be set accordingly

A suction transducer can be connected directly to the input of the daughter card. The controller will calculate the evaporator temperature from the suction pressure, and along with the suction temperature probe local to the controller, the superheat is calculated. Please note that RDM recommend that the evaporator in temperature probe is fitted as the controller will use this to calculate the superheat in the event of a transducer fault.

## Maximum Operating Pressure (MOP)

If the controller is set to use a local or remote pressure transducer to calculate the suction temperature, then a MOP alarm can be generated (using parameters (P-37/P-38/P-39). When a MOP alarm is generated on the controller, it will either close or reduce the EEV valve opening when a predetermined pressure is reached. This MOP value is configured in the Mercury controller. When the MOP alarm is generated, the controller reduces the maximum valve opening to this percentage. For example if the "EEV Divide Value" parameter is set to 50% and the MOP alarm is generated then the maximum valve opening will be limited to 50%. For M controllers the LLV is closed for the MOP alarm duration.

## Ref Weighting

When using a local pressure transducer to calculate superheat, the Mercury controller can use a weighted average of liquid pressure and vapour pressure to calculate the temperature. For example, when the Ref Weight parameter is set to 50%, then the controller will use a weighted average of 50% liquid pressure and 50% vapour pressure. Any percentage from 1 to 99% will give an appropriate weighted average between the two pressures.



Please ensure all power is switched off before installing or maintaining this product.

## Relay State and functional operation

Relay 1-3 State	Function State	Wired contact
Relay 1 off	Valve / Comp. A on	N/C
Relay 1 on	Valve / Comp. A off	N/C
Relay 1 (SSR) on	EEV Energised	N/C
Relay 1 (SSR) off	EEV De energised	N/C
Relay 2 off	Fans on	N/C
Relay 2 on	Fans off	N/C
Relay 3 off	Lights on	N/C
Relay 3 on	Lights off	N/C
Relay 3 off	Alarm Relay = Alarm	N/C

Relay 4-5 State	Function State	Wired contact
Relay 3 on	Alarm Relay = OK	N/C
Relay 4 off	Suction or Trims off	N/O
Relay 4 on	Suction or Trims on	N/O
Relay 4 off	Alarm Relay = Alarm	N/C
Relay 4 on	Alarm Relay = OK	N/C
Relay 4 off	Compressor B off	N/O
Relay 4 on	Compressor B on	N/O
Relay 5 off	Defrost control off	N/O
Relay 5 on	Defrost control on	N/O

## Relay and screen states during defrost

State	Pump Down	Defrost Min	Defrost Max	Drain Down	Fan Delay	Recovery
<b>Screen:</b>	DEF	DEF	DEF	DEF	DEF	REC
<b>Def LED:</b>	On	On	On	Off	Off	Off
<b>RLY 1 LLV</b>	Closed	Closed	Closed	Closed	Open	Open
<b>RLY 4 Suction Line</b>	Off	On	On	On	Off	Off
<b>RLY 4 Trim on in defrost</b>	On	On	On	On	On	On
<b>RLY 4 Trim off in defrost</b>	Off	Off	Off	Off	Off	On
<b>RLY 5 Defrost Relay</b>	Off	On	On	Off	Off	Off
<b>RLY 3 Lights relay</b>	On	On	On	On	On	On
<b>RLY 2 Fans (On in DF)</b>	On	On	On	On	Off	On
<b>RLY 2 Fans (Off in DF)</b>	On	Off	Off	Off	Off	On

## Defrost Type (P-91)

If P-91 is set to gas, compressor 1 is switched on for the duration of the defrost cycle.

## Defrost Termination

Defrost termination will be when the temperature parameter "def terminate" has been reached on the "defrost termination" probe. If the "defrost termination" probe is not fitted, defrost termination will occur when: -

- The "coil in" probe reaches the set point (If fans are selected as "off during defrost")
- Or The "air off" probe reaches the set point (If fans are selected as "on during defrost")

If the "coil in" probe is not fitted, the "air off" probe will be used. If the "air off" probe is faulty termination will occur when the time-out period has elapsed.

## Fan Delay after Defrost

The fans will come back on when: -

- The fan delay time has elapsed if the "fan delay mode" is set to time
- Or If the fan delay mode is set to "temp", the fans will come on when the defrost termination probe reaches the fan delay set point, or on the time parameter, whichever occurs first.

If the "defrost termination" probe is not fitted, the fans will come on when: -

- The "coil in" probe reaches the control set point (If fans are selected as "off during defrost")
- Or The "air off" probe reaches the control set point (If fans are selected as "on during defrost")

## Network Configuration

The final section to setup is the network address. In all instances, this must be done before the controller is plugged into the site network. The controllers have an auto-initialise function, which will automatically log the device onto the site network. If the wrong address has been entered onto the network, you will have to reset



Please ensure all power is switched off before installing or maintaining this product.

the controller address by setting the address to 00-0, and then re-enter the correct address. (You may have to deregister the wrong address from the home system as well).

When logging a Mercury or Intuitive Mercury with an RS232 interface onto a network you must first connect the controller to a communications module, this is either a 485 Legacy, RDM Wireless Mesh system, IP Futura or Mercury Switch. When using an Intuitive Mercury controller, the controller has to have the correct network card fitted (see "compatible network interfaces"). For connection to a Mercury Switch (Hub) or an external network interface, the standard fitment RS232 network card is utilized.

## RS485 Legacy module / Intuitive Internal RS485 Network card

Connecting an RS485 legacy Module or an Intuitive Internal RS485 network card to the controller will govern which set up screens are made available. Both modules support the "Genus" protocol only.

Display	Option
485t	485 Network Type
485A	485 Address/Name
gAdd	Show underlying network address assigned to controller
rLog	Re-log the controller back onto the network
ClrA	Clear the address/name from the controller
ESC	Exit network menu. <b>N.B.</b> this option <b>must</b> be selected to save any changes made in this menu

The 485t option shows a value representing the network type. The possible values are:

Value	Network Type
1	Genus compatible (all versions)
2	RDM Wireless Mesh System (Wireless Mesh)

The 485A option shows a value representing either the name of the controller in a Genus compatible or Wireless Mesh network.

## Wireless Mesh Communication Module

RDM Wireless Mesh System, please refer to the RDM Wireless Mesh Communication Module user guide, which can be obtained from the RDM website, for information regarding connecting a controller to a Wireless Mesh network.

The value shown in 485A is of the form 05-6. This means the controller would try to log onto a Genus compatible or RDM Wireless Mesh network using the name 'RC05-6'.

The gAdd option displays (in hexadecimal format) the underlying network address assigned to the controller when it was logged onto the network.

The rLog option allows the controller to be logged back onto the network with its current name. The 'rLog' message will flash for confirmation. Press the Enter button to execute the command, Up or Down buttons to cancel.

## Fast Network Address Reset

The ClrA option will clear out the network address and name in the controller. The 'ClrA' message will flash for confirmation. Press the Enter button to execute the command, Up or Down buttons to cancel.

To enter this mode, hold the Enter, Up and Down buttons together for approximately 3 seconds until the message ClrA appears on the display. ClrA is the first option in the menu consisting of the following options:

Display	Option
ClrA	Clear the address/name from the controller
ESC	Exit Setup mode

Pressing the Enter button to select the ClrA option will cause the 'ClrA' message to flash for confirmation, if the network type is set to Genus compatible. Press the Enter button to execute the command, Up or Down buttons to cancel. If the network type is not set to Genus compatible then the ClrA message will not flash and the ESC option can be used to exit the menu.



Please ensure all power is switched off before installing or maintaining this product.

## IP Futura module / Intuitive Internal IP Network card

In an IP system there are two options,

- IP-L
- IP-r

IP-L allows you to fix an IP address into the controller, which you would use when you are connecting the controllers onto a customer's local area network. This would allow the customer to view each controller using Internet Explorer

IP-r allows you to give each controller on the system a unique number. This number is then allocated a dynamic IP address by the system DHCP server (such as the RDM Data Manager or Data Director)

### IP-L

To configure the communication module or network card for IP-L, set all three rotary switches to zero. The module should then be connected to the controller. In the case of an Intuitive Mercury controller where the network card is already fitted, the controller should be powered off, all three rotary switches set to zero and the controller powered on.

nEt. From the function menu you can now select nEt

- Press enter and the display will show "IP-L", press enter
- You can now set the address using the table below

Display	Option
IP-1	IP Address byte 1
IP-2	IP Address byte 2
IP-3	IP Address byte 3
IP-4	IP Address byte 4
nL	Network Mask Length
gt-1	Gateway Address byte 1
gt-2	Gateway Address byte 2
gt-3	Gateway Address byte 3
gt-4	Gateway Address byte 4
ESC	Exit network menu. <b>N.B.</b> this option <b>must</b> be selected to save any changes made in this menu

### IP-r

To configure the communication module for IP-r, set the three rotary switches to give each controller a unique identifier. The module should then be connected to the controller and the network. In the case of an Intuitive Mercury controller where the network card is already fitted, the three rotary switches must be set when the controller is powered off, the controller should then be powered on to connect to the network.

nEt. From the function menu you can now select nEt

- Press enter and the display will show "IP-r", press enter
- You can now view only the address given by the DHCP server

To ease setup, a single network mask length value is used. If the address has been specified with a network mask value in dotted IP format e.g. 255.255.255.0 then the table below gives the conversion:

Mask	Length	Mask	Length	Mask	Length
		255.255.254.0	23	255.254.0.0	15
255.255.255.252	30	255.255.252.0	22	255.252.0.0	14
255.255.255.248	29	255.255.248.0	21	255.248.0.0	13
255.255.255.240	28	255.255.240.0	20	255.240.0.0	12
255.255.255.224	27	255.255.224.0	19	255.224.0.0	11
255.255.255.192	26	255.255.192.0	18	255.192.0.0	10
255.255.255.128	25	255.255.128.0	17	255.128.0.0	09
255.255.255.0	24	255.255.0.0	16	255.0.0.0	08



Please ensure all power is switched off before installing or maintaining this product.

## Mercury Switch

The method of logging on the Mercury 2 will be similar to that of the IP Futura however please refer to the Mercury Switch user guide, which can be obtained from the RDM website, for information regarding connecting a controller to a network.

## Viewing IO

Apart from setting up the controller, you can also view the status of the inputs and outputs and controller states.

From the function menu, select "I/O", press enter. You can now scroll through the IO table as set out below. Inputs and outputs that do not apply to a particular controller type will be greyed out.

## Input / Output Table

Number	IO	Range* °C ( °F )	Step	Units	M Type 1&2	M Type 3&4	M Type 5&6	E Type 3&4	E Type 5&6
I-01	Control Temp.	-42 to 128 (-43.6 to 262)	0.1	Deg	✓	✓	✓	✓	✓
I-02	Display temp.	-42 to 128 (-43.6 to 262)	0.1	Deg	✓	✓	✓	✓	✓
I-03	Air on Probe	-49 to 128 (-56.2 to 262)	0.1	Deg	✓	✓	✓	✓	✓
I-04	Air off Probe	-49 to 128 (-56.2 to 262)	0.1	Deg	✓	✓	✓	✓	✓
I-05	Evaporator Probe	-42 to 128 (-43.6 to 262)	0.1	Deg	✓	✓	✓	✓	✓
I-06	Suction Line Probe	-42 to 128 (-43.6 to 262)	0.1	Deg	✓	✓	✓	✓	✓
I-07	Superheat	-30 to 60 (-54 to 108)	0.1	Deg	✓	✓	✓	✓	✓
I-08	Logging Probe	-49 to 128 (-56.2 to 262)	0.1	Deg	✓	✓	✓	✓	✓
I-09	Defrost Probe	-49 to 128 (-56.2 to 262)	0.1	Deg	✓	✓	✓	✓	✓
I-10	Plant Fault (1)	0 (OK), 1 (Alarm)			✓	✓	✓	✓	✓
I-11	Case Clean	0 (Off), 1 (On)			✓	✓	✓	✓	✓
I-12	Door Sensor	0 (Closed), 1 (Open)					✓		✓
I-13	Person Trapped	0 (OK), 1 (Alarm)					✓		✓
I-14	Plant Fault 2 (Integral)	0 (OK), 1 (Alarm)			✓				
	External Defrost (EEV)	0 (Off), 1 (On)			✓			✓	✓
I-15	Monitor Probe	-49 to 128 (-56.2 to 262)	0.1	Deg		✓	✓	✓	✓
I-16	Remote Evap Temp	-49 to 128 (-56.2 to 262)	0.1	Deg					
I-17	MOP	0 (Off), 1 (On)				✓	✓	✓	✓
I-18	External Defrost (Mechanical Valve)	0 (Off), 1 (On)			✓	✓	✓		
	Hub Trim Level (EEV)	0 to 100	1.0	%				✓	
I-19	Divide Input	0 to 100	1.0	%				✓	✓
I-20	Remote Pressure	-3.4 to 180.0	0.1	Bar				✓	✓
I-21	Local Pressure	-3.4 to 180.0	0.1	Bar				✓	✓
I-22	Local Calc temp	-49 to 128 (-56.2 to 262)	0.1	Deg				✓	✓
I-25	Load Shed	0 (Off), 1 (On)				✓	✓	✓	✓
O-01	Liquid Line Valve	0 (Off), 1 (On)				✓			
O-02	Suction Line Valve	0 (Off), 1 (On)					✓		✓
O-03	Compressor A	0 (Off), 1 (On)			✓				
O-04	Compressor B	0 (Off), 1 (On)			✓				
O-05	Defrost Control	0 (Off), 1 (On)			✓	✓	✓	✓	✓
O-06	Lights	0 (Off), 1 (On)			✓	✓	✓	✓	✓
O-07	Case Fans	0 (Off), 1 (On)			✓	✓	✓	✓	✓
O-09	EEV Opening	0 to 100	0.1	%				✓	✓
O-10	Last Def. Time	00:00 to 23:59		hh:mm	✓	✓	✓	✓	✓
O-11	Last Def. Length	00:00 to 03:00		hh:mm	✓	✓	✓	✓	✓
O-12	Last Def. Ctrl Temp.	-42 to 128 (-43.6 to 262)	0.1	Deg	✓	✓	✓	✓	✓
O-13	Last Def. Type	0 (None), 1 (Internal), 2 (External), 3 (Network), 4 (Display), 5			✓	✓	✓	✓	✓



Please ensure all power is switched off before installing or maintaining this product.

Number	IO	Range* °C ( °F )	Step	Units	M Type 1&2	M Type 3&4	M Type 5&6	E Type 3&4	E Type 5&6
		(Timed) 6 (Forced), 7 (Skipped)							
O-14	Suction Line Valve/Trim Heaters	0 (Open/Off), 1 (Closed/On)				✓		✓	
O-15	Alarm Relay (Relay3)	0 (Unused), 1 (OK), 2 (Alarm)				✓	✓	✓	✓
O-16	Alarm Relay (Relay4)	0 (Unused), 1 (OK), 2 (Alarm)			✓	✓	✓	✓	✓
O-17	Remote Relay (Relay 4)	0 (Off), 1 (On)			✓	✓	✓	✓	✓
O-18	Run Time	0 – 128 K Hours	1		✓	✓	✓	✓	✓
O-20	Door Open Time	00:00 to 23:59		hh:mm					✓
O-21	Door Open Length	00:00 to 03:00		hh:mm					✓
O-30	Set Point Offset	-49 to 128 (-56.2 to 262)	0.1	Deg.	✓	✓	✓	✓	✓
O-31	Trim Off Period	00:00 to 05:00	00:01	mm:ss		✓		✓	
S-01	Control State	0 (Stabilise),1 (Normal), 2 (Defrost Min), 3 (Defrost Max), 4 (Drain Down), 5 (Fan Delay), 6 (Recovery), 7 (OT Alarm), 8 (UT Alarm), 9 (Fans Only), 10 (Lights Only), 11 (Case Off),12 (Pump Down), 13 (Defrost Hold), 14 (Load Shed)			✓	✓	✓	✓	✓
S-02	Valve State	0 (Off), 1 (Start), 2 (Run), 3 (Problem), 4 (Fail), 5 (Shed)							

\* Range is dependent on probe type

## Maximum and Minimum Control Temperature

Type M only (Not supported in type E).

To view the maximum or minimum Control Temperature the controller has reached since last power off/on press and hold the Up and Down Buttons together for 3 seconds. The display will show "diSP", press the Up Button to view the maximum Control Temperature the controller has reached or press the Down Button to view the minimum Control Temperature the controller has reached.

Display will revert back to normal operation if the Enter Button is pressed or after 1 minute of no button presses. The top bar of the left hand segment will be lit when the maximum temperature is being displayed. The bottom bar of the left hand segment will be lit when the minimum temperature is being displayed. Resetting the controller will clear out these values.



Please ensure all power is switched off before installing or maintaining this product.

## Messages

The following alarms and messages can appear on the Mercury display.

Display Message	System status	Display Message	System status
Ft	Control Fault	LitS ONLY	Controller in Lights Only
Prb1	Probe 1 Fault	CASE OFF	Controller in Case Off
Prb2	Probe 2 Fault	Ot	Over Temperature Alarm
Prb3	Probe 3 Fault	Ut	Under Temperature Alarm
Prb4	Probe 4 Fault	door	Door Open Alarm
Prb5	Probe 5 Fault	TrAP	Person Trapped Alarm
Prb6	Probe 6 Fault	PLnt	Plant Fault
rEC	Control State in Recovery	LgOt	Log Probe Over Temperature
dEF	Control Sate in Defrost	LgUt	Log Probe Under Temperature
AL	Control State in Alarm	FanS ONLY	Controller in Fans Only

## Network Alarms

The table below shows the text and associated type number that is sent to the system "front end". The type number is normally used to provide different alarm actions.

Alarm text	Type # (index)	Alarm text	Type # (index)
Missed defrost	15	Person Trapped	1
Plant Fault 1	3	Plant Fault 2	3
Case over temperature	4	Monitor Probe OT	12
Case under temperature	5	Case Off	29
Probe 1,2,3,4,5 or 6 Faulty	6	Remote evap temperature	6
Door Left Open	2	IO Brd evap temperature	6
Product over temperature	8	Load Shedding	7
Product under temperature	9	Lights Only	29
MOP Alarm	3		

## Modifying controller states

During normal operation you can change the following states from the function menu

### Fans Only "FanS"

Selecting the Fans Only option will put the controller into the Fans Only state if the current state is not Fans Only. If the current state is Fans Only then the controller will change to the Normal state. Selecting this option will exit the setup menu automatically. The display will show "FanS OnLy"

If a remote display with key switch is being used, this function can be invoked by turning the key switch to the fans only position (90 degrees clockwise) with parameter P85 set to "fans".

### Case Off "CASE"

Selecting the Case Off option will put the controller into the Case Off state if the current state is not Case Off. If the current state is Case Off then the controller will change to the Normal state. Selecting this option will exit the setup menu automatically. The display will show "CASE OFF". An alarm is generated, fixed delay of 1 minute, when the controller is placed into the Case Off state.

If a remote display with key switch is being used, this function can be invoked by turning the key switch to the case-off position. (Clockwise 90 degrees) with parameter P85 set to "case".



Please ensure all power is switched off before installing or maintaining this product.

## Lights Only “Ligt”

Selecting the Lights Only option will put the controller into the Lights Only state if the current state is not Lights Only. If the current state is Lights Only then the controller will change to the Normal state. Selecting this option will exit the setup menu automatically. The display will show “LitS OnLy”. An alarm is generated, fixed delay of 1 minute, when the controller is placed into the Lights Only state.

Note. When lights are being used in “Remote” mode with a timing channel: -

If the controller goes offline, the lights are turned ON after a delay of 5 minutes. The lights will stay on until the controller comes back on-line where they will revert to the state of the timing channel being used.

## Probe Offset

This feature allows each probe value to be modified by an “offset”. Offset values are from -10°C (-18°F) to +10°C (+18°F) and on a channel basis. Example C1 = Probe 1.

## Remote Commands

The following commands can be used by a Data Builder program: -

Command	Value to send	Description	Conditions
Defrost Command	1	Initiates a defrost cycle	Defrost mode: remote
Defrost Command	3	Terminates the defrost	Defrost mode: remote Defrost hold: On Defrost min state complete
Trim Command	0 to 100%	Sets the trim level to this value (Trim period is 5 minutes)	Relay 4 mode: Trim Heater
Setpoint Command	+/-18	Is added to or subtracted from the setpoint	
Case Off Command	5 8 0	Sets the controller to Case Off Sets the controller to Lights Only Restores the controller from Case Off / Lights Only to Normal	
Haccp Command	0 1 2	HACCP LED OFF HACCP LED On HACCP LED Flashes	
Button Command	0 1 2	Buttons backlights Off Buttons backlights On Buttons Backlights Flash	
EEV Command	2 1	Shuts the valve off Restores the valve to normal operation	
Divider Command	0 to 100%	Sets the maximum valve opening to this percentage.	

**Note:** When using the Case Off Command, the controller will generate an alarm after one minute to let the user know that the controller is in this state.

Use an “Analogue Out” block configured to the controller name and in the value field type in the command you require. Use a “Setting block” as the input to the “Analogue Out” block to send the Value.

See Example on the right, which sets the Trim Heater on BY10-1 at 40%

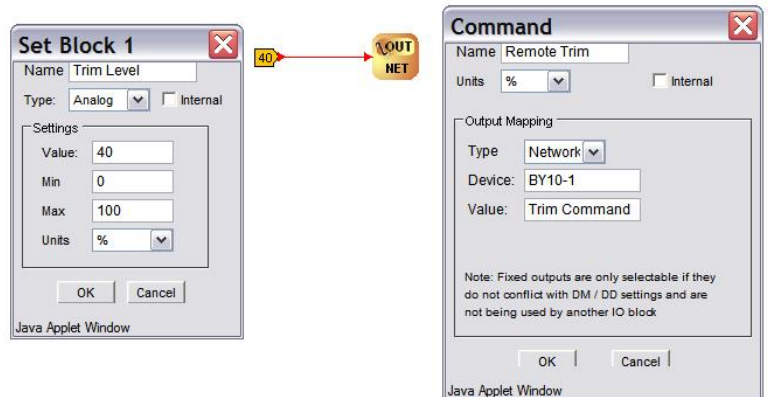

Please ensure all power is switched off before installing or maintaining this product.

## Specification

	<b>Mercury Mk2 Controller</b> PR0710, PR0711, PR0720 & PR0721	<b>Intuitive Mercury controller</b> PR0750, PR0751, PR0760, PR0761
<b>Power Requirements</b>		
<b>Supply Voltage Range</b>	100 – 240 Vac $\pm$ 10%	100 – 240 Vac $\pm$ 10%
<b>Supply Frequency</b>	50 – 60 Hz	50 – 60 Hz
<b>Maximum supply current</b>	5.2 Amps (when relay 5 is fully loaded)	2 Amps
<b>Typical supply current</b>	<1 Amp	<1 Amp
<b>General</b>		
<b>Operating temperature range</b>	-10°C to 60°C (14°F to 140°F)	-10°C to 60°C (14°F to 140°F)
<b>Storage temperature range</b>	-20°C to 65°C (-4°F to 149°F)	-20°C to 65°C (-4°F to 149°F)
<b>Environmental</b>	Indoor use at altitudes up to 2000m, pollution degree 1, installation category II. Voltage fluctuations not to exceed $\pm$ 10% of nominal voltage.	Indoor use at altitudes up to 2000m, pollution degree 1, installation category II. Voltage fluctuations not to exceed $\pm$ 10% of nominal voltage.
<b>Size</b>	78mm (W) x 36mm (H) x 110mm (D)	157mm (W) x 67mm (H) x 120 (D)
<b>Approx Weight</b>	170 grams	500 grams
<b>Safety</b>	EN61010	EN61010
<b>EMC</b>	EN61326; 2013 +Amdt. A1; 1998	EN61326; 2013 +Amdt. A1; 1998
<b>Ventilation</b>	There is no requirement for forced cooling ventilation	There is no requirement for forced cooling ventilation
<b>Class 2 Insulation</b>	<b>No</b> protective Earth is required and <b>none</b> should be fitted	<b>No</b> protective Earth is required and <b>none</b> should be fitted
<b>Supply Fuse</b>	The host equipment must provide a suitable external over-current protection device such as: - Fuse: 6.3A 240 Vac Antisurge (T) HRC conforming to IEC 60127	Built in fuse holder, fuse 2A 240Vac Antisurge (T) HRC conforming to IEC60127, 32 x 6.3mm
<b>Or MCB</b>	6A, 240 VAC Type C conforming to BS EN 60898	2A, 240 VAC Type C conforming to BS EN 60898 (Note: controller has integral 2A fuse)
<b>Relay Fuse</b>	Not Fitted	10A 240Vac Antisurge (T) HRC conforming to IEC60127, 32 x 6.3mm
<b>Relay Specification</b>		
<b>Relays 1-4 Mechanical Type (M) - Exclusive common</b>		
<b>Max current</b>	6A Resistive (Cos $\phi$ = 1) 2A Inductive ( Cos $\phi$ = 0.4)	.10A Resistive (Cos $\phi$ = 1) 3A Inductive ( Cos $\phi$ = 0.4)
<b>Max voltage</b>	250Vac, 30V dc	250Vac. 30V dc
<b>Relay Fuse</b>	N/A	10A 240Vac Antisurge (T) HRC conforming to IEC60127, 32 x 6.3mm
<b>Relay 1 Solid State Type (E) - Exclusive common</b>		
<b>Max current</b>	1.5A	1.5A
<b>Max voltage</b>	280Vac (ac only, will not switch dc)	280Vac (ac only, will not switch dc)
	<b>Relay 5 Mechanical Type (M) Common connected to supply live</b>	<b>Relay 5 Mechanical Type (M) Exclusive common</b>
<b>Max current</b>	3A (non inductive), COS $\phi$ =0.4 2A (inductive load) 200,000 operations	10A Resistive (Cos $\phi$ = 1) 3A Inductive ( Cos $\phi$ = 0.4)
<b>Max voltage</b>	250Vac (Internal supply)	250Vac. 30V dc (external supply)
	For compliance with the LVD, relays 3, 4 and 5 commons must be at the same potential as the supply voltage	All relays are independent and can operate at different potentials to the supply voltage.



**Warning: Relay 5 output has hazardous voltages (Supply input voltage potential)**

**This does not apply to the Intuitive Mercury controller**



Please ensure all power is switched off before installing or maintaining this product.

## Inputs

Input resistance: 3.01K Ohms (for PTC or NTC type probes)  
 Input type: Selectable. See: [Units](#)  
 Comms: RS232 with flow control

## Switched Resistor Example Wiring

Example of resistor fitted on a probe. Connect to remote switch or relay

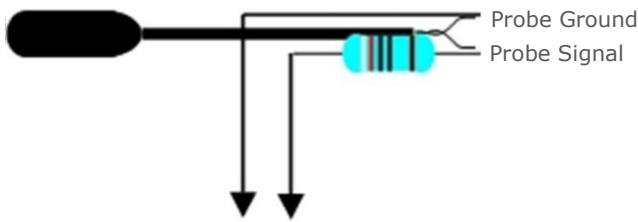

## Installation

### Panel Cut-out and Clearances

#### Mercury Mk2 (Flush mount controller)

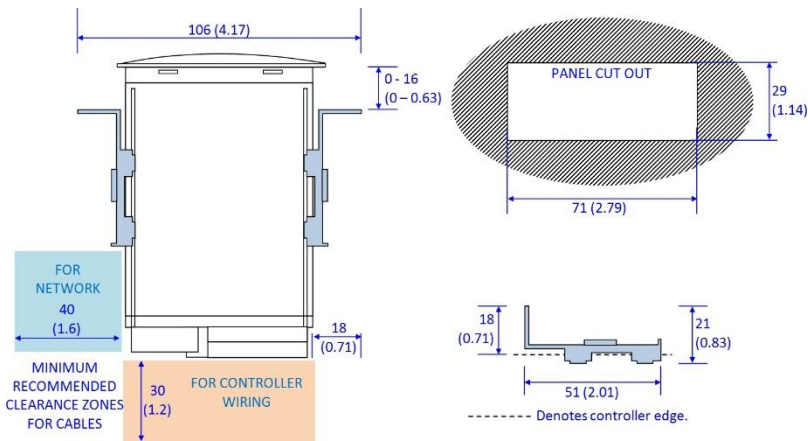

### Fixing

The controller is fixed by sliding the 2 plastic retaining clips up to rear of the panel. These clips have a ratchet action and can be removed by holding in the clip sides and sliding back.

There is no requirement for forced cooling ventilation



Please ensure all power is switched off before installing or maintaining this product.

## Dimensions

### Mercury Mk2

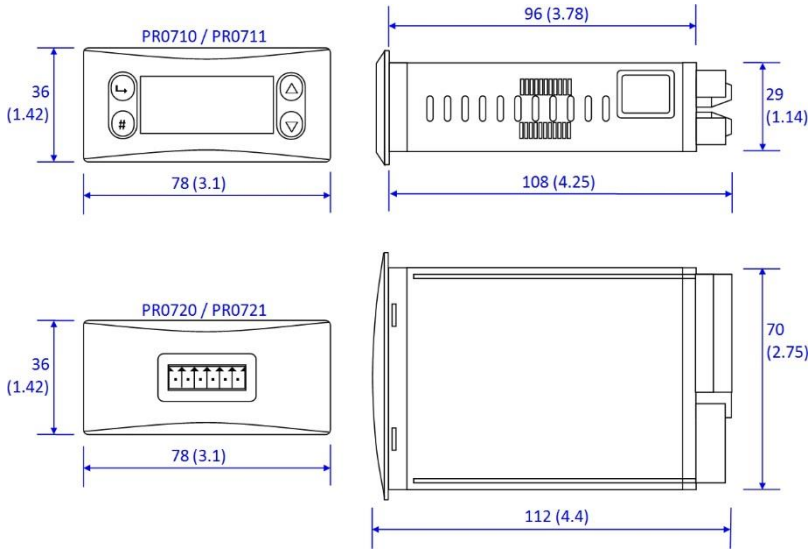

## Dimensions

### Intuitive Mercury controller

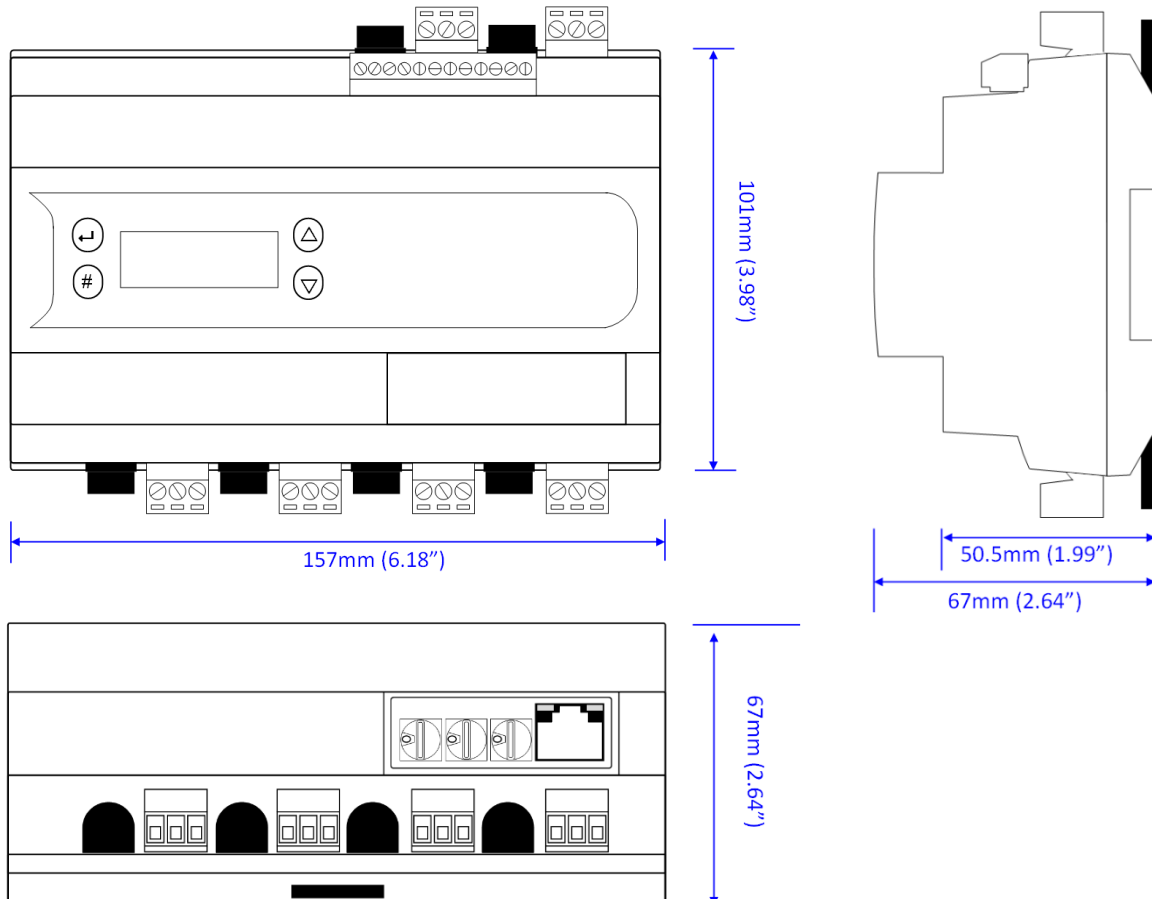

Please ensure all power is switched off before installing or maintaining this product.

## Intuitive Mercury Mounting Instructions

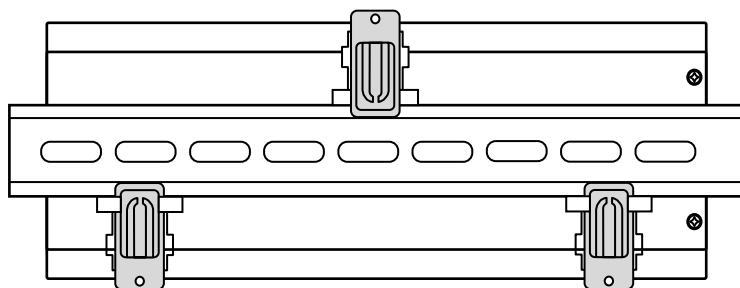

Three clips fix the Intuitive Mercury securely to DIN rail. Pull each clip until it “clicks” to remove the controller. Each clip has a mounting hole to provide an alternative fixing mechanism to DIN mounting.

## Cleaning

Do not wet the controller when cleaning. Clean the front by wiping with slightly dampened lint free cloth.

## Disclaimer

The specifications of the product detailed in this document may change without notice. RDM Ltd shall not be liable for errors or omissions, for incidental or consequential damages, directly or indirectly, in connection with the furnishing, performance or misuse of this product or document.



Please ensure all power is switched off before installing or maintaining this product.

# Appendix 1 Defrost Cycles

## Fans On in Defrost

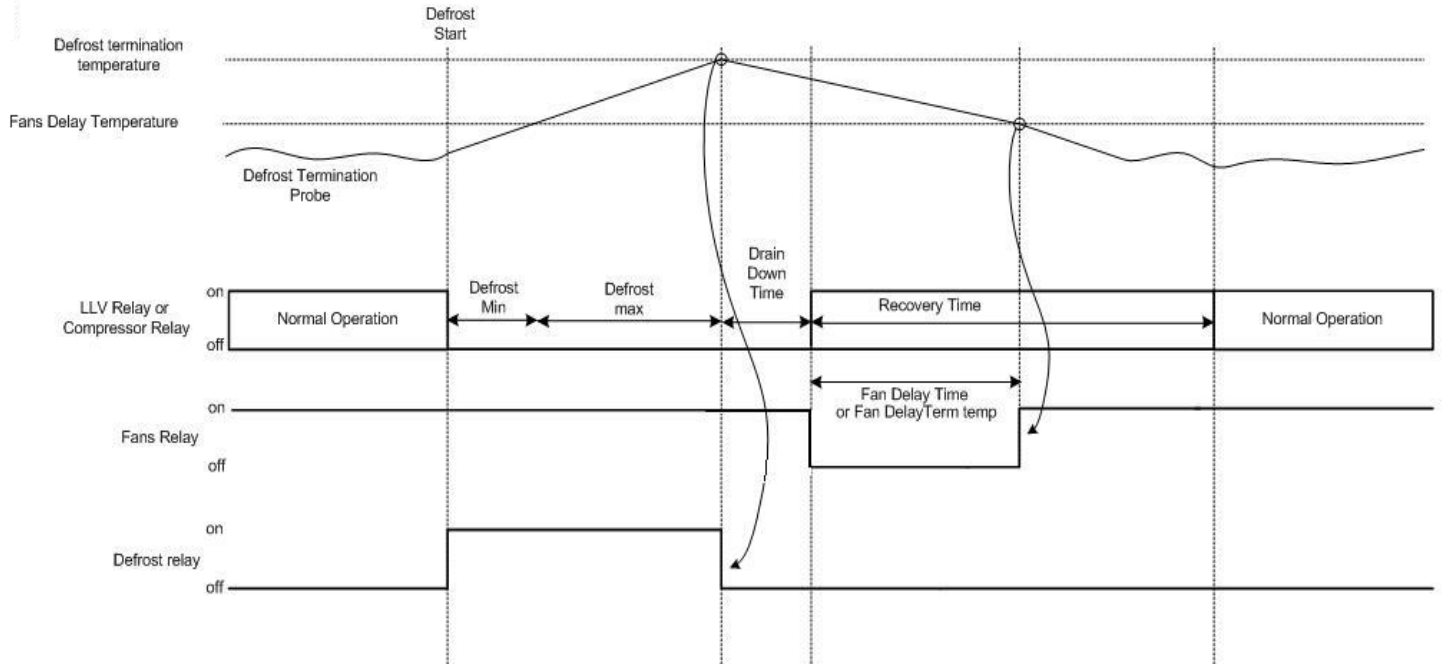

## Fans Off in Defrost

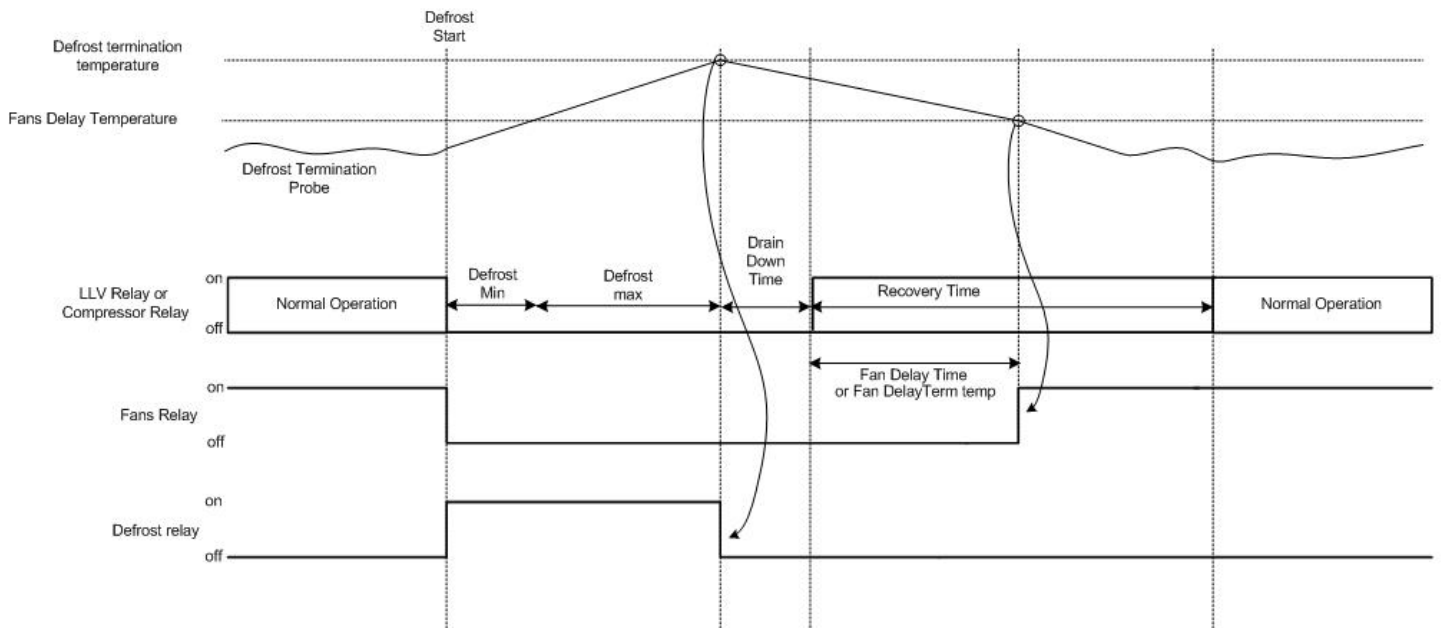

Please ensure all power is switched off before installing or maintaining this product.

## Appendix 2 Trim Heater Control via Mercury/Intuitive Range

Energy savings via the RDM's range of case controllers can be achieved in a number of ways. One of which is pulsing the trim heater relay off for a given period of time. One way to pulse the trim heater is by configuring P-14. For greater energy savings the Data Manager energy feature trim control or the Mercury Switch trim control feature can be used. These two options pulse the trim relay dependent on the actual shop floor humidity levels. Thus if the shop floor humidity is relatively low the trim heaters can be pulsed off for longer durations. Please see the relevant user guides for further details.

RDM recommend that the Trim Heater Pulse Module (PR0723) is used in all instances of trim control. This module is fitted in between the trim heater of the case and the relay output of the Controller which is pulsing the heater. The trim heater module output provides a smoother power distribution, compared to using the relay output directly, as it switches at the zero voltage crossover point. Switching the trim heater on and off via a normal relay, without using the RDM trim heater pulse module, may damage the trim heater and reduce the operational life of the heater. Therefore RDM recommend the use of this module in every trim heater control application. Please see the Trim Heater Pulse Module user guide for further details.

## Revision History

Revision	Date	Changes
1.0A	28/09/2011	Introduction of Intuitive range
	15/03/2012	SSR Spec, AC voltage only, can't switch DC, statement clarified.
1.1	01/08/2012	Load Shedding added, daughter cards added for pressure input, pressure broadcasting from Plant Pack
1.1A	13/08/2012	Parameter description amended
2.0	18/10/2013	New Processor, Cycle defrost heater option.
2.0a	22/01/2014	PT1000 range increased.
2.2	12/03/2014	Software update, Suction line closed during pump down and fans running. (E2.5)
2.2a	20/03/2014	P-34 Description updated.
2.2b	25/03/2014	P-56 Description updated
2.2c	04/08/2014	Description for Superheat options updated
2.2d	20/10/2014	Description for valve problem state updated to include control problem state. (P-52)
2.2e	20/11/2014	Modification to valve control after defrost. (E2.6)
2.2f	26/02/2015	Load shedding mode 2 description added.
2.2g	06/08/2015	P-18 Tick boxes amended on parameters list.
2.2h	16/10/2015	NF – Non Fused version added to ordering information
2.2i	18/01/2016	P-83 Description updated to show the correct order.
2.3	21/01/2016	Remote Lights Only command added. R449A and R513A gassed added.
2.3a	01/03/2016	Evap offset range increased.
2.4	28/04/2016	'dtyP' menu option added, this allows you to use a Mercury or Coldroom display.
2.4a	12/05/2016	Amending layout within document
2.5	03/06/2016	Div Size (P-58) added. Enables use of EEV Divide value (P-57)
2.5a	28/06/2016	Superheat Options description updated
2.5b	28/06/2016	Note added for Superheat control
2.5c	21/12/2016	Remote defrost termination from Data Manager added.
2.5d	17/05/2017	Operating temperature amended.
2.6	05/06/2017	Amendment to MOP functionality added. Refrigerant gas table updated. Ref weight parameter added. New documentation format.
2.6a	05/07/2017	Relay table amended to show SSR output as well as mechanical relay.
2.6b	08/06/2017	Parameter table amended
2.6c	06/07/2018	Description of P-57 and P-58 Div value and size updated.
2.6d	20/08/2018	Range of P-34 (Glide) updated.
2.6e	17/04/2019	MOP alarm function during defrosts altered.



Please ensure all power is switched off before installing or maintaining this product.

## Group Offices

### RDM Group Head Office

80 Johnstone Avenue  
Hillington Industrial Estate  
Glasgow  
G52 4NZ  
United Kingdom

+44 (0)141 810 2828  
[support@resourcedm.com](mailto:support@resourcedm.com)

### RDM Inc

100 North Sixth Street  
Suite 630B  
Minneapolis, MN  
55403  
United States

+1 612 354 3923  
[usasupport@resourcedm.com](mailto:usasupport@resourcedm.com)

### RDM Asia

Sky Park at One City  
Jalan USJ 25/1  
47650 Subang Jaya  
Selangor  
Malaysia

+60 3 5022 3188  
[info@rdmasia.com.my](mailto:info@rdmasia.com.my)



Visit [www.resourcedm.com/support](http://www.resourcedm.com/support) for more information on RDM solutions, additional product documentation and software downloads.

While every effort is made to ensure the information given within this document is accurate, Resource Data Management Ltd shall not be liable for errors or omissions, for incidental or consequential damages, directly or indirectly, in connection with the furnishing, performance or misuse of this product or document. All specifications are subject to change without notice.

See [www.resourcedm.com](http://www.resourcedm.com) for terms and conditions of sales.

Copyright © Resource Data Management