



**Mercury
PR0710-AC
PR0720-AC**



**Intuitive
PR0750-AC
PR0760-AC**

Mercury 2 & Intuitive Mercury Air Conditioning Controller Installation & User Guide



Resource Data Management Ltd
 80 Johnstone Avenue, Hillington Industrial Estate,
 Glasgow, Scotland G52 4NZ UK
 ☎ +44(0)141 810 2828 Switchboard
 ✉ support@resourcedm.com Technical Support
 ✉ sales@resourcedm.com Sales Enquiries



Table of Contents

THE MERCURY & INTUITIVE AIR CONDITIONING CONTROLLER 3

Networks..... 3

Front Panel Features 3

 LED's: - 3

 Keys 4

 Main Display 4

Connections 4

Input/Output Allocation Tables 5

 Input / Output allocation tables. 5

Setting up the controller 5

 Setup Mode 5

 Setup through front buttons 5

 Setup Function Menu 6

Recommended set-up method 6

 rtc. Real time clock (This will automatically synchronise on network systems) 6

 PArA. Set/view parameters (This can be achieved at the network front end) 6

 Unit. Set/view temperature unit and Probe type 6

 Display 7

Parameter Tables:..... 7

 Parameter Description 8

Relay State and functional operation 9

Control Strategy..... 9

Condenser Low Temperature (Frost Protection) 9

Flow Diagram 10

Network Configuration 11

 485 Legacy module 11

 Wireless Mesh Communication Module 11

 Fast Network Address Reset 11

 IP Futura module 12

Viewing 13

 Input/Output table 13

Alarm Messages 13

Network Alarms 14

Remote Commands:..... 14

 Power requirements 15

 General 15

 Relay Specification 15

Specification 15

 Inputs 16

Installation..... 16

Dimensions 16

 Fixing 16

Dimensions 17

 Intuitive Mercury Mounting Instructions 17

 Cleaning 17

Disclaimer..... 17

REVISION HISTORY..... 18



Ensure that all power is switched off before installing or maintaining this product

The Mercury & Intuitive Air Conditioning Controller From Resource Data Management

This controller is used to control a simple air conditioning system comprising an evaporator, evaporator pump, condenser, condenser pump and a compressor. It will switch the evaporator pump, condenser pump and compressor based on the values of its evaporator water in, evaporator water out and condenser water out temperature probe inputs. The controller has a built in 7 day time clock to enable timed operation of the air conditioning system.

The controller supports PT1000, NTC2K, 470R, 700R, 3K, 5K, 6K, NTC2K25, NTC10K or NTC10K(2) Temperature probes (Note: probe types cannot be mixed)

Networks

The controllers are capable of connecting to either a TCP/IP local area network or a RS485 network or controlling in standalone mode with no network output.

To connect to a network you must add the correct communications module.

- 485 Legacy module (Part No PR0026)
- IP Futura module (Part No PR0016)
- Mercury Switch (Part No PR0018 or PR0018-PHI)
- Wireless Mesh Radio Interface (Part No. PR0730)

Connecting to any of these communication modules will automatically be detected on power up and will affect the set up screens available to you.

Front Panel Features

LED's: -

**Compressor
(Relay 2)**



On when compressor is running.
Flashing when start delay timer is running.

**Evaporator Pump
(Relay 1)**



Timer On



**Condenser Pump
(Relay 3)**



On-Line



- Off No network attached
- Flashing Attempting to Log on to network
- Steady On-line

Service



(See Parameter 26 for setup)

Alarm



HACCP

HACCP



Ensure that all power is switched off before installing or maintaining this product

Keys

Enter



Up



Down



Reset



Note: Function keys illuminate when pressed, illumination is turned off 20 seconds after the key is used.

Main Display



4 character blue LED display, used to display temperature and status messages.

Connections

Input and Output connections are made to the back of the controller, the RS232 communication port is on the side. The diagram below shows the connection detail. Inputs and outputs are assigned according to the chosen configuration. See Input/Output tables for further details on connections.

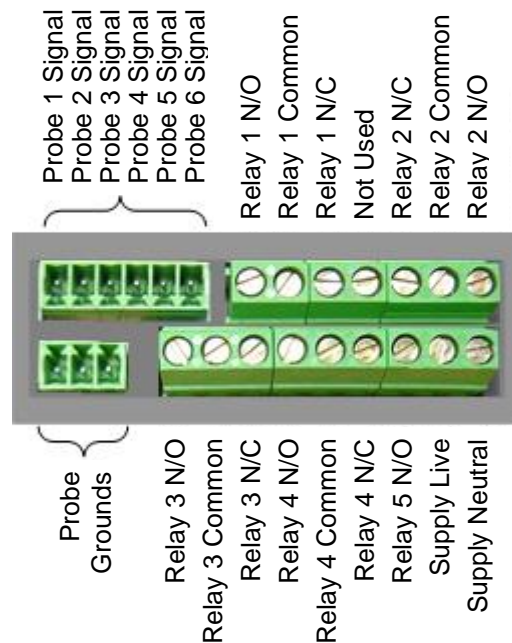

Do not connect an earth.



Ensure that all power is switched off before installing or maintaining this product

Input/Output Allocation Tables

The following tables indicate; on a controller type basis, the functions of the inputs and outputs. Also shown are the digital inputs that are derived by switching the input to the ground, these can be a N/O or N/C contact (see parameters 20, 21 & 22)

Input / Output allocation tables.

		Alarm Action
Input 1	Evaporator In Water Temperature	Yes
Input 2	Evaporator Out Water Temperature	Yes
Input 3	Condenser Out Water Temperature	Yes
Input 4	Evaporator Pressure/Pump Fault	Yes
Input 5	Compressor Thermal Overload	Yes
Input 6	HP/LP Fault	Yes
Relay 1	Evaporator Pump	N/A
Relay 2	Compressor	N/A
Relay 3	Condenser Pump	N/A

Setting up the controller

Access to the controller can be achieved several ways

- Through the front mounted buttons
- Direct access by PC into the rear comms. port. This requires a software package available on the RDM website
- Through legacy front end panels on 485 networks
- Through the RDM Data Manager.
- Across an IP network. (Current controller IP address required)

Setup Mode

Setup through front buttons



To enter setup mode, hold the Enter and Down buttons together for approximately 3 seconds until the message "Ent" appears on the display. Now press the Enter button again to enter the function menu. IO will be displayed. Scroll up or down to go through the list.



Ensure that all power is switched off before installing or maintaining this product

Setup Function Menu

Display	Option	Explained in Paragraph
IO	View Inputs / Outputs and States	Input / output table
PArA	Set/View Parameters	Set view parameters
Unit	Probe type and Celsius/Fahrenheit option	Set View Unit
diSP	Display whole units or decimal	Display
tyPE	Set/View Controller Type	See note below*
rtc	Set/view Clock (rtc = Real Time Clock)	Real Time Clock
nEt	Set/view network configuration	Network Configuration
SoFt	View software version	
OFSt	Probe Offset	Probe Offset
ESC	Exit Setup mode	

* Note, this controller has no variants so there is only one controller type, this is set to 1.

Recommended set-up method

If you are not connecting to a network and want to set up the controller through the buttons we recommend you use the following order from the function menu.

rtc. Real time clock (This will automatically synchronise on network systems)

- Use the up or down buttons to scroll through the display until the display reads “rtc”
- Press enter. The display will show “t-1”. press enter again
- Scroll hours up or down (0 – 23) press enter
- Use up button to select “t-2”, press enter
- Scroll minutes up or down (0 – 59) press enter
- Repeat for t-3 (seconds 0 – 59)
- Repeat for t -4 (Days up to 31)
- Repeat for t -5 (months up to 12)
- Repeat for t -6 (Year up to 99)
- Use up button to display “ESC”, press enter to display “rtc”

Time clock is now set

PArA. Set/view parameters (This can be achieved at the network front end)

- From the function menu scroll to select PArA
- Pressing Enter while PArA is displayed will enter the parameter menu. The first parameter option will be displayed as P-01. Pressing the Up or Down button will present the other parameter options P-02, P-03 etc. See the parameter list below to find what parameter number corresponds to which actual parameter. Pressing the Enter button will show the current value of the selected parameter. Press Up or Down to modify the value and press Enter again to save the value. The parameter list number will be displayed again. Two other options are present in the parameter menu – dFLt and ESC. Selecting ESC will exit setup mode. Selecting dFLt will reset all parameters back to the default values for the current type of controller.

Unit. Set/view temperature unit and Probe type

From the function menu scroll to select Unit

Press enter and the value will be displayed: -

Probe Types

0 for PT1000 Celsius	9 for 3K Fahrenheit	18 for NTC10K(2) Celsius (USA NTC10K)
1 for PT1000 Fahrenheit	10 for NTC2K25 Celsius	19 for NTC10K(2) Fahrenheit (USA NTC10K)
2 for NTC2K Celsius	11 for NTC2K25 Fahrenheit	
3 for NTC2K Fahrenheit	12 for 5K Celsius	
4 for 470R Celsius	13 for 5K Fahrenheit	
5 for 470R Fahrenheit	14 for 6K Celsius	
6 for 700R Celsius	15 for 6K Fahrenheit	
7 for 700R Fahrenheit	16 for NTC10K Celsius	
8 for 3K Celsius	17 for NTC10K Fahrenheit	

Use the up or down keys to select the units and press enter.

This function is now complete



Ensure that all power is switched off before installing or maintaining this product

Display

From the function menu scroll to and select diSP.

Press enter and one of the following values will be shown: -

0 controller display will show the whole number and tenths value of a temperature reading.

1 controller display will show temperatures as a whole number.

Display defaults to 0.

Parameter Tables:

Number	Parameter	Range	Step	Units	Default
P-01	Cut-in Temp	-42 to 30 °C (-45 to 86 °F)	0.1	Deg	12 °C (54 °F)
P-02	Diff	0 to 10 °C (0 to 18 °F)	0.1	Deg	3 °C (5.4 °F)
P-03	Control Weight	0 to 100	1	%	50
P-04	Display Weight	0 to 100	1	%	50
P-05	Starts per Hour	0-10 (Set to 0 if not required)	1		6
P-06	Pump Reset Time	00:00 to 99:00	1 min.	mm:ss	30:00
P-07	Pump Flow Detect	00:00 to 15:00	1 sec.	mm:ss	00:05
P-08	Comp. Reset Time	00:00 to 99:00	1 min.	mm:ss	30:00
P-09	Comp. OT Trip Time	00:00 to 99:00	1 min.	mm:ss	20:00
P-10	Comp. UT Trip Time	00:00 to 00:15	1 sec.	mm:ss	00:10
P-11	Compressor Retries	0 to 10	1		2
P-13	Condenser Run On	00:00 to 15:00	1 sec.	mm:ss	00:01
P-14	Condenser Pre-Run	00:00 to 15:00	1 min.	mm:ss	01:00
P-20	Fault Input 1 Polarity	0 to 1 (1=N/C 0=N/O)	1		1
P-21	Fault Input 2 Polarity	0 to 1 (1=N/C 0=N/O)	1		1
P-22	Fault Input 3 Polarity	0 to 1 (1=N/C 0=N/O)	1		1
P-26	Service Time	0 to 128	1 K Hr.	K Hour	1
P-30	Evap. In OT/UT Alarm Delay	00:00 to 99:00	1 min.	mm:ss	20:00
P-31	Evap. In UT Alarm	-49.0 to 120 °C (-56.2 to 248 °F)	0.1	Deg	3.0 °C (5.4 °F)
P-32	Evap. In OT Alarm	-49.0 to 120 °C (-56.2 to 248 °F)	0.1	Deg	30 °C (86 °F)
P-33	Evap. Out OT/UT Alarm Delay	00:00 to 99:00	1 min.	mm:ss	20:00
P-34	Evap. Out UT Alarm	-49.0 to 120 °C (-56.2 to 248 °F)	0.1	Deg	3.0 (5.4 °F)
P-35	Evap. Out OT Alarm	-49.0 to 120 °C (-56.2 to 248 °F)	0.1	Deg	30 °C (86 °F)
P-36	Cond. OT/UT Alarm Delay	00:00 to 99:00	1 min.	mm:ss	20:00
P-37	Cond. UT Alarm	-49.0 to 120 °C (-56.2 to 248 °F)	0.1	Deg	3.0 °C (5.4 °F)
P-38	Cond. OT Alarm	-49.0 to 120 °C (-56.2 to 248 °F)	0.1	Deg	30 °C (86 °F)
P-39	Cond. Low Run	0 (Off), 1 (On)			0
P-40	Cond. Low Temp.	-49.0 to 120 °C (-56.2 to 248 °F)	0.1	Deg	5
P-60	Timer Mode	0 (Local), 1 (Remote), 2 (Man Off), 3 (Man On)			Local
P-61	Sunday Time On	00:00 to 23:59	00:01	hh:mm	08:00
P-62	Sunday Time Off	00:00 to 23:59	00:01	hh:mm	20:00
P-63	Monday Time On	00:00 to 23:59	00:01	hh:mm	08:00
P-64	Monday Time Off	00:00 to 23:59	00:01	hh:mm	20:00
P-65	Tuesday Time On	00:00 to 23:59	00:01	hh:mm	08:00
P-66	Tuesday Time Off	00:00 to 23:59	00:01	hh:mm	20:00
P-67	Wednesday Time On	00:00 to 23:59	00:01	hh:mm	08:00
P-68	Wednesday Time Off	00:00 to 23:59	00:01	hh:mm	20:00
P-69	Thursday Time On	00:00 to 23:59	00:01	hh:mm	08:00
P-70	Thursday Time Off	00:00 to 23:59	00:01	hh:mm	20:00
P-71	Friday Time On	00:00 to 23:59	00:01	hh:mm	08:00
P-72	Friday Time Off	00:00 to 23:59	00:01	hh:mm	20:00
P-73	Saturday Time On	00:00 to 23:59	00:01	hh:mm	08:00
P-74	Saturday Time Off	00:00 to 23:59	00:01	hh:mm	20:00
dFLt	Restore default values				



Ensure that all power is switched off before installing or maintaining this product

Parameter Description

No.	Parameter	Description
P-01	Cut-in Temp	Temperature at which the condenser pump will start and compressor goes to pre-run
P-02	Diff	Diff below cut-in that compressor goes off and cond pump goes to run-on
P-03	Control Weight	Percentage of the Evap In Temp that is used to calculate the Control temp. The remaining percentage will be used on the Evap Out Temp Example, P-03 set to 30% Control temp = 30% Evap In Temp + 70% Evap Out Temp
P-04	Display Weight	As above only applied to the display temperature
P-05	Starts per Hour	Allows the user to set the compressor for a given number of starts/hour
P-06	Pump Reset Time	Time before evap pump retries after starting and not getting run signal
P-07	Pump Flow Detect	Period for run signal to be returned
P-08	Comp. Reset Time	The delay time after a compressor trip has cleared before the controller will attempt to restart the compressor.
P-09	Comp. OT Trip Time	The time delay between a compressor OT trip (measured by the evaporator probe) occurring and an alarm being generated.
P-10	Comp. UT Trip Time	The time delay between a compressor UT trip (measured by the evaporator probe) occurring and an alarm being generated.
P-11	Compressor Retries	The number of times the controller will attempt restart the compressor before locking it out.
P-13	Condenser Run On	Period that the condenser pump will run on for after compressor stops
P-14	Condenser Pre-Run	Period after condenser pump starts before the compressor comes on
P-20	Fault Input 1 Polarity	N/C = Open circuit for alarm N/O = Short circuit for alarm
P-21	Fault Input 2 Polarity	As above
P-22	Fault Input 3 Polarity	As above
P-26	Service Time	Time (in 1000 x hours) before the service icon (Spanner icon) comes on. The Run Hours timer increments based on the number of hours the controller has been powered up and running. Reset the spanner icon to off by changing this parameter to 0 and then back to the desired service interval. This process also resets the Run Hours value to 0. To view the current Run Time value refer to the I/O list.
P-30	Evap. In OT/UT Alarm Delay	Delay for the Evap In Temp over and under-temperature alarms
P-31	Evap. In UT Alarm	Evap In under temperature alarm set point
P-32	Evap. In OT Alarm	Evap In over temperature alarm set point
P-33	Evap. Out OT/UT Alarm Delay	Delay for the Evap Out Temp over and under-temperature alarms
P-34	Evap. Out UT Alarm	Evap Out under temperature alarm set point
P-35	Evap. Out OT Alarm	Evap Out over temperature alarm set point
P-36	Cond. OT/UT Alarm Delay	Delay for the Cond Out Temp over and under-temperature alarms
P-37	Cond. UT Alarm	Cond Out Temp under temperature alarm set point
P-38	Cond. OT Alarm	Cond Out Temp over temperature alarm set point
P-39	Cond. Low Run	Enable for frost protection
P-40	Cond. Low Temp.	Set point at which frost protection will run both pumps
P-60	Timer Mode	Allows the user to set the timer mode: - <ul style="list-style-type: none"> ➢ Always off ➢ Always on ➢ Use a local schedule P-61 to P-74) ➢ Use a remote schedule (Set up in the system front end)
P-61	Sunday Time On	When P-60 is set to Local, Sunday on time
P-62	Sunday Time Off	When P-60 is set to Local, Sunday off time
P-63	Monday Time On	When P-60 is set to Local, Monday on time
P-64	Monday Time Off	When P-60 is set to Local, Monday off time
P-65	Tuesday Time On	When P-60 is set to Local, Tuesday on time
P-66	Tuesday Time Off	When P-60 is set to Local, Tuesday off time
P-67	Wednesday Time On	When P-60 is set to Local, Wednesday on time
P-68	Wednesday Time Off	When P-60 is set to Local, Wednesday off time
P-69	Thursday Time On	When P-60 is set to Local, Thursday on time
P-70	Thursday Time Off	When P-60 is set to Local, Thursday off time
P-71	Friday Time On	When P-60 is set to Local, Friday on time
P-72	Friday Time Off	When P-60 is set to Local, Friday off time
P-73	Saturday Time On	When P-60 is set to Local, Saturday on time
P-74	Saturday Time Off	When P-60 is set to Local, Saturday off time
dFLt	Restore default values	Restores all of the parameters to their default values



Ensure that all power is switched off before installing or maintaining this product

Relay State and functional operation

Relay State:	Function State	Wired contact
Relay 1 off	Evaporator Pump Off	N/O
Relay 1 on	Evaporator Pump On	N/O
Relay 2 off	Compressor Off	N/O
Relay 2 on	Compressor On	N/O
Relay 3 off	Condenser Pump Off	N/O
Relay 3 on	Condenser Pump On	N/O
Relay 4 off	Remote Command Off	N/O
Relay 4 on	Remote Command On	N/O
Relay 5 off	Remote Command Off	N/O
Relay 5 on	Remote Command On	N/O

Note: relay 5 common is fed internally from the mains supply input.

Control Strategy

When the 7 day timer switches on to start the process, the evaporator pump is switched on. If the Evaporator Water Pressure OK input (input 4) does not become active within the Pump Flow Detect time then the pump is switched off. After the Pump Reset time has expired, the evaporator pump is started again, if the Evaporator Water Pressure OK input does not become active within the Pump Flow Detect time then the pump is switched off and an Evaporator Lock alarm is generated. The evaporator pump cannot now be started without manual intervention this is done by holding down the reset “#” key for 5 seconds. Once a manual reset has been carried out, the evaporator pump will attempt to start again.

Once the evaporator pump is running and the Evaporator Water Pressure OK input is activated within the Pump Flow Detect time, the evaporator pump will continue to run until it is switched off by the 7 day timer or if a fault condition occurs.

If the Control Temperature rises above the set-point and the evaporator pump is running then the condenser pump is switched on. After the Condenser Pre-Run time has expired and either or both of the Compressor Overload and HP/LP fault inputs are not active then the compressor will be switched on (subject to starts per hour not being exceeded). During the pre-run time or if the compressor is holding off due to the starts per hour being exceeded, the compressor led will flash. If a condenser out over temperature alarm occurs, the compressor will be turned off, followed by the condenser pump after the condenser run on time has expired. After the compressor reset time has expired, the compressor and condenser pump will attempt to restart. There is no lockout on a condenser out OT alarm.

If the Control Temperature falls below the Setpoint minus the Cut-in Diff, the compressor will be switched off and after the Condenser Run-On period has expired, the condenser pump will switch off.

If the Evaporator Water Pressure input is removed (a fault condition) while the compressor is running, the evaporator pump, the condenser pump and the compressor will be turned off. The evaporator pump will attempt one restart before an Evaporator Lock alarm is generated, the evaporator pump cannot now attempt a restart until a manual reset is performed.

If a Compressor Overload alarm or a HP/LP fault alarm is generated while the compressor is running, the compressor will be switched off and after the Condenser Run-On period has expired, the condenser pump will be switched off. The evaporator pump will continue to run as long as there is not an evaporator pressure fault condition. After the Comp. Reset Time has expired, the compressor will attempt another restart (subject to starts per hour). If the Comp. Retries parameter is exceeded then the compressor, evaporator pump and condenser pump will be turned off and cannot attempt a re-start until a manual reset is performed.
HP/LP Alarm will only clear by pressing “#” key for 5 seconds

Condenser Low Temperature (Frost Protection)

Parameter P-39 (Cond Low Run) Set to On

Parameter P-40 (Cond Low Temp) Set Point (Fixed 5 minute delay)

If the Timer is off

Cond Out Temp drops below the Set Point for 5 minutes

The evaporator pump and condenser pump run unless a fault condition occurs

The pumps will go off again when the Condenser out Temperature has risen back above the cond low temp Set Point

If the timer is On

If the compressor is running (Evap and Cond Pumps On)

Cond out Temp drops below the Set Point for 5 minutes

The compressor will switch off.

The evaporator pump and condenser pump will continue to run unless a fault condition occurs

The compressor will restart once the condenser out temperature has risen back above the Set Point

This parameter will **not** generate an alarm.



Ensure that all power is switched off before installing or maintaining this product

If the Condenser pump is off due to the control temperature being satisfied
 Cond out Temp falls below Set Point for 5 minutes
 The condenser pump will come on and run till the Cond out Temp rises above the set point again.

Flow Diagram

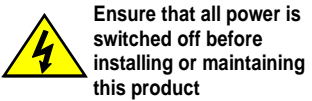
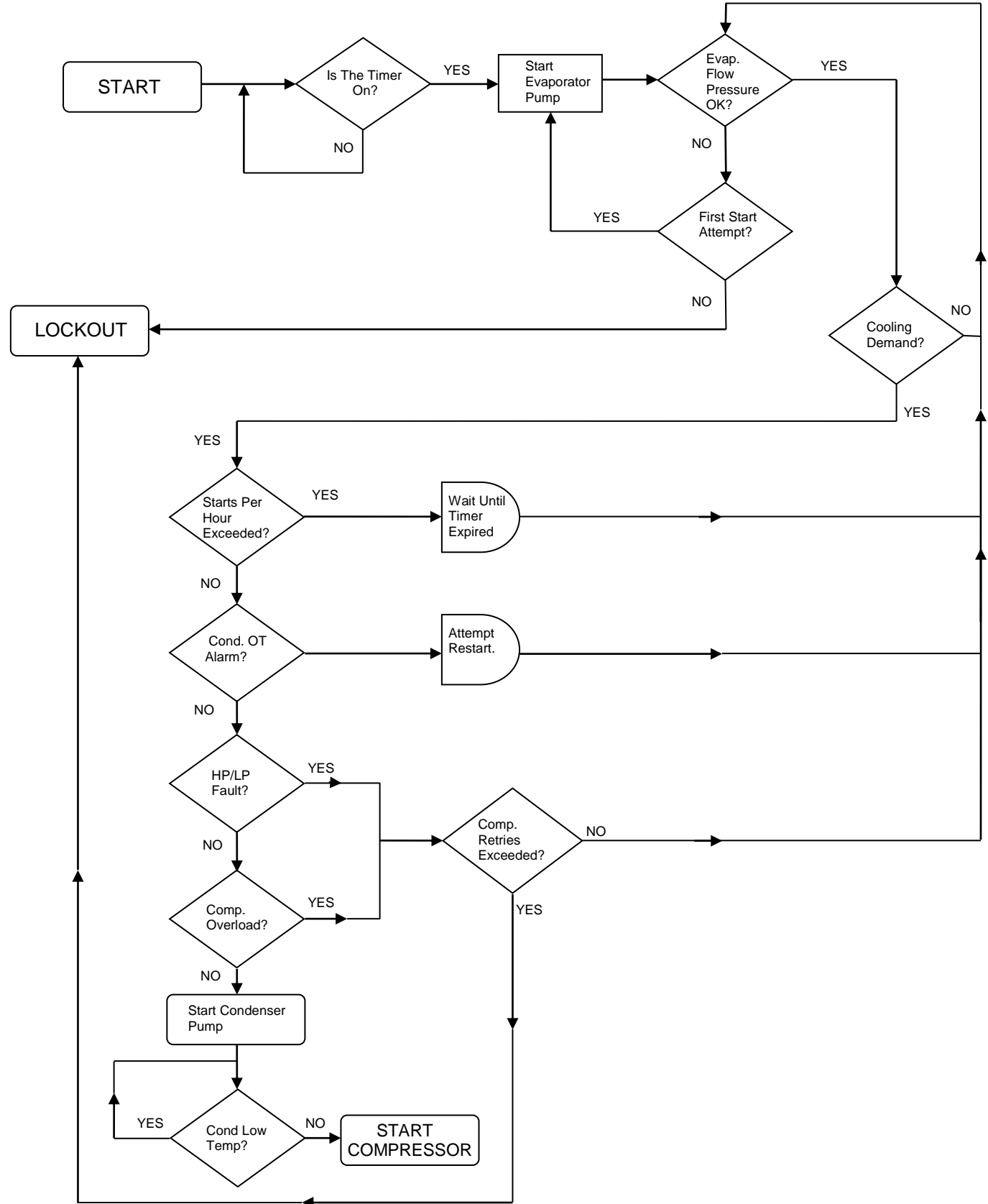

Network Configuration

The final section to setup is the network address. In all instances, this must be done before the controller is plugged into the site network. The controllers have an auto-initialise function, which will automatically log the device onto the site network. If the wrong address has been entered onto the network, you will have to reset the controller address by setting the address to 00-0, and then re-enter the correct address. (You may have to deregister the wrong address from the home system as well).

To set the controller onto a network you must first connect the controller to a communications module. This is either a : -

- 485 Legacy
- RDM Wireless Mesh System
- IP Futura
- Mercury Switch (Hub)

485 Legacy module

485 legacy support the following protocol: -

- Genus

Connecting a 485 legacy module to the controller will govern which set up screens are made available.

Display	Option
485t	485 Network Type
485A	485 Address/Name
gAdd *	Show underlying network address assigned to controller
rLog *	Re-log the controller back onto the network
CLrA *	Clear the address/name from the controller
ESC	Exit network menu. N.B. this option must be selected to save any changes made in this menu

* These options are only available when the network type is set to Genus or Wireless Mesh compatible.

The 485t option shows a value representing the network type. The possible values are:

Value	Network Type
1	Genus compatible (all versions)
2	RDM Wireless Mesh System (Wireless Mesh)

The 485A option shows a value representing either the name of the controller in a Genus compatible or Wireless Mesh network.

Wireless Mesh Communication Module

RDM Wireless Mesh System

Please refer to the RDM Wireless Mesh Communication Module user guide, which can be obtained from the RDM website, for information regarding connecting a controller to a Wireless Mesh network.

The value shown is of the form 05-6. This means the controller would try to log onto a Genus compatible or RDM Wireless Mesh network using the name 'RC05-6'.

The following options are also available when the network type is set to Genus or Wireless Mesh compatible.

The gAdd option displays (in hexadecimal format) the underlying network address assigned to the controller when it was logged onto the network.

The rLog option allows the controller to be logged back onto the network with its current name. The 'rLog' message will flash for confirmation. Press the Enter button to execute the command, Up or Down buttons to cancel.

Fast Network Address Reset

The CLrA option will clear out the network address and name in the controller. The 'ClrA' message will flash for confirmation. Press the Enter button to execute the command, Up or Down buttons to cancel.

To enter this mode, hold the Enter, Up and Down buttons together for approximately 3 seconds until the message CLrA appears on the display. CLrA is the first option in the menu consisting of the following options:



Ensure that all power is switched off before installing or maintaining this product

Display	Option
CLrA	Clear the address/name from the controller
ESC	Exit Setup mode

Pressing the Enter button to select the CLrA option will cause the 'CLrA' message to flash for confirmation, if the network type is set to Genus compatible. Press the Enter button to execute the command, Up or Down buttons to cancel. If the network type is not set to Genus compatible then the CLrA message will not flash and the ESC option can be used to exit the menu.

IP Futura module

In an IP system there are two options

- IP-L
- IP-r

IP-L allows you to fix an IP address into the controller, which you would use when you are connecting the controllers onto a customer's local area network. This would allow the customer to view each controller using Internet Explorer

IP-r allows you to give each controller on the system a unique number. This number is then allocated a dynamic IP address by the system DHCP server (such as the RDM Data Manager or Data Director)

IP-L

To configure the communication module for IP-L, set all three rotary switches to zero. The module should then be connected to the controller.

1. nEt. From the function menu you can now select nEt
 - Press enter and the display will show "IP-L", press enter
 - You can now set the address using the table below

Display	Option
IP-1	IP Address byte 1
IP-2	IP Address byte 2
IP-3	IP Address byte 3
IP-4	IP Address byte 4
nL	Network Mask Length
gt-1	Gateway Address byte 1
gt-2	Gateway Address byte 2
gt-3	Gateway Address byte 3
gt-4	Gateway Address byte 4
ESC	Exit network menu. N.B. this option must be selected to save any changes made in this menu

IP-r

To configure the communication module for IP-r, set the three rotary switches to give each controller a unique identifier. The module should then be connected to the controller and the network.

2. nEt. From the function menu you can now select nEt
 - Press enter and the display will show "IP-r", press enter
 - You can now view only the address given by the DHCP server

To ease setup, a single network mask length value is used. If the address has been specified with a network mask value in dotted IP format e.g. 255.255.255.0 then the table below gives the conversion:

Mask	Length	Mask	Length	Mask	Length
		255.255.254.0	23	255.254.0.0	15
255.255.255.252	30	255.255.252.0	22	255.252.0.0	14
255.255.255.248	29	255.255.248.0	21	255.248.0.0	13
255.255.255.240	28	255.255.240.0	20	255.240.0.0	12
255.255.255.224	27	255.255.224.0	19	255.224.0.0	11
255.255.255.192	26	255.255.192.0	18	255.192.0.0	10
255.255.255.128	25	255.255.128.0	17	255.128.0.0	09
255.255.255.0	24	255.255.0.0	16	255.0.0.0	08



Ensure that all power is switched off before installing or maintaining this product

Mercury Switch

Please refer to the Mercury Switch user guide, which can be obtained from the RDM website, for information regarding connecting a controller to a network.

Viewing

Apart from setting up the controller, you can also view the status of the inputs and outputs.

1. IO. View Inputs / Outputs and States
 - a. From the function menu, select "IO", press enter
 - b. You can now scroll through the IO tables as set out below.

Input/Output table

Number	IO	Range (dependant on probe type)	Step	Units
I-01	Control Temp.	-42 to 60 °C (-43.6 to 140 °F)	0.1	Deg
I-02	Evaporator In Temp.	-42 to 60 °C (-43.6 to 140 °F)	0.1	Deg
I-03	Evaporator Out Temp.	-49 to 60 °C (-56.2 to 140 °F)	0.1	Deg
I-04	Condenser Out Temp.	-49 to 60 °C (-56.2 to 140 °F)	0.1	Deg
I-05	Evap. Pressure / Pump Status	1 (OK), 0 (Fault) If P20=1 (N/C)	0.1	Deg
I-06	Comp. Overload Input	1 (OK), 0 (Fault) If P21=1 (N/C)	0.1	Deg
I-07	HP/LP Fault	1 (OK), 0 (Fault) If P22=1 (N/C)	0.1	Deg
O-01	Evaporator Pump	0 (Off), 1 (On)	1	
O-02	Compressor	0 (Off), 1 (On)	1	
O-03	Condenser Pump	0 (Off), 1 (On)	1	
O-04	Remote Relay 4	0 (Off), 1 (On)	1	
O-05	Remote Relay 5	0 (Off), 1 (On)	1	
O-06	Timer	0 (Off), 1 (On)	1	
O-18	Run Time	0-128	1	K Hrs.
O-30	Setpoint Offset	N/A	N/A	N/A
O-31	Setpoint	-42 to 30°C (-45 to 86 °F)	0.1	Deg
S-01	Evaporator State	Stabilise (0), Initialise (1), Off (2), Run (3), Fail (4), Retry (5), Lock (6)	1	
S-02	Compressor State	Off (0), Pre-Run (1), Run (2), Fail (3), UT Trip (4), OT Trip (5), Lock (6)	1	

Alarm Messages

The following alarms and messages can appear on the Mercury display.

Display Message	System status
Ft	Control Fault
Eloc	Evaporator Lock Out
Cloc	Compressor Lock Out



Ensure that all power is switched off before installing or maintaining this product

Network Alarms

The table below shows the text and associated type number that is sent to the system "front end". The type number is normally used to provide different alarm actions.

Alarm text	Type # (index)
Evap. In Probe Fault	6
Evap. Out Probe Fault	6
Cond. Out Probe Fault	6
Evap. Press/Pump Fault	6
Comp. Overload Fault	6
HP/LP Fault	6
Evap. In Temp. UT Alarm	4
Evap. In Temp. OT Alarm	5
Evap. Out Temp. UT Alarm	4
Evap. Out Temp. OT Alarm	5
Cond. Out Temp. UT Alarm	4
Cond. Out Temp. OT Alarm	5
Compressor Lock Alarm	15
Evaporator Lock Alarm	2

Remote Commands:

The following commands can be used by a Data Builder program: -

Command	Value to send	Description	Conditions;
Setpoint Command	$\pm 18^{\circ}$	Is added to or subtracted from the setpoint	
Haccp Command	0	HACCP LED OFF	
	1	HACCP LED On	
	2	HACCP LED Flashes	
Button Command	0	Buttons backlights Off	
	1	Buttons backlights On	
	2	Buttons Backlights Flash	

Use an "Analogue Out" block configured to the controller name and in the value field type in the command you require. Use a "Setting block" as the input to the "Analogue Out" block to send the Value.



Ensure that all power is switched off before installing or maintaining this product

Specification

	Mercury Mk2 Controller PR0710, PR0720	Intuitive Mercury controller PR0750, PR0760
Power requirements		
Supply Voltage Range	100 - 240 Vac $\pm 10\%$	100 - 240 Vac $\pm 10\%$
Supply Frequency	50 - 60 Hz	50 - 60 Hz
Maximum supply current	5.2 Amps (when relay 5 is fully loaded)	2 Amps
Typical supply current	<1 Amp	<1 Amp
General		
Operating temperature range	+5°C to +50°C	-10°C to +60°C
Storage temperature range	-20°C to +65°C	-20°C to +65°C
Environmental	Indoor use at altitudes up to 2000m, pollution degree 1, installation category II. Voltage fluctuations not to exceed $\pm 10\%$ of nominal voltage.	Indoor use at altitudes up to 2000m, pollution degree 1, installation category II. Voltage fluctuations not to exceed $\pm 10\%$ of nominal voltage.
Size	78mm (W) x 36mm (H) x 110mm (D)	157mm (W) x 67mm (H) x 120 (D)
Approx Weight	170 grams	500 grams
Safety	EN61010	EN61010
EMC	EN61326; 1997 +Amdt. A1; 1998	EN61326; 1997 +Amdt. A1; 1998
Ventilation	There is no requirement for forced cooling ventilation	There is no requirement for forced cooling ventilation
Class 2 Insulation	No protective Earth is required and none should be fitted	No protective Earth is required and none should be fitted
Supply Fuse	The host equipment must provide a suitable external over-current protection device such as: - Fuse: 6.3A 240 Vac Antisurge (T) HRC conforming to IEC 60127	Built in fuse holder, fuse 2A 240Vac Antisurge (T) HRC conforming to IEC60127, 32 x 6.3mm
Or MCB	6A, 240 VAC Type C conforming to BS EN 60898	2A, 240 VAC Type C conforming to BS EN 60898 (Note: controller has integral 2A fuse)
Relay Fuse	Not Fitted	10A 240Vac Antisurge (T) HRC conforming to IEC60127, 32 x 6.3mm
Relay Specification		
Relays 1-4 Exclusive common		
Max current	6A Resistive (Cos ϕ = 1) 2A Inductive (Cos ϕ = 0.4)	10A Resistive (Cos ϕ = 1) 3A Inductive (Cos ϕ = 0.4)
Max voltage	250Vac, 30V dc	250Vac, 30V dc
Relay Fuse	N/A	10A 240Vac Antisurge (T) HRC conforming to IEC60127, 32 x 6.3mm
Relay 5 Common connected to supply live		Relay 5 Exclusive common
Max current	3A (non inductive), COS ϕ =0.4 2A (inductive load) 200,000 operations	10A Resistive (Cos ϕ = 1) 3A Inductive (Cos ϕ = 0.4)
Max voltage	250Vac (Internal supply)	250Vac, 30V dc (external supply)
	For compliance with the LVD, relays 3, 4 and 5 commons must be at the same potential as the supply voltage	All relays are independent and can operate at different potentials to the supply voltage.

Warning: Relay 5 output has hazardous voltages (Supply input voltage potential)
This does not apply to the Intuitive Mercury controller



Ensure that all power is switched off before installing or maintaining this product

Inputs

Input resistance: 3.01K Ohms (for PTC or NTC type probes)
 Input type: PT1000 or NTC2K or NTC2K25 or NTC10K (selectable)

Comms: RS232 with flow control

Installation

Panel Cut-out and Clearances

Mercury Mk2 (Flush mount controller)

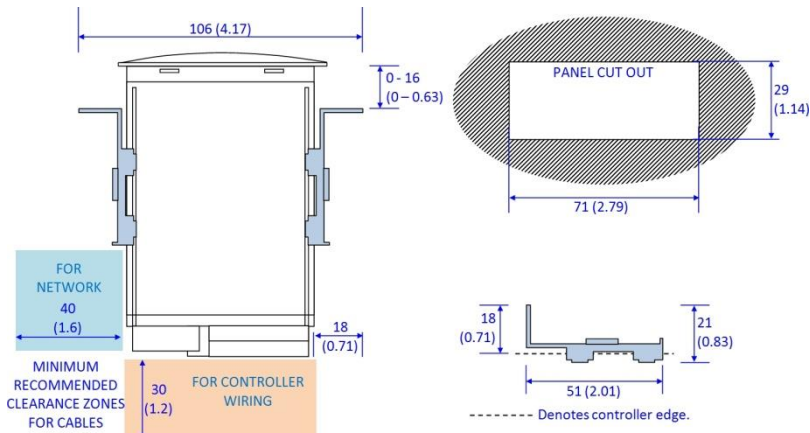

Fixing

The controller is fixed by sliding the 2 plastic retaining clips up to rear of the panel. These clips have a ratchet action and can be removed by holding in the clip sides and sliding back.

There is no requirement for forced cooling ventilation

Mercury Mk2

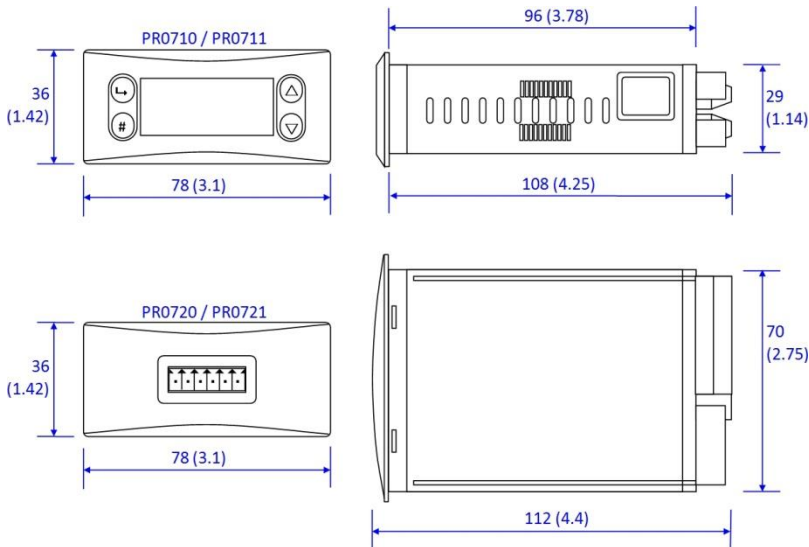

Ensure that all power is switched off before installing or maintaining this product

Dimensions

Intuitive Mercury controller

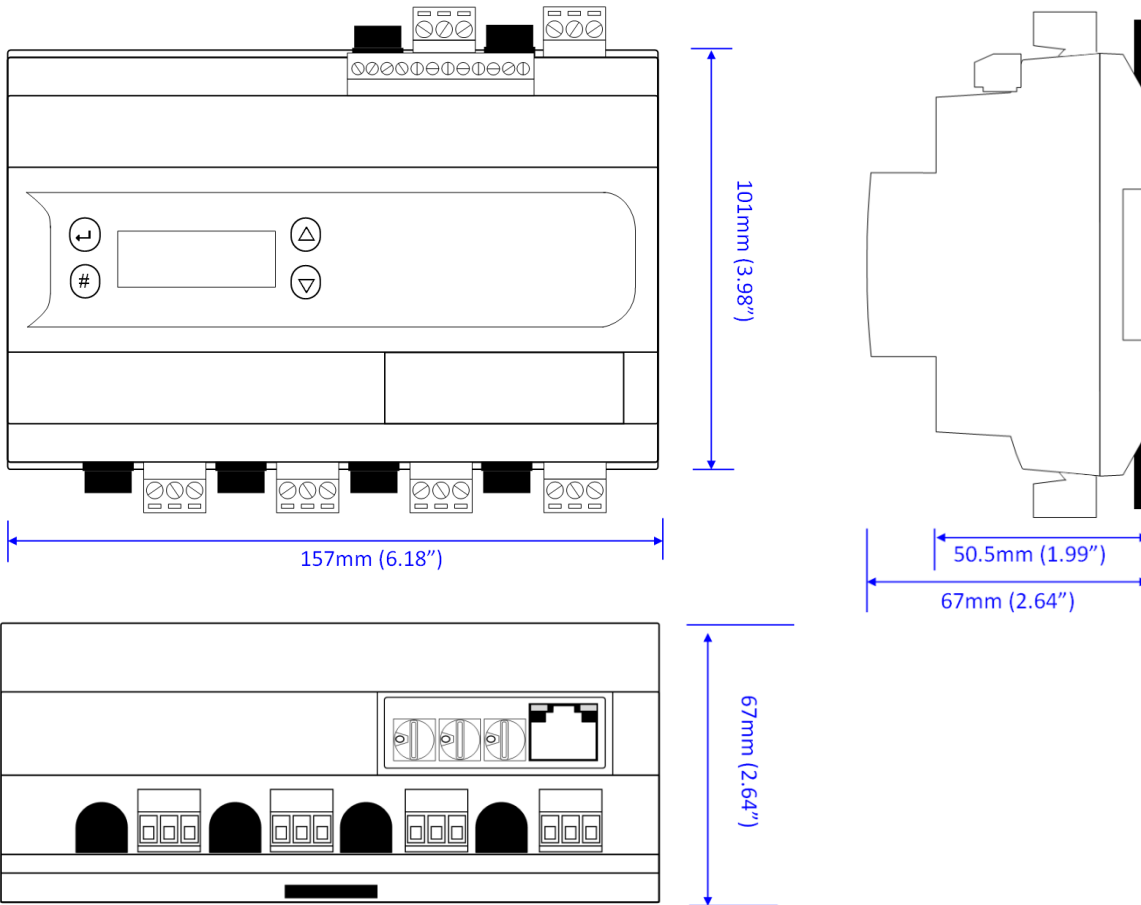

Intuitive Mercury Mounting Instructions

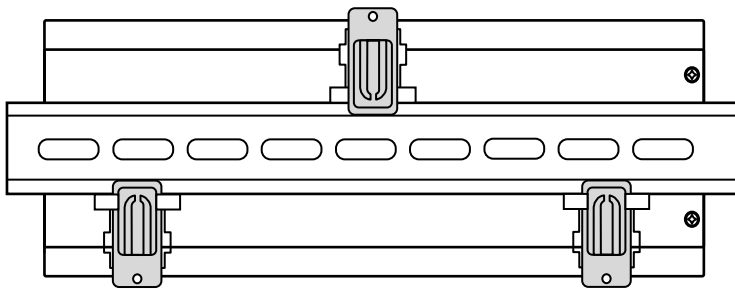

Three clips fix the Intuitive Mercury securely to DIN rail. Pull each clip until it “clicks” to remove the controller. Each clip has a mounting hole to provide an alternative fixing mechanism to DIN mounting.

Cleaning

Do not wet the controller when cleaning. Clean the front by wiping with slightly dampened lint free cloth.

Disclaimer

The specifications of the product detailed in this document may change without notice. RDM Ltd shall not be liable for errors or omissions, for incidental or consequential damages, directly or indirectly, in connection with the furnishing, performance or misuse of this product or document.

Revision History

Revision	Date	Changes
1.8	01/06/2014	First Issue
1.8a	23/12/2014	Intuitive operating temperature altered.



Ensure that all power is switched off before installing or maintaining this product