

Contents

The Mercury & Intuitive Mercury Range.....	4
Hardware Variants	4
Displays and Accessories	4
Compatible Network Interfaces.....	5
Configuration	5
Front Display Features.....	6
Mercury Display	6
Coldroom Display	7
Mercury Stepper I/O Connections	8
Intuitive Mercury Stepper I/O Connections.....	9
Intuitive Mercury Network Expansion Options	9
Intuitive Mercury Stepper with Daughter Board Option.....	10
Intuitive Mercury Daughter Board Connection Details	10
Input and Output Allocation Tables	11
Mercury & Intuitive Stepper 24v Hardware	11
Intuitive Mercury Stepper 240v Hardware	12
Switched Resistor Values.....	13
Ordering Information	14
Mercury Stepper Controller 24v Hardware	14
Intuitive Mercury Stepper Controller 24v Hardware	14
Intuitive Mercury Stepper Controller 240v Hardware.....	14
Setting up the controller	15
Setup through front buttons	15
Setup Function Menu (Common to all types).....	15
Recommended set-up method	16
rtc. Real time clock (This will automatically synchronise on network systems).....	16
type. Set/view controller type.....	16
PArA. Set/view parameters (This can be achieved at the network front end).....	16
Unit. Set/view temperature unit and Probe type	16
diSP. Display Selection.....	17
dtyP. Set/ view Display Type	17
Parameter Tables – 24v Variant.....	17
Refrigerant Table for P-31	20
Parameter Tables – 240v Variant	21
Refrigerant Table for P-59	24
Parameter Descriptions.....	24
Holding Current	29
Half Step.....	29
Stepper Valve Type	29
Valve Wiring	30
Valve State – Overdriving.....	30
Stepper Valve Control Using Pressure	31
Maximum Operating Pressure (MOP).....	31
Ref. Weighting	31
Relay State and functional operation.....	32
Relay and screen states during defrost.....	32
Defrost Termination.....	32
Fan Delay after Defrost	32
Network Configuration.....	33
Mercury RS232 Variant & Intuitive Mercury	33
RS485 module/ Intuitive Internal RS485 Network card	34
Mercury IP Variant	34
Viewing IO	36
Input / Output Table.....	36
Display Messages.....	37
Network Alarms.....	37
Modifying controller states	38
Fans Only 'FanS'	38
Case Off 'CASE'	38
Lights Only 'Ligt'	38
Probe Offset.....	38
Remote Commands.....	39
Specification	40
Installation & Dimensions	42
Panel Cut-out and Clearances	42
Fixing	42
Dimensions – Mercury	42
Dimensions – Intuitive Mercury Controller.....	43



Please ensure all power is switched off before installing or maintaining this product.

Intuitive Mercury Mounting Instructions	43
Cleaning	43
Appendix 1: Defrost Cycles.....	44
Appendix 2: Trim Heater Control via Mercury/ Intuitive Range	45
Appendix 3: Step Speed (Frequency Hz)	45
Appendix 4: Webpage Appearance	46
Inputs & Outputs.....	46
Parameters.....	47
Alarms	47
Configure	48
Time.....	48
Parameters.....	49
Controller Type	49
Temperature Units	50
Pressure Units	50
Display Units	50
Remote Defrost.....	50
Name	50
Logging.....	51
Asset Information.....	51
Probe Offsets.....	52
Disclaimer	52
Revision History	52



Please ensure all power is switched off before installing or maintaining this product.

The Mercury & Intuitive Mercury Range

From Resource Data Management

IMPORTANT: The low voltage variant uses a 24v AC or DC power supply. If used in conjunction with an Intuitive power store (PR0627) the supply must be DC only.

The Mercury and Intuitive Mercury Stepper Case controllers are used to drive a Stepper Valve based on input readings from local probe or pressure inputs.

The Mercury Stepper Controller is primarily intended for use in refrigeration display cabinets or coldroom applications. It has outputs to control lights, fans, suction valve, trim heaters and defrost control. In the Mercury variant there is an analogue input (4-20mA or 0-10V) for reading a suction pressure transducer, two digital inputs in addition to the original Mercury switched resistor digital input feature

The Intuitive variant is a DIN rail mounted version designed to be used in a control panel or electrical tray. This range has similar features to the Mercury controller with benefits such as higher rated relays each protected by an optional integral fuse. The intuitive offers an option for an internal daughter card to read a suction pressure transducer (4-20mA or 0-10V) which can then be converted to the evaporator in temperature for use in calculating superheat.

Both the Mercury and Intuitive (fitted with daughter card) can be used with the Intuitive Power Store (PR0627) which provides a backup power supply which enables the valve to be fully closed in the event of a power failure. All connections are plug and socket and there are multiple network interfaces to choose from including IP and RS485.

The controller has many features, some of which are energy saving, such as pulsed trim heaters or the case off with lights parameter (see parameter section for further details). There are several hardware variants of the Stepper Case Controller including; panel or DIN rail mount, serial or IP communications, power supply along with either a remote or integral display option (see [Ordering Information](#) for more details).

The controller supports; PT1000, NTC2K, 470R, 700R, 3K, 5K, 6K, NTC2K25, NTC10K or NTC10K (2) temperature probes. **Note:** probe types cannot be mixed.

Hardware Variants

Description	Part Number
Mercury Stepper Valve Case Controller (24v Supply)	PR0740 SX XX STEP
Intuitive Mercury Stepper Valve Case Controller (24v Supply)	PR07X2
Intuitive Mercury Stepper Valve Case Controller (mains Supply)	PR095X XXX

Further hardware options including; display, power supply and comms can be selected. Please see [Ordering Information](#) for all options.

Displays and Accessories

The following optional displays and accessories are available;

Description	Part Number
Mercury DIN Remote Display with 5m cable	PR0327
Mercury DIN Key switch Remote Display with 5m cable	PR0328
Mercury Mk2 Remote Display with 5m cable	PR0725
Mercury Coldroom Display	PR0152
Intuitive Power Store (shuts the valve in the event of a power fail)	PR0627
Stepper Filter module (should be used if the standard stepper valve cable is extended)	PR0656
Pressure Transducer -1 to 20 bar with 1/4in NTP male fitting	PR0160
Pressure Transducer -1 to 20 bar 7/16in 20UNF(F) Schrader deflator	PR0161
Pressure Transducer -1 to 65 bar with 1/4in NTP male fitting	PR0162
Pressure Transducer -1 to 65 bar 7/16in 20UNF(F) Schrader deflator	PR0163



Please ensure all power is switched off before installing or maintaining this product.

Compatible Network Interfaces

Mercury and Intuitive Mercury controllers are capable of connecting to either a TCP/IP local area network, an RS485 Genus compatible network or they can be used in standalone mode with no network output. For connection to a network it must have the correct communications module. Connecting to any of these communication modules will automatically be detected on power up and will affect the '[Net](#)' menu set up screens available.

Mercury & Intuitive Mercury controllers with an RS232 connection can use the following communication interfaces;

Description	Part Number
IP Futura (Single Mercury to IP Interface)	PR0016
RS485 Interface (Single Mercury to RS485 Interface)	PR0026
Mercury IP Switch (IP support for 10 controllers)	PR0018
Mercury IP Switch with Pressure/Humidity Inputs	PR0018-PHI

The Intuitive Mercury Controller is supplied as standard with an internal RS232 network card, this allows connection to any of the above external network interfaces. Alternative internal network cards are also available, these can be supplied factory fitted as an option or purchased separately as an interface kit;

Description	Part Number
Intuitive Internal IP Network Card Interface Kit	PR0770
Intuitive Internal RS485 Network Card Interface Kit	PR0771

Controllers with built-in IP will be able to communicate to any IP switch, including the rear ports of the RDM Mercury Hub.

Configuration

The controller gives you up to four configuration options (see '[Type](#)' menu);

Display value	Controller Type
3	Remote piped case controller (LT)
4	Remote piped case controller (HT)
5	Coldroom controller (LT)
6	Coldroom controller (HT)



Please ensure all power is switched off before installing or maintaining this product.

Front Display Features

Mercury Display

LEDs:

Valve (Stepper) 

Fans 

Lights 

Defrost 

On-Line Status 

- Off: No network attached
- Flashing: Attempting to Log on to network
- Steady: On-line

Service (See P-18) 

Alarm 

HACCP 



Keys



Enter

Up

Down

Defrost

Note: Function keys illuminate when pressed, illumination is turned off 20 seconds after the key is used.

Defrost: Press and hold the defrost button to force a manual defrost

Main Display

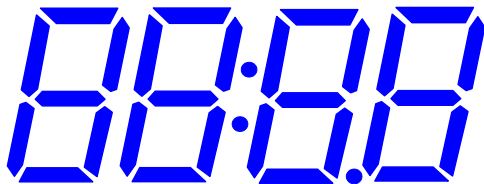

4 character blue LED display, used to display temperature and status messages.



Please ensure all power is switched off before installing or maintaining this product.

Coldroom Display

The below display represents the remote Mercury Coldroom (PR0152) remote display

LED's:

Valve (Stepper) 

Fans 

Lights 

Defrost 

On-Line 



Off: No network attached
 Flashing: Attempting to Log on to network
 Steady: On-line

Service 

Alarm 

HACCP 

Keys



Note: Press and hold the defrost button to force a manual defrost

Main Display

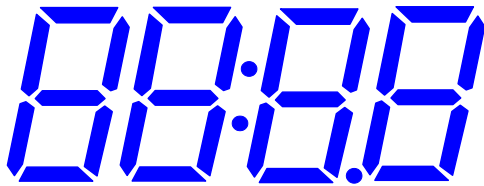

4 character blue LED display, used to display temperature and status messages.



Please ensure all power is switched off before installing or maintaining this product.

Mercury Stepper I/O Connections

Input and Output connections are made to the back of the controller, the RS232/ Ethernet communication port is on the side. The diagram below shows the connection detail. Inputs and outputs are assigned according to the chosen configuration. See [Input/ Output](#) tables for further details on connections. Below also shows you the transducer connections available.

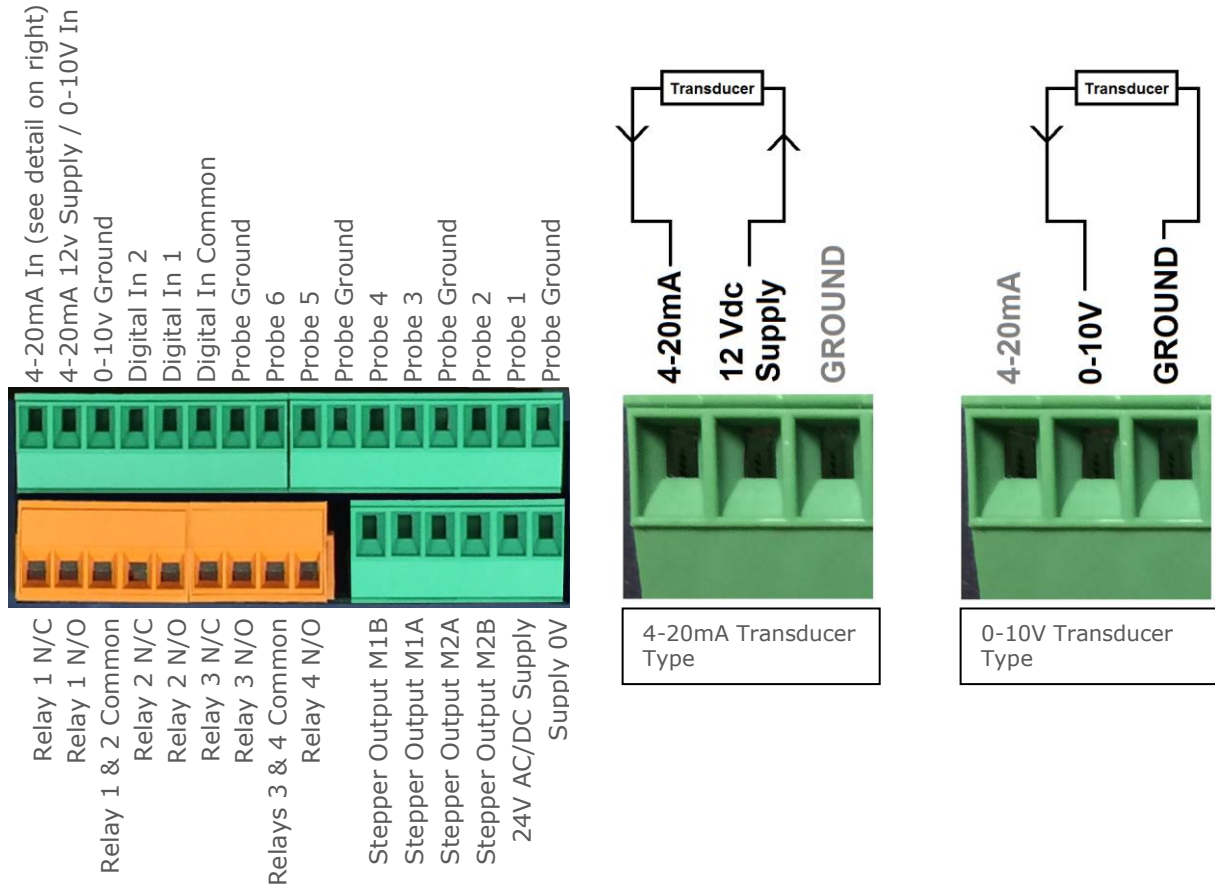

For Input Output allocation please see [Input and Output allocation tables](#).



Please ensure all power is switched off before installing or maintaining this product.

Intuitive Mercury Stepper I/O Connections

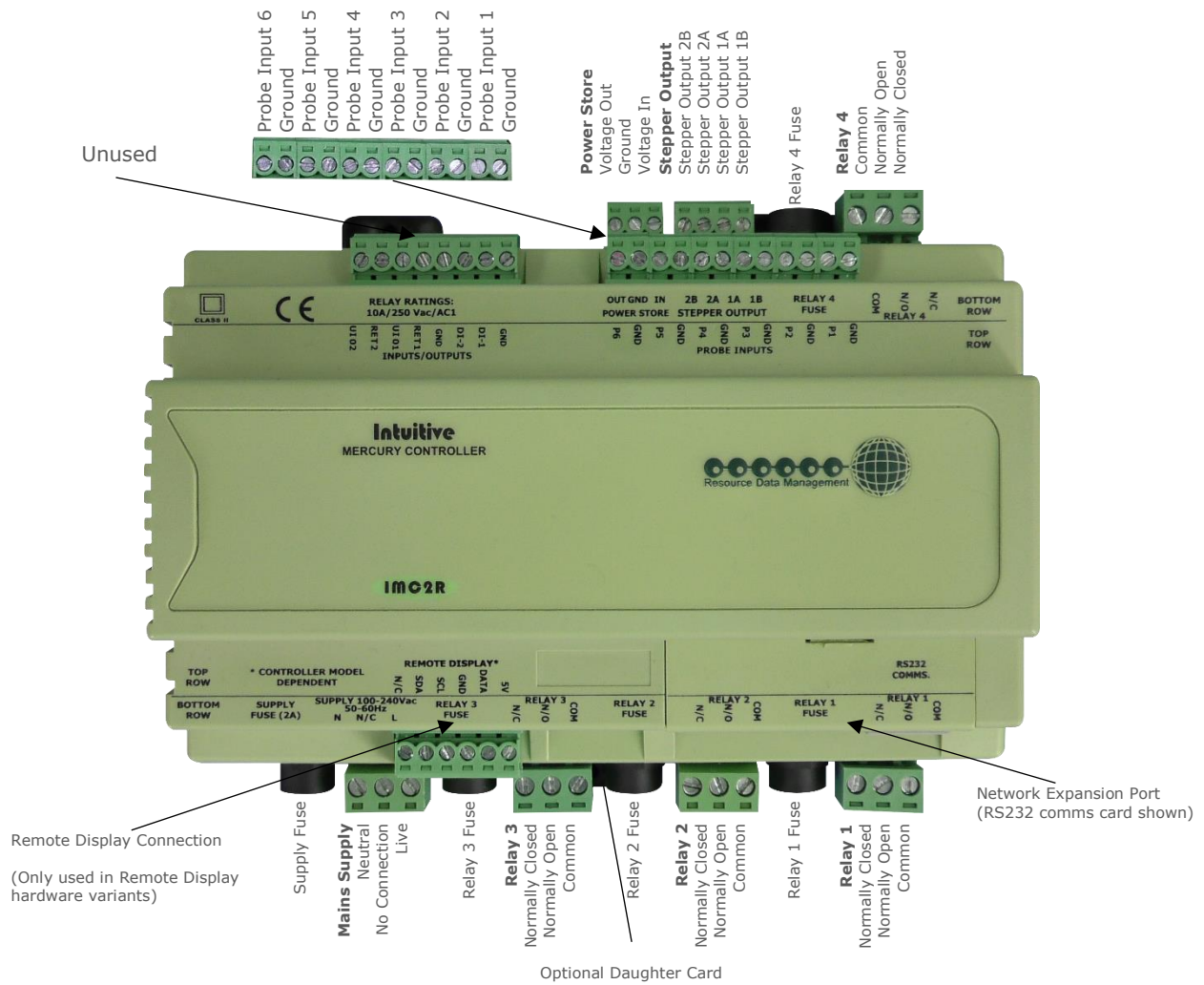

For Input Output allocation please see [Input and Output allocation tables](#).

Intuitive Mercury Network Expansion Options

RS232 Network Card (Default)



The Intuitive Mercury is supplied with an RS232 Network Card fitted as standard.

RS485 Network Card (PR0771)



Ground B- Ground A+ Screen Network Activity LED

IP Network Card (PR0770)

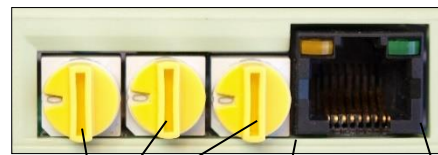

Rotary Address Switches Network Collision LED Network Activity LED



Please ensure all power is switched off before installing or maintaining this product.

Intuitive Mercury Stepper with Daughter Board Option

The Intuitive Mercury Stepper controller can be purchased with an optional daughter board to read a suction pressure. The pressure is then used in calculating a remote evaporator temperature to then calculate superheat.

Please note the daughter boards are a factory fit option only and must be ordered with the controller. Please see [ordering information](#) for more details.

Daughter Board Options	Part	Colour
1 x 0-10Vdc Input & 1 x 0-10Vdc Output* board	ViVo	Blue
1 x 4-20mA Input & 1 x 4-20mA Output* board	AiAo	Black
1 x 0-10Vdc Input & 1 x Probe Input Expansion board	1PVi	Blue
1 x 4-20mA Input & 1 x Probe Input Expansion board	1PAi	Black

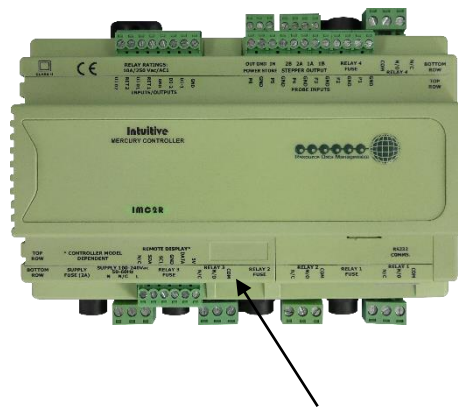

Daughter card location (Optional)

***Note:** Only 0–10V or 4–20mA Inputs used in this application (Outputs are not used). Each daughter board comes with a colour coded connector as a visual indication.

Intuitive Mercury Daughter Board Connection Details

1 x 0-10Vdc Input &
1 x 0-10Vdc Output



1 x 4-20mA Input &
1 x 4-20mA Output

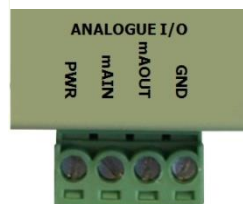

1 x 0-10Vdc Input &
1 x Probe Input

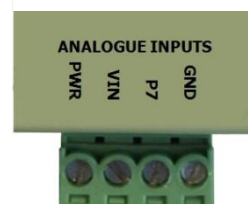

1 x 4-20mA Input &
1 x Probe Input

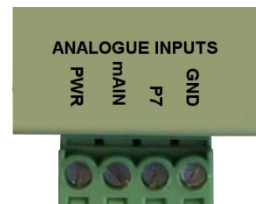

Note: 'PWR' is a constant voltage output for external equipment, supply voltage is dependent on the board type, see the specification section for more details. GND is a common ground for all inputs and outputs. As an example, if using an RDM 4-20mA pressure transducer (PR0160-PR0164), the 12vdc supply (red wire) would be connected to the 'PWR' terminal and the 4-20mA return signal (green wire) would be connected to the 'mA IN' terminal.



Please ensure all power is switched off before installing or maintaining this product.

Input and Output Allocation Tables

The following tables indicate, on a controller type basis, the function of the inputs and outputs. Also shown, are the digital inputs that are derived by switching in a fixed value resistor across the input (for more details see [Switched Resistor Values](#)).

Mercury & Intuitive Stepper 24v Hardware

Type	Remote Case Controller Types 3 & 4	Coldroom Controller Types 5 & 6	Alarm Action	Switched Resistor Input
Input 1	Air on Temperature	Air on Temperature	Yes	Selectable; - Plant 3 N/O - Plant 3 N/C - Defrost
Input 2	Air off Temperature	Air off Temperature	Yes	Case Clean
Input 3	Evaporator Temperature	Evaporator Temperature	No	
Input 4	Suction Line Temperature	Suction Line Temperature	No	
Input 5	Selectable; - Defrost Termination - Monitor probe	Selectable; - Defrost Termination - Monitor probe	Conditional*	Door switch on types 5 & 6
Input 6	Logging Probe (If fitted)	Logging Probe (If fitted)	Conditional**	Person Trapped Alarm types 5 & 6
Input 7	Valve Shut Input Note: Only when 1P/Vi or 1PAi daughter card fitted to Intuitive hardware.	Valve Shut Input Note: Only when 1P/Vi or 1PAi daughter card fitted to Intuitive hardware.	Yes	
Variable Input	4-20mA Transducer Or 0-10V Transducer	4-20mA Transducer Or 0-10V Transducer	If Transducer Is Used	
Digital 1	Selectable; - Plant 1 N/O - Plant 1 N/C - Case Switch - Temp Switch - Defrost - Shut Input	Selectable; - Plant 1 N/O - Plant 1 N/C - Case Switch - Temp Switch - Defrost - Shut Input - Door Switch - Man Trap	Conditional	
Digital 2	Selectable; - Plant 1 N/O - Plant 1 N/C - Case Switch - Temp Switch - Defrost - Shut Input	Selectable; - Plant 2 N/O - Plant 3 N/C - Case Switch - Temp Switch - Defrost - Shut Input - Door Switch - Man Trap	Conditional	
Relay 1	Fans	Fans	N/A	
Relay 2	Selectable; - Lights - Alarm	Selectable; - Lights - Alarm	N/A	
Relay 3	Selectable; - Suction Line Valve - Trim Heater - Alarm Relay - Remote Relay - Trim Hub - Liquid Line Valve	Selectable; - Suction Line Valve - Alarm Relay - Remote Relay - Liquid Line Valve	N/A	
Relay 4	Defrost	Defrost	N/A	
Stepper Output	Stepper Motor Valve	Stepper Motor Valve	N/A	

* Probe will alarm if set to monitor probe in parameters.

** Probe will alarm if log probe type is set to 'Logging/Alarm' in parameters.



Please ensure all power is
switched off before installing
or maintaining this product.

Intuitive Mercury Stepper 240v Hardware

Type	Remote Case Controller Types 3 & 4	Coldroom Controller Types 5 & 6	Alarm Action	Switched Resistor Input
Input 1	Air on Temperature	Air on Temperature	Yes	Selectable; - Plant - Defrost
Input 2	Air off Temperature	Air off Temperature	Yes	Case Clean
Input 3	Evaporator Temperature	Evaporator Temperature	No	
Input 4	Suction Line Temperature	Suction Line Temperature	No	
Input 5	Selectable; - Defrost Termination - Monitor probe - Logging Probe	Selectable; - Defrost Termination - Monitor probe - Logging Probe	Conditional*	Door switch on types 5 & 6
Input 6	Valve Shut Input	Valve Shut Input	Yes	
Input 7	Logging Probe Note: Only when 1P/Vi or 1PAi daughter card fitted	Selectable***; - Logging Probe - Door Switch Note: Only when 1P/Vi or 1PAi daughter card fitted	Conditional**	
Variable Input	4-20mA Transducer Or 0-10V Transducer	4-20mA Transducer Or 0-10V Transducer	If Transducer Is Used	
Relay 1	Fans	Fans	N/A	
Relay 2	Selectable; - Lights - Alarm	Selectable; - Lights - Alarm	N/A	
Relay 3	Selectable; - Suction Line Valve - Trim Heater - Alarm Relay - Remote Relay - Trim Hub - Liquid Line Valve	Selectable; - Suction Line Valve - Alarm Relay - Remote Relay - Liquid Line Valve	N/A	
Relay 4	Defrost	Defrost	N/A	
Stepper Output	Stepper Motor Valve	Stepper Motor Valve	N/A	

* Probe will alarm if set to monitor probe in parameters.

** Probe will alarm if log probe type is set to 'Logging/Alarm' in parameters.

*** Two inputs cannot be wired in. The input is either a Logging Probe **or** Door Switch.



Please ensure all power is switched off before installing or maintaining this product.

Switched Resistor Values

The switched resistor functionality can be turned on and off within the parameter section (P-19). When switched on, it adds the benefit of adding further digital inputs on the temperature probe inputs using fixed resistors. For wiring please see the '[Switched Resistor Wiring](#)' section. When a resistor is switched across the appropriate input, it signals to the Mercury controller to enable the switched resistor function (described for that input) while still recording the probe temperature of the input.

For the function to work, it requires specific resistors depending on the probe type used;

Probe Type	Resistor
PT1000	820Ω
NTC2K, NTC2K25, 3K	590Ω
5K, 6K	1kΩ
NTC10K	2k7Ω
NTC10K(2)	2k2Ω

The resistors used must have a tolerance of 1% or better and the resistor must have a power rating of 0.25W. For improved accuracy while using switched resistors RDM recommend resistors with 0.1% accuracy are used.

Note: the switched resistor features will **not** function when using 470R or 700R probes.

The temperature range for all probe types for probe inputs which do not have a secondary function (switched resistors) is -49°C to +128°C.

Inputs which have used the secondary (digital) function are restricted to -42°C to +60°C. If the full temperature range is required on all inputs and no switch resistor features are needed then please see Switch Resistor parameter P-19.

Note: switched resistors will operate in LT (Low Temperature) and HT (High Temperature) applications using PT1000, NTC2K or NTC2K25 probe types only. For all other probe types the switched resistor inputs will work in HT applications only.

Switched Resistor Example Wiring

Example of resistor fitted on a probe input.

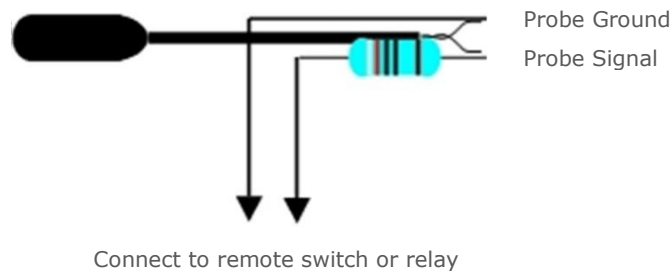

Please ensure all power is switched off before installing or maintaining this product.

Ordering Information

Mercury Stepper Controller 24v Hardware

When ordering a Mercury controller the following ordering scheme can be used to purchase the desired hardware configuration.

PR0740 S Y Z STEP

Y	Description	Z	Description
D	Local/ Integral Display	IP	Ethernet Comms
R	Remote Display	232	RS232 Comms

Example: To order a Mercury controller with Stepper Valve, Remote display and IP comms;

PR0740 S R IP STEP

Intuitive Mercury Stepper Controller 24v Hardware

When ordering an Intuitive Mercury 24v hardware variant the following ordering scheme can be used to purchase the desired hardware configuration.

PR07W2 X Y Z

W	Description	X	Description
5	Local/ Integral Display	Blank	Fused
6	Remote Display	NF	Non-Fused

Y	Description	Z	Description
Blank	RS232 Comms port	AiAo	mA Analogue Input card
IP	IP Comms port	ViVo	V Analogue Input card
		1PAi	1 Probe & mA Analogue Input card
		1PVi	1 Probe & V Analogue Input card

Example: To order an Intuitive Mercury controller 24v with Stepper Valve, Remote display, IP comms and a 1 Probe with mA Input daughter card;

PR0762 IP 1PAI

Intuitive Mercury Stepper Controller 240v Hardware

When ordering an Intuitive Mercury 240v hardware variant the following ordering scheme can be used to purchase the desired hardware configuration.

PR095V W X Y Z

V	Description	W	Description
2	Integral Display & Fused	Blank	Fused
4	Remote Display & Fused	NF	Non-Fused
6	Integral Display & Non-Fused		
8	Remote Display & Non-Fused		

X	Description	Y	Description
Blank	Local/ Integral Display	Blank	RS232 Comms port
R	Remote Display	IP	IP Comms port

Z	Description
AiAo	mA Analogue Input card
ViVo	V Analogue Input card
1PAi	1 Probe & mA Analogue Input card
1PVi	1 Probe & V Analogue Input card

Example: To order an Intuitive Mercury controller 240v with Stepper Valve, Remote display, IP comms and a 1 Probe with mA Input daughter card;

PR0954 R IP 1PAI



Please ensure all power is switched off before installing or maintaining this product.

Setting up the controller

Access to the controller can be achieved by several ways;

Serial Communications Variant

- Through the front mounted buttons of the display.
- Direct access by PC into the serial comms port. This requires a software package available on the RDM website.
- Through the RDM Data Manager.
- Across an IP network with a comms module (Current controller IP address required).

Ethernet Communications Variant

- Through the front mounted buttons of the display.
- Across an IP network (Current controller IP address required).
- Through the Data Manager.

Setup through front buttons



To enter setup mode, hold the **Enter** and **Down** buttons together for approximately 3 seconds until the message 'Ent' appears on the display. Now press the Enter button again to enter the function menu. IO will be displayed. Scroll up or down to go through the list.

Setup Function Menu (Common to all types)

Display	Option	Explained in Paragraph	Display	Option	Explained in Paragraph
IO	View Inputs/ Outputs and States	Input / output table	SoFt	View software version	
PARA	Set/ View Parameters	Set view parameters	FANS	Toggle Fans Only mode	Fans Only
Unit	Probe type and Celsius/ Fahrenheit option	Set View Unit	CASE	Toggle Case Off mode	Case Off
diSP	Display whole units or decimal	Display	Ligt	Toggle Lights Only mode	Lights Only
dtyP	Display Type	Display Type	OFSt	Probe Offset	Probe Offset
tyPE	Set/ View Controller Type	Set/view controller type	tEST*	Test Mode	See Note Below
rtc	Set/ View Clock (rtc = Real Time Clock)	Real Time Clock	ESC	Exit Setup mode	
nEt	Set/ View network configuration	Network Configuration			

***Note:** When first powered up, the controller will have the 'tEST' option in the menu setup. This allows the user to toggle the relays for testing purposes. Upon entering the menu, the display will show r-01 (relay 1) to r-05 (relay 5), select the desired output and toggle the value from 0 to 1 (confirm by pressing enter) to switch the selected relay.

This option is only available for 30 seconds after power up. After this time, the menu setup will return to its standard options.



Please ensure all power is switched off before installing or maintaining this product.

Recommended set-up method

If the controller is not connected to a network and is required to be setup through the front buttons we recommend you use the following order from the function menu.

rtc. Real time clock (This will automatically synchronise on network systems)

- Use the up or down buttons to scroll through the display until the display reads 'rtc'
- Press enter. The display will show 't-1'. press enter again
- Scroll hours up or down (0 – 23) press enter
- Use up button to select 't-2', press enter
- Scroll minutes up or down (0 – 59) press enter
- Repeat for t-3 (seconds 0 – 59)
- Repeat for t -4 (Days up to 31)
- Repeat for t -5 (months up to 12)
- Repeat for t -6 (Year up to 99)
- Use up button to display 'ESC', press enter to display 'rtc'

Time clock is now set

type. Set/view controller type

- From the function menu scroll to select 'type', press enter
- Use the up/ down buttons to scroll through case/ coldroom configuration types. (see [configuration table](#) on page 4)
- Press enter.
- Scroll to select 'ESC'
- Press enter

Controller type configuration is now set

PArA. Set/view parameters (This can be achieved at the network front end)

- From the function menu, scroll to select 'PArA'
- Pressing Enter while PArA is displayed will enter the parameter menu.
- The first parameter option will be displayed as P-01. Pressing the Up or Down button will present the other parameter options P-02, P-03 etc. See the [parameter list](#) below to find what parameter number corresponds to which actual parameter.
- Pressing the Enter button will show the current value of the selected parameter.
- Press Up or Down to modify the value and press Enter again to save the value.
- The parameter list number will be displayed again.
- Two other options are present in the parameter menu – dFLt and ESC. Selecting ESC will exit the setup mode and save all changes.
- Selecting dFLt will reset all parameters back to the default values for the current type of controller

Unit. Set/view temperature unit and Probe type

From the function menu scroll to, and select Unit. Press enter and the value will be displayed;

Probe Types

Use the up or down keys to select the units and press enter.

Option	Description	Option	Description
0	0 for PT1000 Celsius	11	11 for NTC2K25 Fahrenheit
1	1 for PT1000 Fahrenheit	12	12 for 5K Celsius
2	2 for NTC2K Celsius	13	13 for 5K Fahrenheit
3	3 for NTC2K Fahrenheit	14	14 for 6K Celsius
4	4 for 470R Celsius	15	15 for 6K Fahrenheit
5	5 for 470R Fahrenheit	16	16 for NTC10K Celsius
6	6 for 700R Celsius	17	17 for NTC10K Fahrenheit
7	7 for 700R Fahrenheit	18	18 for NTC10K(2) Celsius (USA NTC10K)
8	8 for 3K Celsius	19	19 for NTC10K(2) Fahrenheit (USA NTC10K)
9	9 for 3K Fahrenheit		
10	10 for NTC2K25 Celsius		

This function is now complete



Please ensure all power is switched off before installing or maintaining this product.

diSP. Display Selection

From the function menu scroll to and select 'diSP'. Press enter and one of the following values will be shown:

- 0:** Controller display will show the whole number and tenths value of a temperature reading. (Default)
- 1:** Controller display will show temperatures as a whole number.

dtYP. Set/ view Display Type

From the function menu scroll to and select dtYP. Press enter and one of the following values will be shown: -

- 0:** Controller will be set to use a Mercury display.
- 1:** Controller will be set to use a Coldroom display.

Note: The software defaults to 0 for the Mercury display. If using a Mercury 1 display, changing from type 1 to 0 needs to be done through the webpage and can't be done through the display.

Parameter Tables – 24v Variant

Not all parameters apply to all controller types. For example P-80 is the Door Alarm Delay which only applies to the types 5 & 6. This parameter will not appear if the controller is set to types 3 or 4 (Case controller). In the following table, the type columns on the right hand side will be greyed out if that parameter does not apply to that controller type.

Number	Parameter	Range °C (°F)	Step	Units	Default LT °C (°F)	Default HT °C (°F)	Type 3 & 4	Type 5 & 6
P-01	Cut-in Temp.	-42 to 30 (-43.6 to 86)	0.1	Deg	-20.0 (-4)	0.0 (32)	✓	✓
P-02	Diff.	0 to 10 (0 to 18)	0.1	Deg	2.0 (3.6)	1.5 (2.7)	✓	✓
P-03	Control Weight	0 to 100	1	%	50	50	✓	✓
P-04	Display Weight	0 to 100	1	%	50	50	✓	✓
P-05	Alarm Weight	0 to 100	1	%	0	0	✓	✓
P-08	Superheat Ref	4 to 12 (7.2 to 21.6)	0.1	Deg	6 (10.8)	6 (10.8)	✓	✓
P-09	Response On	1 to 30	1		10	10	✓	✓
P-10	Response Off	1 to 30	1		10	10	✓	✓
P-11	Control Type	0: EEV 1: EET 2: EEV/EET	1		0	0	✓	✓
P-51	EEV Min Opening	0 to 100	1	%	10	10	✓	✓
P-52	Superheat Problem	0 to 12 (0 to 21.6)	0.1	Deg	0.0	0.0	✓	✓
P-53	Superheat EEV Problem Opening	0 to 100	1	%	10	10	✓	✓
P-54	Superheat EEV Problem Time	00:00 to 99:00	01:00	mm:ss	03:00	03:00	✓	✓
P-56	EEV Start Opening	0 to 100	1	%	50	50	✓	✓
P-55	Ave Valve Opening	0 to 100	1	%	100	100	✓	✓
P-57	EEV Divide Value	0 to 100	1	%	50	50	✓	✓
P-12	Relay 3 Mode (Case)	0: Suction Line 1: Trim Heater 2: Alarm 3: Remote 4: Trim Hub 5: LLV	1		0	0	✓	
	Relay 3 Mode (Coldroom)	0: Suction Line 1: Alarm, 2: Remote 3: LLV	1		0	0		✓
P-13	Trim in Defrost	0: Off 1: On	1		0	0	✓	
P-14	Trim Level	0 to 100	1	%	100	100	✓	
P-85	Key-switch Mode	0: Case Off	1		3	3	✓	✓



Please ensure all power is switched off before installing or maintaining this product.

		1: Fans only 2: toggle 3: Key Off						
P-87	Control Probe type	0: Use Air on Probe 1: Use Log Probe	1		0	0	✓	✓
P-90	Resistor Case Off	0: Disabled 1: Enabled	1		0	0	✓	✓
P-92	Fans temperature mode	0: Off 1: Temperature 2: Over-temperature 3: Temp/ OT	1		0	0	✓	✓
P-93	Fans Off Temperature	-42 to 30 (-43.6 to 86)	0.1	Deg	-10.0 (14.0)	8.0 (46.4)	✓	✓
P-83	Fan Control	0: Off 1: Run 2: Pulse	1		1	1		✓
P-78	Fan Pulse On	00:00 to 99:00	01:00	mm:ss	05:00	05:00		✓
P-79	Fan Pulse Off	00:00 to 99:00	01:00	mm:ss	30:00	30:00		✓
P-15	Probe 5 Select	0: Defrost 1: Monitor	1		0	0	✓	✓
P-16	Relay 2 Mode	0: Lights 1: Alarm	1		0	0	✓	✓
P-17	Evap. Select	0: Local 1: Rem1 2: Rem2 3: Rem3 4: Trans V 5: Trans mA	1		0	0	✓	✓
P-97	Control Fail Valve Level	0 to 100	0.1	%	0.0	0.0	✓	✓
P-29	Probe 1 Resistor Function	0: Plant fault 3 N/O 1: Plant fault 3 N/C 2: Ext Defrost	1		0	0	✓	✓
P-18	Service Time	0 to 128	1	KHrs	60	60	✓	✓
P-19	Switch Resistors	0: Off 1: On	1		1	1	✓	✓
P-98	Lights Case Off	0: Off 1: On 2: Unused	1		0	0	✓	
P-77	Man Stop Valve/Fans	0: Off 1: On	1		0	0		✓
P-100	Digital Input 1 Mode	Types 3 & 4; 0: Plant 1/2 N/O 1: Plant 1/2 N/C 2: Case Switch 3: Temp Switch 4: Defrost 5: Shut Input	1		Types 3 & 4: 0 Types 5 & 6: 5		✓	✓
P-101	Digital Input 2 Mode	Types 5 & 6; 0: Plant 1/2 N/O 1: Plant 1/2 N/C 2: Case Switch 3: Temp Switch 4: Defrost 5: Shut Input 6: Door 7: Man Trap	1		Types 3 & 4: 2 Types 5 & 6: 6		✓	✓
P-102	Cut In Offset	-30 to 30	0.1	Deg	5.0	5.0	✓	✓
P-20	Alarm Delay	00:00 to 99:00	01:00	mm:ss	20:00	20:00	✓	✓
P-21	UT Alarm	-49 to 60 (-56.2 to 140)	0.1	Deg	-30.0 (-22.0)	-2.0 (28.4)	✓	✓
P-22	OT Alarm	-49 to 60 (-56.2 to 140)	0.1	Deg	-15.0 (5.0)	5.0 (41.0)	✓	✓
P-23	Log Probe Type	0: Off 1: Logging 2: Logging/ Alarm	1		0	0	✓	✓
P-24	Slug Log Probe	0: Off 1: On	1		0	0	✓	✓



Please ensure all power is switched off before installing or maintaining this product.

P-25	Log Alarm Delay	00:00 to 99:00	01:00	mm:ss	20:00	20:00	✓	✓
P-26	Log UT Alarm	-49 to 60 (-56.2 to 140)	0.1	Deg	-35.0 (-31)	-1.0 (30.2)	✓	✓
P-27	Log OT Alarm	-49 to 60 (-56.2 to 140)	0.1	Deg	-12.0 (10.4)	6.0 (42.8)	✓	✓
P-28	Monitor OT Alarm	-49 to 60 (-56.2 to 140)	0.1	Deg	20.0 (68)	20.0 (68)	✓	✓
P-58	Probe 2 Alarm	0: Off 1: On	1		1	1	✓	✓
P-40	Defrost Mode	0: Local 1: Remote 2: External	1		Local	Local	✓	✓
P-41	Defrost Start	00:00 to 23:59	00:01	hh:mm	01:00	01:00	✓	✓
P-42	Defrosts per Day	0 to 8	1		6	6	✓	✓
P-43	No Defrost Time	0 to 25	1	Hours	12	12	✓	✓
P-44	Def Terminate Temp.	-42 to 30 (-43.6 to 86)	0.1	Deg	14.0 (57.2)	10.0 (50)	✓	✓
P-45	Def Min Time	00:00 to 99:00	01:00	mm:ss	05:00	05:00	✓	✓
P-46	Def Max Time	00:00 to 99:00	01:00	mm:ss	24:00	24:00	✓	✓
P-47	Drain Down	00:00 to 24:00	00:15	mm:ss	01:30	01:30	✓	✓
P-48	Recovery Time	00:00 to 99:00	01:00	mm:ss	30:00	30:00	✓	✓
P-89	Pump Down Time	00:00 to 99:00	01:00	mm:ss	00:00	00:00	✓	✓
P-86	Fan Delay mode	0: Time 1: Temp	1		0	0	✓	✓
P-49	Fan Delay Time (Cabinets)	00:00 to 99:00	01:00	mm:ss	00:00	00:00	✓	
P-41	Fan Delay Time (Coldroom)	00:00 to 99:00	01:00	mm:ss	03:00	03:00		✓
P-88	Fan Delay Temp	-42 to 30 (-43.6 to 86)	0.1	Deg	-20.0 (-4)	0.0 (32)	✓	✓
P-50	Fans In Defrost	0: Off 1: On	1		Types 3 & 4: 1 Types 5 & 6: 0		✓	✓
P-91	Defrost Type	0: Electric 1: Gas	1		0	0	✓	✓
P-94	Defrost Hold	0: Off 1: On	1		0	0	✓	✓
P-95	Defrost Skip	0: Off 1: On	1		0	0	✓	✓
P-96	Defrost Skip Time	00:00 to 99:00	01:00	mm:ss	12:00	12:00	✓	✓
P-120	Disp Def Button	0: Off 1: On	1		1	1	✓	✓
P-80	Door Alarm Delay	00:00 to 99:00	01:00	mm:ss	20:00	20:00		✓
P-81	Door Closes Valve	0: No 1: Yes	1		0	0		✓
P-82	Door Stops Fan	0: No 1: Yes	1		0	0		✓
P-60	Lights Mode	0: Local 1: Remote 2: Man Off 3: Man On	1		Local	Local	✓	✓
P-61	Sun Lights On	00:00 to 23:59	00:01	hh:mm	08:00	08:00	✓	✓
P-62	Sun Lights Off	00:00 to 23:59	00:01	hh:mm	20:00	20:00	✓	✓
P-63	Mon Lights On	00:00 to 23:59	00:01	hh:mm	08:00	08:00	✓	✓
P-64	Mon Lights Off	00:00 to 23:59	00:01	hh:mm	20:00	20:00	✓	✓
P-65	Tue Lights On	00:00 to 23:59	00:01	hh:mm	08:00	08:00	✓	✓
P-66	Tue Lights Off	00:00 to 23:59	00:01	hh:mm	20:00	20:00	✓	✓
P-67	Wed Lights On	00:00 to 23:59	00:01	hh:mm	08:00	08:00	✓	✓
P-68	Wed Lights Off	00:00 to 23:59	00:01	hh:mm	20:00	20:00	✓	✓
P-69	Thu Lights On	00:00 to 23:59	00:01	hh:mm	08:00	08:00	✓	✓
P-70	Thu Lights Off	00:00 to 23:59	00:01	hh:mm	20:00	20:00	✓	✓
P-71	Fri Lights On	00:00 to 23:59	00:01	hh:mm	08:00	08:00	✓	✓
P-72	Fri Lights Off	00:00 to 23:59	00:01	hh:mm	20:00	20:00	✓	✓
P-73	Sat Lights On	00:00 to 23:59	00:01	hh:mm	08:00	08:00	✓	✓
P-74	Sat Lights Off	00:00 to 23:59	00:01	hh:mm	20:00	20:00	✓	✓
P-30	Broadcast ID	0 to 999	1		0	0	✓	✓



Please ensure all power is switched off before installing or maintaining this product.

P-31	Refrigerant	0 to 27 See Refrigerant Table	1		0	0	✓	✓
P110	Ref weight	0 to 100%	1	%	0	0	✓	✓
P-32	Pressure Units	0: Absolute 1: Gauge	1		1	1	✓	✓
P-33	Evap Offset**	0.0 to 5.0 (0 to 72)	0.1	Bar/psi	0.0	0.0	✓	✓
P-34	Glide	0.0 to 10.0	0.1	Deg	0.0	0.0	✓	✓
P-35	Trans Span***	-3.4 to 180.0	0.1	Bar/psi	13.8	13.8	✓	✓
P-36	Trans Offset***	-3.4 to 180.0	0.1	Bar/psi	0.0	0.0	✓	✓
P-37	MOP Cut-in	-3.4 to 180.0	0.1	Bar/psi	3.4	3.4	✓	✓
P-38	MOP Diff	-3.4 to 180.0	0.1	Bar/psi	0.3	0.3	✓	✓
P-39	MOP Delay	00:00 to 02:00	00:01	mm:ss	00:05	00:05	✓	✓
P-150	Custom A1	-999 to 999	1		0	0	✓	✓
P-151	Custom B1 Hi	-999 to 999	1		-220	-220	✓	✓
P-152	Custom B1 Lo	0 to 999	1		384	384	✓	✓
P-153	Custom C1	-999.9 to 999.9	0.1		262.5	262.5	✓	✓
P-154	Custom A2	-999 to 999	1		0	0	✓	✓
P-155	Custom B2 Hi	-999 to 999	1		-220	-220	✓	✓
P-156	Custom B2 Lo	0 to 999	1		384	384	✓	✓
P-157	Custom C2	-999.9 to 999.9	0.1		262.5	262.5	✓	✓
P-120	Valve Type	0: Carel 1: Sporlan1 2: Sporlan2 3: Alco 4: Other*	1		0	0	✓	✓
P-121	Step Max	0 to 6800 See: Valve type	1		2500	2500	✓	✓
P-122	Step Close	0 to 6800 See: Valve type	1		3500	3500	✓	✓
P-123	Step Speed	0 to 6800 See: Valve type	1	Hz	200	200	✓	✓
P-124	mA Peak	0 to 500 See: Valve Type	1	mA	50	80	✓	✓
P-125	Half Step	0: Off 1: On See: Valve Type	1		0	0	✓	✓
P-126	mA Hold	0 to 500	1		0	0	✓	✓
P-127	Shut Speed	0 to 6800	1	Hz	200	200	✓	✓
P-128	Overdrive Time	1 to 25	1	hours	24	24	✓	✓
P-129	Shut Enable	0: Off 1: N/C 2: N/O	1		0	0	✓	✓
P-130	Shut Time	00:00 to 99:00	01:00	mm:ss	04:00	04:00	✓	✓
dFLt	Restore defaults						✓	✓
ESC	Exits Menu						✓	✓

* Transducer Span and Offset allows for the full range of the transducer to be used by the Mercury Controller. 'Span' is the full range of the transducer, 'Offset' is the value below zero.

Example: RDM PR0160 with range -1 bar to 20 bar, Span would be 21 bar, Offset would be -1 bar.

Refrigerant Table for P-31

No.	Gas	No.	Gas	No.	Gas	No.	Gas	No.	Gas
0	None	6	R401A	12	R407A	18	R507	24	R449A
1	Custom	7	R401B	13	R407B	19	R717	25	R513A
2	R32	8	R401C	14	R407C	20	R290	26	R454C
3	R134a	9	R402A	15	R500	21	R744	27	R455A
4	R142B	10	R402B	16	R502	22	R407F		
5	R227	11	R404A	17	R503	23	R410A		



Please ensure all power is switched off before installing or maintaining this product.

Parameter Tables – 240v Variant

Not all parameters apply to all controller types. For example P-80 is the Door Alarm Delay which only applies to the types 5 & 6. This parameter will not appear if the controller is set to types 3 or 4 (Case controller). In the following table, the type columns on the right hand side will be greyed out if that parameter does not apply to that controller type.

Number	Parameter	Range °C (°F)	Step	Units	Default LT °C (°F)	Default HT °C (°F)	Type 3 & 4	Type 5 & 6
P-01	Cut-in Temp.	-42 to 30 (-43.6 to 86)	0.1	Deg	-20.0 (-4)	0.0 (32)	✓	✓
P-02	Diff.	0 to 10 (0 to 18)	0.1	Deg	2.0 (3.6)	2.0 (3.6)	✓	✓
P-03	Control Weight	0 to 100	1	%	50	50	✓	✓
P-04	Display Weight	0 to 100	1	%	50	50	✓	✓
P-08	Superheat Ref	4 to 12 (7.2 to 21.6)	0.1	Deg	6 (10.8)	6 (10.8)	✓	✓
P-09	Response On	1 to 30	1		10	10	✓	✓
P-10	Response Off	1 to 30	1		10	10	✓	✓
P-11	Control Type	0: EEV 1: EET 2: EEV/EET	1		0	0	✓	✓
P-51	EEV Min Opening	0 to 100	1	%	10	10	✓	✓
P-52	Superheat Problem	0 to 12 (0 to 21.6)	0.1	Deg	0.0	0.0	✓	✓
P-53	Superheat EEV Problem Opening	0 to 100	1	%	10	10	✓	✓
P-54	Superheat EEV Problem Time	00:00 to 99:00	01:00	mm:ss	03:00	03:00	✓	✓
P-56	EEV Start Opening	0 to 100	1	%	50	50	✓	✓
P-55	Ave Valve Opening	0 to 100	1	%	100	100	✓	✓
P-57	EEV Divide Value	0 to 100	1	%	50	50	✓	✓
P-12	Relay 3 Mode (Case)	0: Suction Line 1: Trim Heater 2: Alarm 3: Remote 4: Trim Hub 5: LLV	1		0	0	✓	
	Relay 3 Mode (Coldroom)	0: Suction Line 1: Alarm, 2: Remote 3: LLV	1		0	0		✓
P-13	Trim in Defrost	0: Off 1: On	1		0	0	✓	
P-14	Trim Level	0 to 100	1	%	100	100	✓	
P-85	Key-switch Mode	0: Case Off 1: Fans only 2: toggle 3: Key Off	1		3	3	✓	✓
P-87	Control Probe type	0: Use Air on Probe 1: Use Log Probe	1		0	0	✓	✓
P-90	Resistor Case Off	0: Disabled 1: Enabled	1		0	0	✓	✓
P-92	Fans temperature mode	0: Off 1: Temperature 2: Over-temperature 3: Temp/ OT	1		0	0	✓	✓
P-93	Fans Off Temperature	-42 to 30 (-43.6 to 86)	0.1	Deg	-10.0 (14.0)	8.0 (46.4)	✓	✓
P-83	Fan Control	0: Off 1: Run 2: Pulse	1		1	1		✓
P-78	Fan Pulse On	00:00 to 99:00	01:00	mm:ss	05:00	05:00		✓
P-79	Fan Pulse Off	00:00 to 99:00	01:00	mm:ss	30:00	30:00		✓
P-15	Probe 5 Select	0: Defrost 1: Monitor	1		0	0	✓	✓



Please ensure all power is switched off before installing or maintaining this product.

P-16	Relay 2 Mode	0: Lights 1: Alarm	1		0	0	✓	✓
P-17	Evap. Select	0: Local 1: Rem1 2: Rem2 3: Rem3 4: Trans V 5: Trans mA	1		0	0	✓	✓
P-97	Control Fail Valve Level	0 to 100	0.1	%	0.0	0.0	✓	✓
P-29	Probe 1 Resistor Function	0: Plant fault 3 N/O 1: Plant fault 3 N/C 2: Ext Defrost	1		0	0	✓	✓
P-18	Service Time	0 to 128	1	KHrs	60	60	✓	✓
P-19	Switch Resistors	0: Off 1: On	1		1	1	✓	✓
P-98	Lights Case Off	0: Off 1: On 2: Unused	1		2	2	✓	
P-77	Man Stop Valve/Fans	0: Off 1: On	1		0	0		✓
P-20	Alarm Delay	00:00 to 99:00	01:00	mm:ss	20:00	20:00	✓	✓
P-21	UT Alarm	-49 to 60 (-56.2 to 140)	0.1	Deg	-30.0 (-22.0)	-2.0 (28.4)	✓	✓
P-22	OT Alarm	-49 to 60 (-56.2 to 140)	0.1	Deg	-15.0 (5.0)	5.0 (41.0)	✓	✓
P-23	Log Probe Type	0: Off 1: Logging 2: Logging/ Alarm	1		0	0	✓	✓
P-24	Slug Log Probe	0: Off 1: On	1		0	0	✓	✓
P-25	Log Alarm Delay	00:00 to 99:00	01:00	mm:ss	20:00	20:00	✓	✓
P-26	Log UT Alarm	-49 to 60 (-56.2 to 140)	0.1	Deg	-35.0 (-31)	-1.0 (30.2)	✓	✓
P-27	Log OT Alarm	-49 to 60 (-56.2 to 140)	0.1	Deg	-12.0 (10.4)	6.0 (42.8)	✓	✓
P-28	Monitor OT Alarm	-49 to 60 (-56.2 to 140)	0.1	Deg	20.0 (68)	20.0 (68)	✓	✓
P-40	Defrost Mode	0: Local 1: Remote 2: External	1		Local	Local	✓	✓
P-41	Defrost Start	00:00 to 23:59	00:01	hh:mm	01:00	01:00	✓	✓
P-42	Defrosts per Day	0 to 8	1		6	6	✓	✓
P-43	No Defrost Time	0 to 25	1	Hours	12	12	✓	✓
P-44	Def Terminate Temp.	-42 to 30 (-43.6 to 86)	0.1	Deg	0.0 (32.0)	0.0 (32.0)	✓	✓
P-45	Def Min Time	00:00 to 99:00	01:00	mm:ss	05:00	05:00	✓	✓
P-46	Def Max Time	00:00 to 99:00	01:00	mm:ss	24:00	24:00	✓	✓
P-47	Drain Down	00:00 to 24:00	00:15	mm:ss	01:30	01:30	✓	✓
P-48	Recovery Time	00:00 to 99:00	01:00	mm:ss	30:00	30:00	✓	✓
P-89	Pump Down Time	00:00 to 99:00	01:00	mm:ss	00:00	00:00	✓	✓
P-86	Fan Delay mode	0: Time 1: Temp	1		0	0	✓	✓
P-49	Fan Delay Time (Cabinets)	00:00 to 99:00	01:00	mm:ss	00:00	00:00	✓	
	Fan Delay Time (Coldroom)	00:00 to 99:00	01:00	mm:ss	03:00	03:00		✓
P-88	Fan Delay Temp	-42 to 30 (-43.6 to 86)	0.1	Deg	-20.0 (-4)	0.0 (32)	✓	✓
P-50	Fans In Defrost	0: Off 1: On	1		Types 3 & 4: 1 Types 5 & 6: 0		✓	✓
P-94	Defrost Hold	0: Off 1: On	1		0	0	✓	✓
P-95	Defrost Skip	0: Off 1: On	1		0	0	✓	✓
P-96	Defrost Skip Time	00:00 to 99:00	01:00	mm:ss	12:00	12:00	✓	✓



Please ensure all power is switched off before installing or maintaining this product.

P-80	Door Alarm Delay	00:00 to 99:00	01:00	mm:ss	00:00	00:00		✓
P-81	Door Closes Valve	0: No 1: Yes	1		0	0		✓
P-82	Door Stops Fan	0: No 1: Yes	1		0	0		✓
P-60	Lights Mode	0: Local 1: Remote 2: Man Off 3: Man On	1		Local	Local	✓	✓
P-61	Sun Lights On	00:00 to 23:59	00:01	hh:mm	08:00	08:00	✓	✓
P-62	Sun Lights Off	00:00 to 23:59	00:01	hh:mm	20:00	20:00	✓	✓
P-63	Mon Lights On	00:00 to 23:59	00:01	hh:mm	08:00	08:00	✓	✓
P-64	Mon Lights Off	00:00 to 23:59	00:01	hh:mm	20:00	20:00	✓	✓
P-65	Tue Lights On	00:00 to 23:59	00:01	hh:mm	08:00	08:00	✓	✓
P-66	Tue Lights Off	00:00 to 23:59	00:01	hh:mm	20:00	20:00	✓	✓
P-67	Wed Lights On	00:00 to 23:59	00:01	hh:mm	08:00	08:00	✓	✓
P-68	Wed Lights Off	00:00 to 23:59	00:01	hh:mm	20:00	20:00	✓	✓
P-69	Thu Lights On	00:00 to 23:59	00:01	hh:mm	08:00	08:00	✓	✓
P-70	Thu Lights Off	00:00 to 23:59	00:01	hh:mm	20:00	20:00	✓	✓
P-71	Fri Lights On	00:00 to 23:59	00:01	hh:mm	08:00	08:00	✓	✓
P-72	Fri Lights Off	00:00 to 23:59	00:01	hh:mm	20:00	20:00	✓	✓
P-73	Sat Lights On	00:00 to 23:59	00:01	hh:mm	08:00	08:00	✓	✓
P-74	Sat Lights Off	00:00 to 23:59	00:01	hh:mm	20:00	20:00	✓	✓
P-58	Broadcast ID	0 to 999	1		0	0	✓	✓
P-59	Refrigerant	0 to 25 See Refrigerant Table	1		0	0	✓	✓
P-39	Ref weight	0 to 100%	1	%	0	0	✓	✓
P-75	Pressure Units	0: Absolute 1: Gauge	1		1	1	✓	✓
P-76	Evap Offset**	0.0 to 5.0 (0 to 72)	0.1	Bar/psi	0.0	0.0	✓	✓
P-84	Glide	0.0 to 10.0	0.1	Deg	0.0	0.0	✓	✓
P-91	Trans Span***	-3.4 to 180.0	0.1	Bar/psi	13.8	13.8	✓	✓
P-99	Trans Offset***	-3.4 to 180.0	0.1	Bar/psi	0.0	0.0	✓	✓
P100	MOP Cut-in	-3.4 to 180.0	0.1	Bar/psi	3.4	3.4	✓	✓
P101	MOP Diff	-3.4 to 180.0	0.1	Bar/psi	0.3	0.3	✓	✓
P102	MOP Delay	00:00 to 02:00	00:01	mm:ss	00:05	00:05	✓	✓
P-30	Valve Type	0: Carel 1: Sporlan1 2: Sporlan2 3: Alco 4: Other*	1		0	0	✓	✓
P-31	Step Max	0 to 6800 See: Valve type	1		2500	2500	✓	✓
P-32	Step Close	0 to 6800 See: Valve type	1		3500	3500	✓	✓
P-33	Step Speed	0 to 6800 See: Valve type	1	Hz	200	200	✓	✓
P-34	mA Peak	0 to 500 See: Valve Type	1	mA	50	80	✓	✓
P-35	Half Step	0: Off 1: On See: Valve Type	1		0	0	✓	✓
P-36	mA Hold	0 to 500	1		0	0	✓	✓
P-37	Shut Speed	0 to 6800	1	Hz	200	200	✓	✓
P-38	Overdrive Time	1 to 25	1	hours	24	24	✓	✓
P-06	Shut Enable	0: Off 1: N/C 2: N/O	1		0	0	✓	✓
P-07	Shut Time	00:00 to 99:00	01:00	mm:ss	04:00	04:00	✓	✓
P-38	Door Switch	0: Off 1: N/O 2: N/C	1		0	0		✓
P103	Div Size	0: Off 1: On	1		0	0	✓	✓
dFLt	Restore defaults						✓	✓
ESC	Exits Menu						✓	✓



Please ensure all power is switched off before installing or maintaining this product.

Refrigerant Table for P-59

No.	Gas	No.	Gas	No.	Gas	No.	Gas	No.	Gas
0	None	6	R401A	12	R407A	18	R507	24	R449A
1	Custom	7	R401B	13	R407B	19	R717	25	R513A
2	R32	8	R401C	14	R407C	20	R290		
3	R134a	9	R402A	15	R500	21	R744		
4	R142B	10	R402B	16	R502	22	R407F		
5	R227	11	R404A	17	R503	23	R410A		

Parameter Descriptions

Number	Parameter	Description
P-01	Cut-in Temp	Temperature at which the valve will switch on.
P-02	Diff	Differential temperature below the cut-in temperature. The valve switches off when below this temperature.
P-03	Control Weight	Percentage of the Air-On temperature that is used to calculate the control temp. The remaining percentage will be used on the Air-Off temperature Example, P-03 set to 30% Control temp = 30% Air-on + 70% Air-off
P-04	Display Weight	As above only applied to the display temperature.
P-05*	Alarm Weight	Percentage of the Air-On temperature that is used to calculate the over temperature alarm.
P-08	Superheat Ref	The controller will attempt to maintain this superheat value
P-09	Response on	Allows the user to adjust the valve opening rate in relation to superheat change, with 30 providing the quickest response and 1 providing the slowest response.
P-10	Response off	Allows the user to adjust the valve closing rate in relation to superheat change, with 30 providing the quickest response and 1 providing the slowest response.
P-11	Control Type	Allows the user to select either; EEV control, EET control or EEV/EET control. Note the Evaporator Temperature probe should be fitted to the coldest point in the evaporator. EEV: Uses the superheat as its main reference with the cabinet temperature as a secondary control. EET: Use the cabinet temperature as its main reference with the superheat as a secondary control. EEV/EET: Uses cabinet temperature as the main control until the SH gets close to the SH reference point, then it switches to EEV control, it switches back to EET control when the SH reference is satisfied.
P-51	EEV Minimum Opening	Sets the minimum valve opening level, during normal operation the valve will not go below this level. (Default 10%). If using a pressure transducer as opposed to temperature probes only, then the Minimum value opening should be set at 0%
P-52	Superheat Problem	Sets the point at which the controller will go to the 'EEV Problem' state due to the superheat value. For example if this parameter is set to 0 Degrees and the Superheat value falls to 0 degrees or below, for the duration of P-54, then the controller will enter the superheat problem state which will force the valve opening to the value set in P-53.
P-53	Superheat EEV Problem Opening	Sets the valve open position when entering the 'Superheat EEV Problem' state.
P-54	Superheat EEV Problem Time	Sets the time the controller stays in the 'Superheat EEV Problem' state.
P-56	EEV Start Opening	Sets the valve opening % which is used after a defrost or when the controller exits a problem state for, example Superheat EEV Problem state
P-55	Average Valve Opening	Normally the valve during recovery will open to the last average position. This setting allows for that value to be reduced by said percentage. For example if the average valve opening is calculated as 80% and P-55 is set to 50% then the valve will open at 40%.
P-57	EEV Divide value	This parameter takes effect when the controller is used in conjunction with a pressure transducer. When an MOP (maximum operating pressure) alarm is generated the controller reduces the maximum valve opening to this percentage. For example if this parameter is set to 50% and the MOP alarm is generated then the maximum valve opening will be limited to 50%. When P-103 (if present) is set to 'on' then the divide value will be used all the time regardless of MOP).



Please ensure all power is switched off before installing or maintaining this product.

		Note P-51 EEV Minimum opening overrides the valve output operation and the valve will not open below this setting. Please see Maximum Operating Pressure (MOP) note. Please note parameters P-51 through to P-57 should not be altered without first understanding the effects they may have on the case operation. If incorrectly set they may have undesired affects.
P-12	Relay 3 Mode	Relay 3 can be a Suction, Trim Heater, Alarm, Remote, Trim Hub relay or Liquid Line Valve (LLV) <ul style="list-style-type: none"> Suction – set for Suction Line Valve operation. Trim Heater – set as trim relay which pulses in accordance with P-14 or the Data Manager energy feature trim control. Alarm – The alarm relay is energised for no alarm. Use the NC and Common for 'Loop make' on alarm or use the NO and Common for 'Loop break' on alarm. Remote – The relay is available for remote purposes such as the Data Manager GP timer channel or Data Builder software. Trim Hub – Relay is pulsed in accordance with the Trim Control feature present in the Mercury Switch (PR0018-PHI). Please see the Mercury switch user document for further details. LLV – The relay operates a liquid line valve which is open when the stepper valve is operating and closed when the stepper valve is at 0% (during defrost for example)
P-13	Trim in Defrost	Allows the trims to be off or on during a defrost.
P-14	Trim Level	Sets a percentage level, of a 5-minute period, to pulse the trim heater relay off/on. Example: - P-14 set to 50% = 2.5 minutes on, 2.5 minutes off. If the controller is networked to a Data Manager operating the energy feature Trim Control then the Data Manager feature will override this parameter setting. Please refer to the Data Manager user document for further details. Note the trims are turned off when an over temperature alarm occurs.
P-85	Key-switch Mode	Allows the keys switch to be: <ul style="list-style-type: none"> Single turn for case off (Case off mode) Single turn for Fans only (Fans Mode) Single turn for case off, double turn for fans only (Toggle mode) Not used (Key Off)
P-87	Control Probe type	Switches between using the air-on probe and the Logging probe. Note the control and display temperature will still be a derivative of the weighted Average of the control probe + Air-off probe
P-90	Resistor Case Off	Turns on/off the switched resistor case off function
P-92	Fans temperature mode	Allows the user to set the fans to turn off when: - <ul style="list-style-type: none"> A pre-determined temperature is reached (P93) When an over-temperature alarm is present When either P93 is reached or an OT alarm is present
P-93	Fans Off Temperature	Temperature for the above (P92) operation. Note the defrost termination probe is the source of the temperature reading used in this feature. If the defrost termination probe isn't fitted then a similar process to P-44 is used.
P-83	Fan Control	This feature allows for coldroom fans to be stopped when the coldroom is down to temperature thus saving energy. <ul style="list-style-type: none"> Off – When the valve closes the fans stay on for the Fan Pulse On (P-78) time before going off until the LLV next operates. Run – fans operate as per the normal control strategy. Pulse – When the valve closes the fans will stop when the Fan Pulse On parameter (P-78) time expires. The fans then remain off for the Fan Pulse Off time (P-79). When the parameter Fan Pulse Off time expires the fans come back on for the Fan Pulse on time. The cycle then repeats. The fans resume normal operation if the valve operates. The fans pulse on/off to ensure the circulation of air within the coldroom. Placement of the temperature control probes is important when using this feature
P-78	Fan Pulse On	The duration of the fans are pulsed on in Fan Control.
P-79	Fan Pulse Off	The duration of the fans are pulsed off in Fan Control.
P-15	Probe 5 Select	This input can be used as a defrost termination probe (default) or as a monitor probe with an OT alarm level.
P-16	Relay 2 mode	This changes the function of relay 3 from Lights (default) to an alarm relay. The alarm relay is energised for no alarm. Use the NC and Common for 'Loop make' on alarm or use the NO and Common for 'Loop break' on alarm.
P-17	Evap. Select	This allows the control algorithm to use a remote pressure input converted to temperature in place of the evaporator in value. In the event of no remote value being received, the control algorithm will revert to using the evaporator in probe value until the remote value is restored.



Please ensure all power is switched off before installing or maintaining this product.

		Please see : Valve Control Using Pressure
P-97	Control Fail Valve Value	This value is used in the event of a control probe fail; In the control algorithm the valve will remain at this opening until the probe fault has been cleared. Please note the incorrect setting of this value may result in flood back causing damage to the pack compressors. Do not adjust this parameter if you are unsure of the consequences.
P-29	Probe 1 Resistor Function	Selects whether the switched resistor invokes either a Plant fault or an External Defrost.
P-18	Service Interval Time (Run Hours)	Time (in 1000 x hours) before the service icon (Spanner icon) comes on. The Run Hours timer increments based on the number of hours the controller has been powered up and running. Reset the spanner icon to off by changing this parameter to 0 and then back to the desired service interval. This process also resets the Run Hours value to 0. To view the current Run Time value refer to the I/O list.
P-19	Switch Resistors	Enables switched resistors to be used for Plant Faults, External Defrosts, Case Clean, Man Trap, Door Switch See : Switched Resistor Values
P-98	Lights Case Off	Used to place the controller into Case Off when its lighting timer is in the off state. When the lighting timer is in the on state the controller follows its normal control operation. This feature is disabled if the set point (P-01) is below 6°C. Please note that when the controller is in case off all alarms are inhibited and all outputs are turned off. Therefore care must be taken when enabling this parameter. <ul style="list-style-type: none"> Off – Feature is not used and only the controller lights relay follows the lighting timer status. On – Feature is in use and controller will be in Case Off whenever the lights timer is in the off state. Unused - This selection has no effect and should not be used. Please select from either Off or On. This feature operates in either Local, using controller RTC, or Remote, using Data Manager GP timer channel, lighting applications.
P-77	Man Stop Valve/Fans	When man trap input is activated the valve closes and fans are stopped. Normal operation resumes when the mantrap input is deactivated.
P-100* P-101*	Digital 1 Mode Digital 2 Mode	Sets the status input type for the two Digital Inputs (24v Version Only) <ul style="list-style-type: none"> ➤ Plant 1/2 – When the DI is activated, it would alarm Plant Fault 1/2 (N/O or N/C) ➤ Case Switch – Would carry out the operation set on the 'Key Switch mode' (p-85) ➤ Temp Switch – Adds temperature setpoint offset value set in P-102 ➤ Defrost – The DI activation would signal the unit to go into a defrost (must be set to remote df). ➤ Shut Input – Used in conjunction with the Intuitive power store (PR0627), closes the valve in the event of a power fail. ➤ Door – The DI activation would signal if the door is open or closed. ➤ Person Trap – If the DI signal is received, a Person Trap alarm is activated.
P-102*	Cut-In offset	The value added to the Cut-In Setpoint, OT and UT alarm thresholds when a temperature offset is applied. This can be done from a digital input set to 'Temp Switch' or via a Data Manager TDB command.
P-20	Alarm Delay	Delay for the over and under-temperature alarms
P-21	UT Alarm	Under temperature alarm set point. This alarm uses the control temperature.
P-22	OT Alarm	Over temperature alarm set point. This alarm uses the air-off temperature.
P-23	Log Probe Type	Allows the user to set the logging probe mode: <ul style="list-style-type: none"> • Off • Logging with no alarms • Logging with alarms
P-24	Slug Log Probe	Applies a damping factor. This can be used to make a standard probe have the same temperature response as a logging probe.
P-25	Log Alarm Delay	Delay for the Logging probe over and under-temperature alarms
P-26	Log UT Alarm	Logging probe under temperature alarm set point
P-27	Log OT Alarm	Logging probe over temperature alarm set point
P-28	Monitor OT Alarm	Monitor probe over temperature alarm set point
P-58*	Probe 2 Alarm	Allows user to disable Probe 2 alarms if probe is not fitted.
P-40	Defrost Mode	Allows the user to set the defrost mode: - <ul style="list-style-type: none"> ➤ Local (Uses the internal parameters P-41 and P-42) ➤ Remote (Requires a defrost schedule in the front end) ➤ External (uses a switched resistor in input 1). When this signal is present a defrost is initiated.



Please ensure all power is switched off before installing or maintaining this product.

		Note: - If the external defrost signal is not removed then the controller will defrost according to the 'No Defrost' time and a missed defrost alarm will be generated. See P-29 for external defrost signal setup.
P-41	Defrost Start	When defrost mode is set to 'Local', this is the start time for the 1 st defrost
P-42	Defrosts per Day	When defrost mode is set to 'Local', this is the number of defrosts per day equally spaced from the start time.
P-43	No Defrost Time	If the controller misses a defrost command for any reason, a defrost will initiate after this time has elapsed from the last defrost. Normally set to 2 hours over the normal defrost period.
P-44	Def Terminate	The defrost will terminate (defrost control relay off) when the temperature of the defrost termination probe reaches this value. If the 'defrost termination' probe is not fitted, defrost termination will occur when: The 'coil in' probe reaches the set point (If fans are selected as 'off during defrost') Or The 'air off' probe reaches the set point (If fans are selected as 'on during defrost'). If the 'coil in' probe is not fitted, the 'air off' probe will be used.
P-45	Def Min Time	Minimum time that a defrost will use (Defrost can't terminate until this time has elapsed. If termination temperature is reached during this period, the defrost control relay is turned off, but the controller will not continue the defrost cycle until the end of the defrost min period)
P-46	Def Max Time	Time period after defrost minimum that defrosts are allowed to terminate
P-47	Drain Down	A period after defrost max to allow the draining of any surplus water
P-48	Recovery Time	The valve is opened at the start of this period to allow the temperature to recover to the normal operating point. This period also inhibits the OT alarm. Note that if the air-off temperature is still above the OT alarm setpoint when this period expires, an immediate OT alarm occurs; there is not a further alarm delay.
P-89	Pump Down Time	Time period before the defrost min period to allow for a pump down
P-86	Fan Delay mode	This parameter allows the fans start after a drain-down period to be delayed, either by time (P-49) or when the temperature point (P-88) is reached. This parameter uses the same probe strategy as the defrost terminate.
P-49	Fan Delay	Time after a drain-down period before the fans start if P-86 is set to time
P-88	Fan Delay Temp	Temperature at which the fans start after a drain-down period when P-86 is set to temperature.
P-50	Fans In Defrost	Allows the user to set the fans on or off in defrost. Note if the fans are set to on in defrost, they will go off for the drain-down period and then follow the P-86 rules.
P-94	Defrost Hold	Turns the defrost hold feature on and off. When switched on, the controller can be held in defrost until a remote command from the front end starts the recovery process.
P-95	Defrost Skip	Allows user to enable/disable defrost skip. This feature allows the controller to skip defrosts. If the current defrost terminates on temperature then the controller will skip the next scheduled defrost providing the previous defrost terminated before the defrost skip time (P-96). Operates only when the controller is set to local defrost scheduling.
P-96	Defrost Skip Time	Time factor used in defrost skip. The previous defrost has to terminate before this value expires to allow the controller to skip a defrost.
P-120*	Disp Def Button	Allows to option to turn off the local defrost button (#) on the controller display.
P-80	Door alarm delay	Delay after the door open input is activated before the alarm occurs.
P-81	Door Closes Valve	This parameter is used to close the stepper valve if the door opens. If the door remains open then the valve will resume normal operation on the expiry of the door alarm delay (P-80).
P-82	Door Stops Fan	This parameter is used to stop the fans if the door opens. If the door remains open then the fans will resume normal operation on the expiry of the door alarm delay (P-80).
P-60	Lights Mode	Allows the user to set the lights mode: <ul style="list-style-type: none"> • Use a local schedule P-61 to P-74) • Use a remote schedule (Set up in the system front end) • Always off • Always on
P-61	Sun Lights On	When P-60 is set to Local, Sunday on time
P-62	Sun Lights Off	When P-60 is set to Local, Sunday off time
P-63	Mon Lights On	When P-60 is set to Local, Monday on time
P-64	Mon Lights Off	When P-60 is set to Local, Monday off time
P-65	Tue Lights On	When P-60 is set to Local, Tuesday on time
P-66	Tue Lights Off	When P-60 is set to Local, Tuesday off time



Please ensure all power is switched off before installing or maintaining this product.

P-67	Wed Lights On	When P-60 is set to Local, Wednesday on time
P-68	Wed Lights Off	When P-60 is set to Local, Wednesday off time
P-69	Thu Lights On	When P-60 is set to Local, Thursday on time
P-70	Thu Lights Off	When P-60 is set to Local, Thursday off time
P-71	Fri Lights On	When P-60 is set to Local, Friday on time
P-72	Fri Lights Off	When P-60 is set to Local, Friday off time
P-73	Sat Lights On	When P-60 is set to Local, Saturday on time
P-74	Sat Lights Off	When P-60 is set to Local, Saturday off time
P-30/ P-58	Broadcast ID	ID of Plant Controller being used to broadcast Suction Pressure The Broadcast ID is derived from the Rotary Switch positions set on the Plant controller which is providing the remote suction pressure. Note: No two Plant controllers on a local area network can have the same rotary switches positions set. This will have adverse effects on control.
P-31/ P-59	Refrigerant	Type of refrigerant gas used in the system. See: Refrigerant Table above
P-110/ P-39	Ref weight	When using a local pressure transducer or a transmitted pressure from a pack controller is used to calculate superheat, the Mercury controller can use a weighted average of liquid pressure and vapour pressure to calculate the temperature. When the refrigerant weight parameter is set to 0% then the liquid pressure is used (bubble), when set to 100% the vapour pressure is used (dew). For example, when the Ref Weight parameter is set to 50%, then the controller will use a weighted average of 50% liquid pressure and 50% vapour pressure. Any percentage from 1 to 99% will give an appropriate weighted average between the two pressures.
P-32/ P-75	Pressure Units	Absolute or Gauge
P-33/ P-76	Evap Offset	Offset to allow for pressure drop over distance
P-34/ P84	Glide	Allows a glide value to be applied for a particular refrigerant mix where the component gases have different boiling points (at the same pressure).
P-35/ P-91	Trans Span	Total range of the transducer
P-36/ P-99	Trans Offset	Value below zero
P-37/ P100	MOP Cut-in	If the pressure exceeds this value, then the controller's valve will close or be reduced to a predetermined percentage. A MOP alarm is also created. (See Maximum Operating Pressure (MOP)). If the controller is connected to a Mercury switch (PR0018-PHI) with a pressure transducer connected fitted then the MOP parameters are contained within the switch, MOP parameters in the Mercury controller do not apply.
P-38/ P101	MOP Diff	When the pressure reduces below this value, the controllers valve will recover to their normal operational
P-39/ P102	MOP Delay	Delay after the MOP value has been exceeded before the MOP actions and alarm occurs.
P-150*	Custom A1	For more information regarding the setting up of custom refrigeration, please contact RDM Technical Support.
P-151*	Custom B1 Hi	
P-152*	Custom B1 Lo	
P-153*	Custom C1	
P-154*	Custom A2	
P-155*	Custom B2 Hi	
P-156*	Custom B2 Lo	
P-157*	Custom C2	
P-120/ P-30	Valve Type	Choose from four preconfigured stepper valve types or select 'Other' to enter Stepper characteristics for a valve which is not listed. See Valve Type
P-121/ P-31	Step Max	Number of steps controller will send to open valve to 100%. Consult the valve manufacturer to obtain the required number of steps. (Has no effect if Valve Type 0, 1, 2 or 3 selected at P-120). See Valve Type
P-122/ P-32	Step Close	Number of steps controller will send to close valve fully to 0% and overdrive the valve. The Steps required when overdriving the valve can vary. Please consult the valve manufacturer to obtain the required number of steps (Has no effect if Valve Type 0, 1, 2 or 3 selected at P-120) See Valve Type
P-123 P-33	Step Speed	Increases and decreases the rate of step change. Enter a value in Hz. Valve Manufacturers specification must be followed. (Has no effect if Valve Type 0, 1, 2 or 3 selected at P-120) See Valve Type



Please ensure all power is switched off before installing or maintaining this product.

P-124/ P-34	mA Peak	Current requirement of motor. Care should be taken when setting this parameter as too high a setting could damage the valve motor. Valve Manufacturers specification must be followed. (Has no effect if Valve Type 0, 1, 2 or 3 selected at P-120) See Valve Type
P-125/ P-35	Half Step*	Allows the stepper motor to be rotated in half step increments when used in conjunction with a half step compatible valve. The parameter has no effect if the Valve Type (P-120) is set to 0, 1, 2 or 3 (See Valve type). To allow for half stepping P-120 must be set to '4' (other). *Important: From Software V3.5 by selecting half step, the Step Max and Step Close parameters (P-121 & 122) will automatically be doubled. In versions prior to this these parameters should be set to double the normal values when Half Stepping is enabled. Note: When using a Carel E ² V valve with this controller it is advisable to use half stepping.
P-126/ P-36	mA Hold	Current supplied to valve when it is stationary, to prevent any drift in valve position See: Holding Current
P-127/ P-37	Shut Speed	This is the speed in Hz that the valve will shut at if the shut input (probe 7) becomes open circuit.
P-128/ P-38	Overdrive Time	This is the period in hours that the valve will close fully to allow the controller to re calibrate the valve position, this is required as there is no feedback to the controller from the valve in regards to its position. See: Valve State – Overdriving
P-129/ P-06	Shut Enable	Enables the shut input from the Intuitive Power Store, set to N/C. Will only work if valve type P-120 is set to 'Other'
P-130/ P-07	Shut Time	Once the shut input has been activated the valve will stay closed for this period even if the shut input is removed.
P-38	Door Switch	Sets the door switch input to either; <ul style="list-style-type: none"> • Off • Normally Closed contact • Normally Open contact
P-103	Div Size	When set to On, the EEV maximum opening will be permanently used, set within the EEV Divider Value (P-57).
dFLt	Restore default values	Restores all of the parameters to their default values

Holding Current

If using a type of valve that requires a holding current (P-126 / P-36) 'Other' must be selected as the 'Valve Type' (P-120/ P-30). The subsequent parameters P-121 to P-125 (P-31 to P-35) must then also be set accordingly to the correct values.

Warning: Not all valves require a holding current and applying a holding current to valves that do not require one could result in damage to the valve and/or controller.

Always Refer to Manufacturers Data Sheet for information on holding current.

Half Step

Parameter P-125/ P-35 allows the stepper motor to be rotated in half step increments when used in conjunction with a half step compatible valve. The parameter has no effect if the Valve Type (P-120/ P-30) is set to 0, 1, 2 or 3 (See [Valve type](#)). To allow for half stepping P-120/ P-35 must be set to '4' (other).

Important: From Software V3.5 by selecting half step, the Step Max and Step Close parameters (P-121/ P-31 & P-122/ P-32) will **automatically** be doubled. In versions prior to this these parameters should be set to double the normal values when Half Stepping is enabled.

For example when using a Carel E²V valve, which requires half stepping to be enabled, although it is similar to the E³V Carel valve whereby 'Step speed' and 'mA Peak' match, P-120/ P-30 (valve type) must be set to 'Other' for half stepping to be used. **Note:** When using a Carel E²V valve with this controller it is advisable to use half stepping.

Stepper Valve Type

Parameters P-121 to P-125 (P-31 to P-35) only have an effect if 'Other' is selected when configuring parameter P-120/ P-30. 'Other' allows the user to map in the requirements the stepper valve.



Please ensure all power is switched off before installing or maintaining this product.

Selecting option 0, 1, 2 or 3 at parameter P-120 sets the controller for use with the factory set values for the type of valve selected. The controller will override any values set in parameters P-121, P-122, P-123 and P-125. **Note** the parameters relating to the Stepper Valve type should be configured prior to wiring the Stepper Valve to the Mercury 2 Stepper controller. If one of the three default valve types is selected then changing P-121, P-122, P-123, P-124 and P-125 will have no effect.

Manufacturer	Model	Step Max	Step Close	Step Speed (Hz)*	mA Peak	mA Hold	Half Step	Overdrive (Hrs)
Carel	E ³ V	480	500	50	450	0	Off	8
Sporlan 1	SER A/B/C/D	2500	3500	200	80	0	Off	24
Sporlan 2	SER 1.5 to 20, SEI 6	1596	1756	200	80	0	Off	24
Alco	EX4/5/6	750	825	500	500	0	Off	8
Other	Various	2500	3500	200	80	0	Off	8

See [Appendix 3 Step Speed](#) also.

Valve Wiring

Manufacturer	Model	Wiring (Colours)	Connection Description (See Stepper Output)
Carel	E ³ V / E ² V	Yellow	M1B
		White	M1A
		Green	M2A
		Brown	M2B
Sporlan	SER 1.5 - 20 SER B/C/D SEI 6	Green	M1B
		Red	M1A
		White	M2A
		Black	M2B
Alco	EX4/EX5/EX6	White (A)	M1B
		Black (B)	M1A
		Blue I	M2A
		Brown (D)	M2B

Important: Our information is taken from 3rd party data sheets at the time our document is created, any changes since will not be incorporated in our document. Review the manufacturer's datasheet for the selected valve before installation. If you are unsure regarding any of the above steps please contact RDM Technical Support for further assistance.

Valve State – Overdriving

Each time the controller is powered on the control valve state has to initialise as the controller will have no knowledge of the current valve opening position for the stepper motor attached. During this process the controller will close the valve by a number of steps greater than the total number of steps for the valve configured. This is achieved using the Step Close parameter and is referred to as 'overdriving' the valve. This process will synchronize the controller with the stepper valve output. This ensures the stepper valve is at the 0 steps position, fully closed and the control algorithm will use this for future control operations.

The overdrive parameter (P-128/ P38) will overdrive the Stepper motor output by 10% of the step max value at the pre-set period (24 hours for example), this provides an automatic re-synchronisation of the valve position.

Please consult the stepper valve manufacturer's data sheet to obtain the number of steps required to overdrive the valve.



Please ensure all power is switched off before installing or maintaining this product.

Stepper Valve Control Using Pressure

There are several ways to use the suction pressure to calculate the evaporator in temperature.

Direct Transducer Connection

Evap Select (P-17) set to Trans V or Trans mA.
Parameters P-30 to P-36 (P-58 to P-99) will need to be set accordingly.

A suction transducer can be connected directly to the controller, the controller will calculate the evaporator temperature from the suction pressure, and along with the suction temperature probe local to the controller the superheat is calculated. Please note that RDM recommend that the evaporator in temperature probe is fitted as the controller will use this to calculate the superheat in the event of a transducer fault

Mercury Switch (PR0018-PHI)

Evap Select (P-17) set to Rem1

The Mercury Switch can be used for EEV control on an Island by island basis. A suction pressure transducer is connected from the case Island to the 4-20mA input of the Mercury Switch and the pressure read from this transducer is converted to a temperature based on the gas type being used by the system. This temperature is transmitted to each controller connected to the switch and along with the suction temperature probe, local to the controller, the superheat is calculated. Please note that RDM recommended that the evaporator in temperature probe is fitted as the controller will use this to calculate the superheat in the event of a communication loss with the Mercury Switch. P-17 allows for the use of this remote temperature provided by the Mercury Switch. Please see the Mercury Switch user document (PR0018-PHI) for further details. **Note: RS232 comms variants only**

Remote pressure Direct from a Plant Pack Controller

Evap Select (P-17) set to Rem1/ Rem2/ Rem3
Broadcast ID (P-30/ P-58) set to network ID of Plant Pack
Refrigerant (P-31/ P-59) set accordingly

Evap Select (P-17) is set depending on which input the suction transducer is connected to on the plant controller (Transducer input 1, 2 or 3). The broadcast ID (P-30/ P-58) should be set to the network ID of Plant Pack Controller (Rotary Switch Setting). The Refrigerant type (P-31/ P-59) must be set along with pressure units (P-32/ P-75) set to Absolute or Gauge. This method cannot be used when using a PR0018-PHI Hub.

Maximum Operating Pressure (MOP)

The controller can calculate it's superheat using a pressure value. This pressure value can be obtained in 3 different ways: transmitted from an RDM pack controller, from a pressure transducer fitted to a local Mercury Switch or a pressure transducer connected directly to the controller. If the MOP cut-in value is exceeded then the stepper valve opening is reduced by the 'Div Value' parameter and an MOP alarm generated. For example if the 'Div Value' parameter is set to 50% and the MOP alarm is generated then the maximum valve opening will be limited to 50%.

Ref. Weighting

When using a local pressure transducer to calculate superheat, the Mercury controller can use a weighted average of liquid pressure and vapour pressure to calculate the temperature. For example, when the Ref Weight parameter is set to 50%, then the controller will use a weighted average of 50% liquid pressure and 50% vapour pressure. Any percentage from 1 to 99% will give an appropriate weighted average between the two pressures.



Please ensure all power is switched off before installing or maintaining this product.

Relay State and functional operation

Relay State	Function State	Wired contact	Relay State	Function State	Wired contact
Relay 1 off	Fans on	N/C	Relay 3 off	LLV = Open	N/C
Relay 1 on	Fans off	N/C	Relay 3 on	LLV = Closed	N/C
Relay 2 off	Lights on	N/C	Relay 4 off	Alarm Relay = Alarm	N/C
Relay 2 on	Lights off	N/C	Relay 4 on	Alarm Relay = OK	N/C
Relay 3 off	Suction or Trims off	N/C	Relay 4 off	Defrost Control off	N/O
Relay 3 on	Suction or Trims on	N/C	Relay 4 on	Defrost Control on	N/O
Relay 3 off	Alarm Relay = Alarm	N/C			
Relay 3 on	Alarm Relay = OK	N/C			

Relay and screen states during defrost

State	Pump Down	Defrost Min	Defrost Max	Drain Down	Fan Delay	Recovery
Screen:	DEF	DEF	DEF	DEF	DEF	REC
Def LED:	On	On	On	Off	Off	Off
Stepper Valve	Closed	Closed	Closed	Closed	Open	Open
RLY 1 Fans (On in DF)	On	On	On	On	Off	On
RLY 1 Fans (Off in DF)	On	Off	Off	Off	Off	On
RLY 2 Lights relay	On	On	On	On	On	On
RLY 3 Suction Line	Off	On	On	On	Off	Off
RLY 3 Trim on in defrost	On	On	On	On	On	On
RLY 3 Trim off in defrost	Off	Off	Off	Off	Off	On
RLY 3 Suction LLV	Off	Off	Off	Off	On	On
RLY 4 Defrost Relay	Off	On	On	Off	Off	Off

Defrost Termination

Defrost termination will be when the temperature parameter 'Def terminate' (P-44) has been reached on the 'defrost termination' probe. If the 'defrost termination' probe is not fitted, defrost termination will occur when:

- The 'coil in' probe reaches the set point (If fans are selected as 'off during defrost').
- Or
- The 'air off' probe reaches the set point (If fans are selected as 'on during defrost').

If the 'coil in' probe is not fitted, the 'air off' probe will be used. If the 'air off' probe is faulty termination will occur when the time-out period has elapsed.

Fan Delay after Defrost

The fans will come back on when:

- The fan delay time has elapsed if the 'fan delay mode' is set to time
- Or
- If the fan delay mode is set to 'temp', the fans will come on when the defrost termination probe reaches the fan delay set point, or on the time parameter, whichever occurs first.

If the 'defrost termination' probe is not fitted, the fans will come on when:

- The 'coil in' probe reaches the control set point (If fans are selected as 'off during defrost').
- Or
- The 'air off' probe reaches the control set point (If fans are selected as 'on during defrost').



Please ensure all power is switched off before installing or maintaining this product.

Network Configuration

The final section to setup is the network address. In all instances, this must be done before the controller is plugged into the site network.

For the Mercury there are two standard hardware variants; [RS232](#) interface or built in [IP](#) (See [Ordering details](#) for more information).

When using an Intuitive Mercury controller, the controller has to have the correct network card fitted (see [compatible network interfaces](#)). For connection to a Mercury Switch (Hub) or an IP Futura network interface, the standard fitment RS232 network card is utilised.

Mercury RS232 Variant & Intuitive Mercury

When logging a Mercury with an RS232 interface onto a network you must first connect the controller to a communications module, this is either a 485 Legacy, IP Futura or Mercury Switch.

IP Futura module & Intuitive Internal IP Network card

In an IP system there are two options;

- IP-L – setting rotary address of module to 000
- IP-r – setting rotary address of module to a unique number that is not 000

IP-L allows the user to statically assign an IP address in the controller which could be used, for example, when connecting the controllers onto a customer's local area network that does not use DHCP.

IP-r allows the network ID (rotary switch address) to be used by a system running a DHCP server (for example the RDM Data Manager) to issue out an IP address automatically.

IP-L

To configure the communication module or network card for IP-L, set all three rotary switches to zero. The module should then be connected to the controller. In the case of an Intuitive Mercury controller where the network card is already fitted, the controller should be powered off, all three rotary switches set to zero and the controller powered on.

- From within the device's display navigate to the 'nEt' menu and press the 'enter' key.
- 'IP-L' will be displayed, press enter again.
- The user can now set the address using the table below

Display	Option
IP-1	IP Address byte 1
IP-2	IP Address byte 2
IP-3	IP Address byte 3
IP-4	IP Address byte 4
nL	Network Mask Length (see the network mask length table below)
gt-1	Gateway Address byte 1
gt-2	Gateway Address byte 2
gt-3	Gateway Address byte 3
gt-4	Gateway Address byte 4
ESC	Exit network menu. Note: This option must be selected to save any changes made in this menu.

To ease setup, a single network mask length value is used. If the address has been specified with a network mask value in dotted IP format e.g. 255.255.255.0 then the table below gives the conversion:

Mask	Length	Mask	Length	Mask	Length
		255.255.254.0	23	255.254.0.0	15
255.255.255.252	30	255.255.252.0	22	255.252.0.0	14
255.255.255.248	29	255.255.248.0	21	255.248.0.0	13
255.255.255.240	28	255.255.240.0	20	255.240.0.0	12
255.255.255.224	27	255.255.224.0	19	255.224.0.0	11
255.255.255.192	26	255.255.192.0	18	255.192.0.0	10
255.255.255.128	25	255.255.128.0	17	255.128.0.0	09
255.255.255.0	24	255.255.0.0	16	255.0.0.0	08



Please ensure all power is switched off before installing or maintaining this product.

IP-r

To configure the communication module for IP-r, set the three rotary switches to give each controller a unique identifier. The module should then be connected to the controller and the network. In the case of an Intuitive Mercury controller where the network card is already fitted, the three rotary switches must be set when the controller is powered off, then power up before connecting to the network. To view the issued IP address from the DHCP server;

- Select 'nEt' from the function menu and press the 'Enter' key.
- 'IP-r' will be shown, press enter again
- Similar to the [tables](#) above, the network details can be viewed.

Mercury Switch

A similar process to that of the [IP Futura](#) can be used with the Mercury Switch. Please refer to the Mercury Switch user guide, which can be obtained from the RDM website, for information regarding connecting a controller to a network.

RS485 module/ Intuitive Internal RS485 Network card

Connecting an RS485 legacy Module or an Intuitive Internal RS485 network card to the controller will govern which set up screens available under the 'Net' menu. Both modules support the Genus protocol only. They are detailed below;

Display	Option
485t	1: 485 Genus Network
485A	RS485 device name. As it will appear on DMTouch's device list (RC00-0 – RC99-9)
gAdd	Shows underlying network address assigned to controller
rLog	Re-log the controller back onto the network
CLrA	Clear the address/ name from the controller
ESC	Exit network menu. Note: this option must be selected to save any changes made in this menu.

- Ensure the 485t is set to '1' (Genus RS485)
- Provide a unique device alias under the 485A menu (e.g. 01-5)
- Press the 'ESC' to save

The green network LED will flash to show it is attempting to log on and go solid when connected.

Mercury IP Variant

When logging a Mercury with an in-built IP interface it be connected directly into an IP network without the need of a communications module.

When networking the Ethernet variant, the 'Net' menu will have the following menus:

Display	Option
IP-L / IP-r	Read/ Write Static IP address / Read Only DHCP IP address
Id	The 3 digit network address
AtyP	IP-r / IP-L selection
ESC	Exit Menu

Similar to the [IP Futura setup](#), IP-L allows you to fix a static IP address into the controller and IP-r allows you to give each controller on the system a unique network number (using the Id).

- To firstly select between IP-L and IP-r navigate to 'AtyP'.

IP-r

Once IP-r is selected the controller must be given a unique 3 digit 'network address' that no other device on the network has (**note** if logging on to a Data Manager, this will be the device ID). Once the ID has been set connect the controller to the IP network for it then to be given an IP address by the DHCP server. To view the IP address given, within the Net menu, navigate to 'IP-r'.



Please ensure all power is switched off before installing or maintaining this product.

IP-L

If IP-L has been selected from the 'AtyP' menu the IP address must be set in the controller by navigating to 'IP-L' within the 'Net' menu. The following menus will be available:

Display	Option
IP-1	IP Address byte 1
IP-2	IP Address byte 2
IP-3	IP Address byte 3
IP-4	IP Address byte 4
nL	Network Mask Length (see the network mask length table above)
gt-1	Gateway Address byte 1
gt-2	Gateway Address byte 2
gt-3	Gateway Address byte 3
gt-4	Gateway Address byte 4
ESC	Exit network menu. Note: this option must be selected to save any changes made in this menu

Once the IP address has been entered, the controller can be connected to the IP network.



Please ensure all power is switched off before installing or maintaining this product.

Viewing IO

Apart from setting up the controller, you can also view the status of the inputs and outputs and controller states. From the function menu, select 'I/O', press enter. You can now scroll through the IO table as set out below. Inputs and outputs that do not apply to a particular controller type will be greyed out.

Input / Output Table

Number	IO	Range* °C (°F)	Step	Units	Case	Coldroom
I-01	Control Temp.	-42 to 60 (-43.6 to 140)	0.1	Deg	✓	✓
I-02	Display temp	-42 to 60 (-43.6 to 140)	0.1	Deg	✓	✓
I-03	Air on Probe	-42 to 60 (-43.6 to 140)	0.1	Deg	✓	✓
I-04	Air off Probe	-42 to 60 (-43.6 to 140)	0.1	Deg	✓	✓
I-05	Evaporator Probe	-49 to 60 (-56.2 to 140)	0.1	Deg	✓	✓
I-06	Suction Line Probe	-49 to 60 (-56.2 to 140)	0.1	Deg	✓	✓
I-07	Superheat	-30 to 60 (-54 to 108)	0.1	Deg	✓	✓
I-08	Logging Probe	-49 to 60 (-56.2 to 140)	0.1	Deg	✓	✓
I-09	Defrost Probe	-49 to 60 (-56.2 to 140)	0.1	Deg	✓	✓
I-10	Alarm Temp	-49 to 60 (-56.2 to 140)	0.1	Deg	✓	✓
I-11	Case Clean	0 (Off), 1 (On)			✓	✓
I-12	Door Sensor	0 (Closed), 1 (Open)				✓
I-13	Person Trapped	0 (OK), 1 (Alarm)				✓
I-14	External Defrost	0 (Off), 1 (On)			✓	✓
I-15	Monitor Probe	-49 to 60 (-56.2 to 140)	0.1	Deg	✓	✓
I-16	Remote Evaporator Temp	-49 to 60 (-56.2 to 140)	0.1	Deg	✓	✓
I-17	MOP	0 (Off), 1 (On)			✓	✓
I-18	Hub Trim Level	0 to 100	1.0	%	✓	
I-19	Divide Input	0 to 100	1.0	%	✓	✓
I-20	Remote Pressure	-3.4 to 100.0	0.1	Bar	✓	✓
I-21	Local Pressure	-3.4 to 100.0	0.1	Bar	✓	✓
I-22	Local Calculated Temp.	-49 to 60 (-56.2 to 140)	0.1	Deg	✓	✓
I-25	Shut Input	0 (Off), 1 (On)			✓	
O-01	Liquid Line Valve	0 (Open), 1 (Closed)			✓	✓
O-02	Suction Line / Trims	0 (Open), 1 (Closed)			✓	✓
O-05	Defrost Control	0 (Off), 1 (On)			✓	✓
O-06	Lights	0 (Off), 1 (On)			✓	✓
O-07	Case Fans	0 (Off), 1 (On)			✓	✓
O-09	Valve Opening	0 to 100	0.1	%	✓	✓
O-10	Last Def. Time	00:00 to 23:59		hh:mm	✓	✓
O-11	Last Def. Length	00:00 to 03:00		hh:mm	✓	✓
O-12	Last Def. Ctrl Temp.	-49 to 60 (-56.2 to 140)	0.1	Deg	✓	✓
O-13	Last Def. Type	0 (None), 1 (Internal), 2 (External), 3 (Network), 4 (Display), 5 (Timed) 6 (Forced), 7 (Skipped)			✓	✓
O-15	Alarm 1 Relay	0 (Unused), 1 (OK), 2 (Alarm)			✓	✓
O-16	Alarm 2 Relay	0 (Unused), 1 (OK), 2 (Alarm)			✓	✓
O-17	Remote Relay	0 (Off), 1 (On)			✓	✓
O-18	Run Time	0 - 128 K Hours	1		✓	✓
O-19	Valve Step	0 - 6400	1		✓	✓
O-20	Door Open Time	00:00 to 23:59		hh:mm		✓
O-21	Door Open Length	00:00 to 03:00		hh:mm		✓
O-30	Set Point Offset	-49 to 60 (-56.2 to 140)	0.1	Deg.	✓	✓
O-31	Trim Off Period	00:00 to 05:00	00:01	mm:ss	✓	
S-01	Control State	0 (Stabilise), 1 (Normal), 2 (Defrost Min), 3 (Defrost Max), 4 (Drain Down), 5 (Fan Delay), 6 Recovery), 7 (OT Alarm), 8 (UT Alarm), 9 (Fans Only), 10 (Lights Only), 11 (Case Off), 12 (Pump Down), 13 (Defrost Hold), 14 (Shut).			✓	✓



Please ensure all power is switched off before installing or maintaining this product.

S-02	Valve State	0 (Off), 1 (Start), 2 (Run), 3 (Problem), 4 (Fail), 5 (Initial).			✓	✓
------	-------------	--	--	--	---	---

* Range is dependent on probe type.

Display Messages

The following alarms and messages can appear on the Mercury display.

Display Message	System status	Display Message	System status
Ft	Control Fault	Plt3	Plant Fault 3
Prb1	Probe 1 Fault	Plt4	Plant Fault 4
Prb2	Probe 2 Fault	FanS ONLY	Controller in Fans Only
Prb3	Probe 3 Fault	LitS ONLY	Controller in Lights Only
Prb4	Probe 4 Fault	CASE OFF	Controller in Case Off
Prb5	Probe 5 Fault	Ot	Over Temperature Alarm
Prb6	Probe 6 Fault	Ut	Under Temperature Alarm
rEC	Control State in Recovery	door	Door Open Alarm
dEF	Control Sate in Defrost	TrAP	Person Trapped Alarm
AL	Control State in Alarm	LgOt	Log Probe Over Temperature
Plt1	Plant fault 1	LgUt	Log Probe Under Temperature
Plt2	Plant Fault 2		

Network Alarms

The table below shows the text and associated type number that is sent to the system 'front end'. The type number is normally used to provide different alarm actions.

Alarm text	Type # (index)	Alarm text	Type # (index)
Missed defrost	15	Product under temperature	9
Plant Fault 1,2,3 or 4	3	Person Trapped	1
Case over temperature	4	Monitor Probe OT	12
Case under temperature	5	Case Clean	29
Probe 1,2,3,4,5 or 6 Faulty	6	Remote evap temperature	6
Door Left Open	2	Transducer Fault	6
Product over temperature	8	Load Shedding	7
MOP Alarm	3	Lights Only	29
Valve Shut	2	Stepper Fault	3



Please ensure all power is switched off before installing or maintaining this product.

Modifying controller states

During normal operation you can change the following states from the function menu

Fans Only 'FanS'

Selecting the Fans Only option will put the controller into the Fans Only state if the current state is not Fans Only. If the current state is Fans Only then the controller will change to the Normal state. Selecting this option will exit the setup menu automatically. The display will show 'FanS OnLy'.

If a remote display with key switch is being used, this function can be invoked by turning the key switch to the fans only position (90 degrees clockwise) with parameter P85 set to 'fans'.

Case Off 'CASE'

Selecting the Case Off option will put the controller into the Case Off state if the current state is not Case Off. If the current state is Case Off then the controller will change to the Normal state. Selecting this option will exit the setup menu automatically. The display will show 'CASE OFF'. An alarm is generated, fixed delay of 1 minute, when the controller is placed into the Case Off state.

If a remote display with key switch is being used, this function can be invoked by turning the key switch to the case-off position. (Clockwise 90 degrees) with parameter P85 set to 'case'.

Lights Only 'Ligt'

Selecting the Lights Only option will put the controller into the Lights Only state if the current state is not Lights Only. If the current state is Lights Only then the controller will change to the Normal state. Selecting this option will exit the setup menu automatically. The display will show 'LitS OnLy'. An alarm is generated, fixed delay of 1 minute, when the controller is placed into the Lights Only state.

Note: When lights are being used in 'Remote' mode with a timing channel:

If the controller goes offline, the lights are turned ON after a delay of 5 minutes. The lights will stay on until the controller comes back on-line where they will revert to the state of the timing channel being used.

Probe Offset

This feature allows each probe value to be modified by an 'offset'. Offset values are from -10°C (-18°F) to +10°C (+18°F) and on a channel basis. Example C1 = Probe 1.



Please ensure all power is switched off before installing or maintaining this product.

Remote Commands

The following commands can be used by a Data Builder program:

Command	Value to send	Description	Conditions
Defrost Command	1	Initiates a defrost cycle	Defrost mode: remote
Defrost Command	3	Terminates the defrost	Defrost mode: remote Defrost hold: On Defrost min state complete
Trim Command	0 to 100%	Sets the trim level to this value (Trim period is 5 min)	Relay 4 mode: Trim Heater
Setpoint Command	+/-18	Is added to or subtracted from the setpoint	
Case Off Command	5 8 0	Sets the controller to Case Off Sets the controller to Lights Only Restores the controller from Case Off to Normal	
Haccp Command	0 1 2	HACCP LED OFF HACCP LED On HACCP LED Flashes	
Button Command	0 1	Buttons backlights Off Buttons backlights On	
EEV Command	2 1	Shuts the valve off Restores the valve to normal operation	
Divider Command	0 to 100%	Sets the maximum valve opening to this percentage.	MOP input from Merc PHI hub must be 'Off'.

Use an 'Analogue Out' block configured to the controller name and in the value field type in the command you require. Use a 'Setting block' as the input to the 'Analogue Out' block to send the Value.

See Example on the right, which sets the Trim Heater on BY10-1 at 40%.

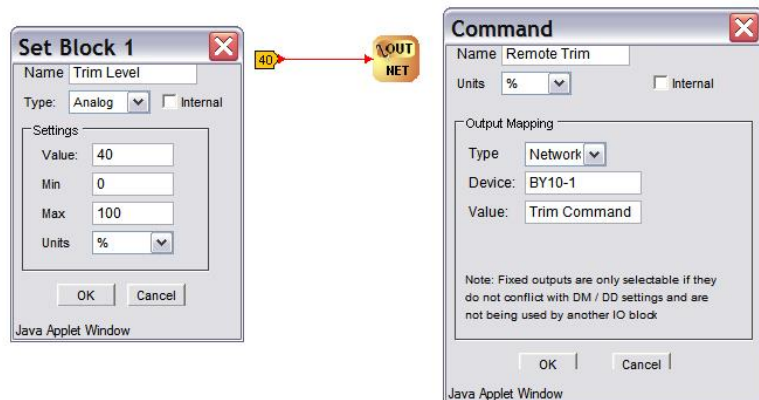

Please ensure all power is switched off before installing or maintaining this product.

Specification

	Mercury Controller 24v PR0740	Intuitive Mercury 240v Controller PR095X	Intuitive Mercury 24v Controller PR075X & PR076X
Power requirements			
Supply Voltage Range	24 Vac or 24Vdc $\pm 10\%$ (DC only if using a power store PR0627)	100 – 240 Vac $\pm 10\%$	24 Vac or 24Vdc $\pm 10\%$ (DC only if using a power store PR0627)
Supply Frequency	50 – 60 Hz	50 – 60 Hz	50 – 60 Hz
Maximum supply current	2 Amps (Total maximum supply current is dependant on type of valve used)	2 Amps (Total maximum supply current is dependant on type of valve used)	2 Amps (Total maximum supply current is dependant on type of valve used)
Typical supply current	<1 Amp	<1 Amp	<1 Amp
General			
Operating temperature range	-10°C to 60°C (14°F to 140°F)	-10°C to +60°C (14°F to 140°F)	-100C to +600C (14°F to 140°F)
Storage temperature range	-20°C to 65°C (-4°F to 149°F)	-20°C to +65°C (-4°F to 149°F)	-200C to +650C (-4°F to 149°F)
Environmental	Indoor use at altitudes up to 2000m, pollution degree 2, installation category II. Voltage fluctuations not to exceed $\pm 10\%$ of nominal voltage.	Indoor use at altitudes up to 2000m, pollution degree 1, installation category II. Voltage fluctuations not to exceed $\pm 10\%$ of nominal voltage.	Indoor use at altitudes up to 2000m, pollution degree 1, installation category II. Voltage fluctuations not to exceed $\pm 10\%$ of nominal voltage.
Size	78mm (W) x 36mm (H) x 110mm (D)	157mm (W) x 67mm (H) x 120 (D)	157mm (W) x 67mm (H) x 120 (D)
Approx. Weight	177 grams	500 grams	500 grams
Safety	EN61010	EN61010	EN61010
EMC	EN61326; 2013	EN61326; 1997 +Amdt. A1; 1998	EN61326; 1997 +Amdt. A1; 1998
Ventilation	There is no requirement for forced cooling ventilation	There is no requirement for forced cooling ventilation	There is no requirement for forced cooling ventilation
Class 2 Insulation	No protective Earth is required and none should be fitted	No protective Earth is required and none should be fitted	No protective Earth is required and none should be fitted
Supply Fuse	The host equipment must provide a suitable external over-current protection device such as: - Fuse: 2A Anti-surge (T) HRC conforming to IEC 60127	Built in fuse holder, fuse 2A 240Vac Anti-surge (T) HRC conforming to IEC60127, 32 x 6.3mm	Built in fuse holder, fuse 2A 240Vac Anti-surge (T) HRC conforming to IEC60127, 32 x 6.3mm
Or MCB	2A, Type C conforming to BS EN 60898	2A, 240 VAC Type C conforming to BS EN 60898. Note: device has integral 2A fuse	2A, 240 VAC Type C conforming to BS EN 60898. Note: device has integral 2A fuse
Connections	All relay and power connections are plug in with screw terminals, maximum 1.5mm ² CSA wire size (16 AWG 40pprox.).	All relay and power connections are plug in with screw terminals, maximum 1.5mm ² CSA wire size (16 AWG 40pprox.).	All relay and power connections are plug in with screw terminals, maximum 1.5mm ² CSA wire size (16 AWG pprox.).
Relay Fuse	Not Fitted	10A 240Vac Anti-surge (T) HRC conforming to IEC60127, 32 x 6.3mm	10A 240Vac Anti-surge (T) HRC conforming to IEC60127, 32 x 6.3mm
Relay Specification			
	Relay 1 – 3	Relays 1 – 5	Relays 1 – 5
Max current	6A Resistive (Cos ϕ = 1) 2A Inductive (Cos ϕ = 0.4)	10A Resistive (Cos ϕ = 1) 3A Inductive (Cos ϕ = 0.4)	10A Resistive (Cos ϕ = 1) 3A Inductive (Cos ϕ = 0.4)
Max voltage	250Vac, 30Vdc	250Vac. 30V dc	250Vac. 30V dc
Relay Fuse	N/A	10A 240Vac Anti-surge (T) HRC conforming to IEC60127, 32 x 6.3mm	10A 240Vac Anti-surge (T) HRC conforming to IEC60127, 32 x 6.3mm
	Relay 4		
Max current	3A (non-inductive), COS ϕ =0.4 2A (inductive load)		
Max voltage	250Vac (Internal supply)		
	Mechanical Relay Operational Life	Mechanical Relay Operational Life	Mechanical Relay Operational Life
Switching 3A load (non-inductive)	350,000 operations	Contact RDM for current specification	Contact RDM for current specification
Switching 500mA load (non-inductive)	2,000,000 operations	Contact RDM for current specification	Contact RDM for current specification
For compliance with the LVD, All relay commons must be at the same potential as the supply voltage			



Please ensure all power is switched off before installing or maintaining this product.

Safety	Conforms to EN60730-1 based on UL 60950-1; UL 62368-1 as referenced to IEC60730-1		
Valve Output	Bipolar Stepper Motor 24V 8W, Maximum current cannot exceed 825mA, Chopper Drive. Maximum settable peak current per motor coil 500mA.		
Inputs			
Probe Input resistance	3.01K Ohms (for PTC or NTC type probes)	3.01K Ohms (for PTC or NTC type probes)	3.01K Ohms (for PTC or NTC type probes)
Probe Input type	Selectable. See: Units	Selectable. See: Units	Selectable. See: Units
Transducer 0-10V	Connect a 0-10v signal	Connect a 0-10v signal	Connect a 0-10v signal
Transducer 4-20mA	4-20mA current loop, provides a 12 Vdc output to power the pressure transducer. See wiring	4-20mA current loop, provides a 12 Vdc output to power the pressure transducer. See wiring	4-20mA current loop, provides a 12 Vdc output to power the pressure transducer. See wiring
Digital Inputs	Volt Free	Volt Free	Volt Free
Comms			
Serial Variant	RS232 with flow control	RS232 with flow control	RS232 with flow control
Ethernet Variant	IP comms	IP comms	IP comms



Please ensure all power is switched off before installing or maintaining this product.

Installation & Dimensions

Panel Cut-out and Clearances

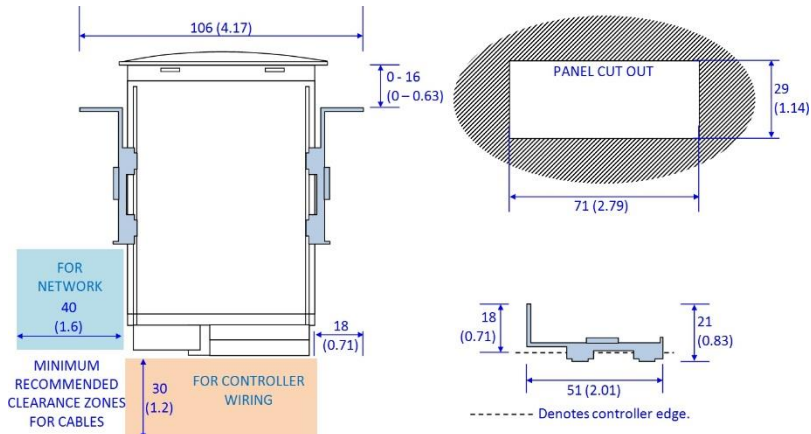

Fixing

The controller is fixed by sliding the 2 plastic retaining clips up to rear of the panel. These clips have a ratchet action and can be removed by holding in the clip sides and sliding back.

There is no requirement for forced cooling ventilation

Dimensions – Mercury

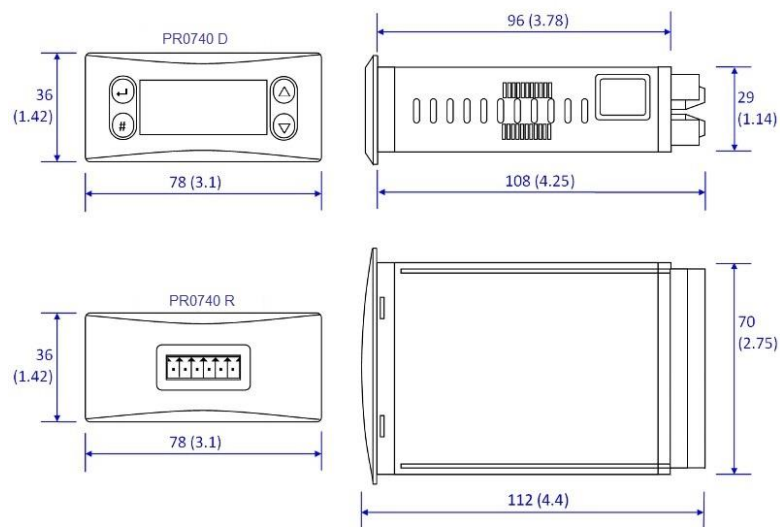

Please ensure all power is switched off before installing or maintaining this product.

Dimensions – Intuitive Mercury Controller

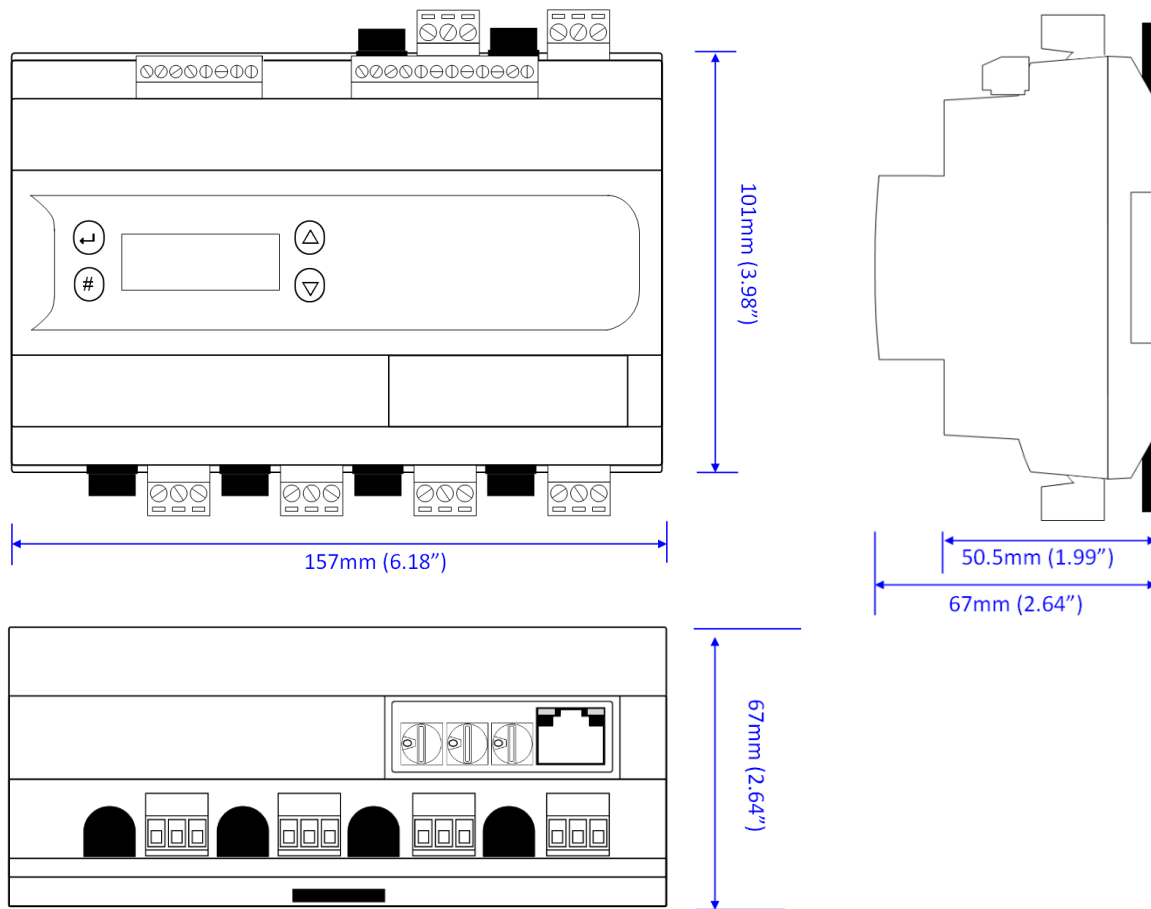

Intuitive Mercury Mounting Instructions

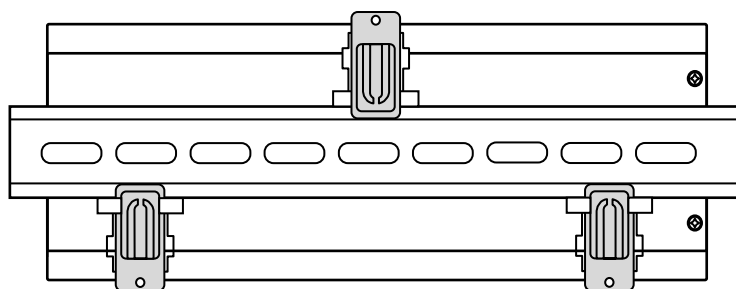

Three clips fix the Intuitive Mercury securely to DIN rail. Pull each clip until it "clicks" to remove the controller. Each clip has a mounting hole to provide an alternative fixing mechanism to DIN mounting.

Cleaning

Do not wet the controller when cleaning. Clean the front by wiping with slightly dampened lint free cloth.



Please ensure all power is switched off before installing or maintaining this product.

Appendix 1: Defrost Cycles

Fans On in Defrost

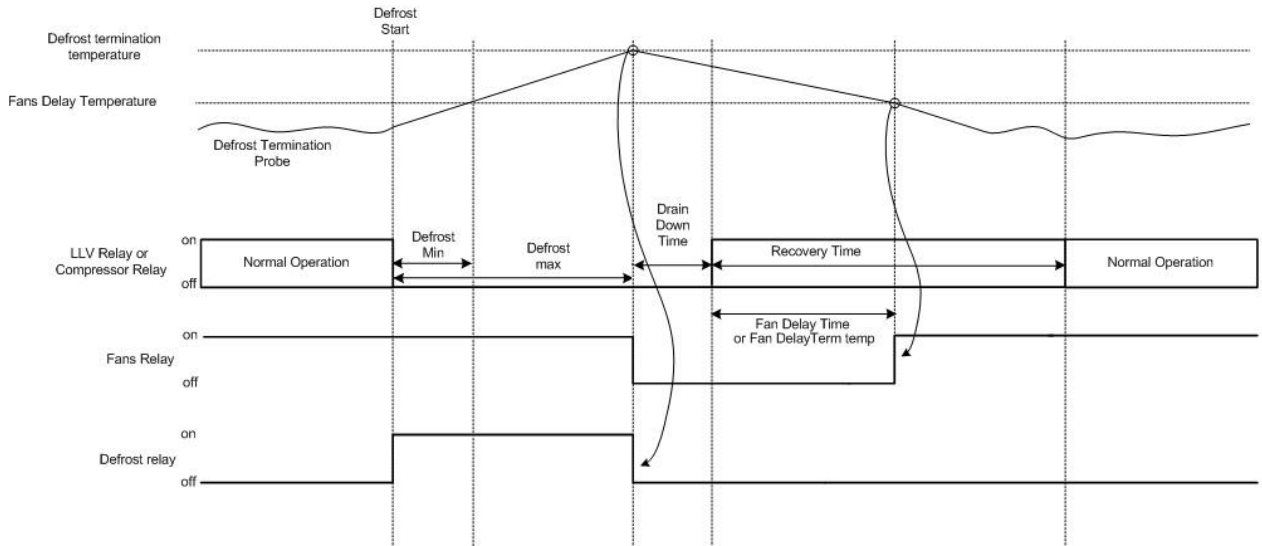

Fans Off in Defrost

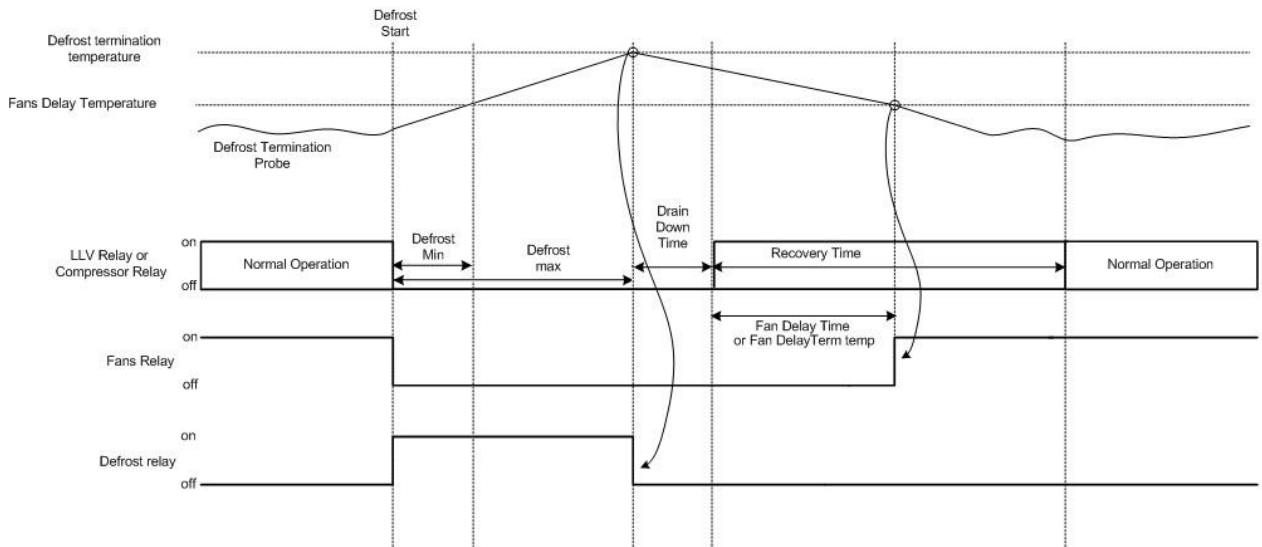

Please ensure all power is switched off before installing or maintaining this product.

Appendix 2: Trim Heater Control via Mercury/Intuitive Range

Energy savings via the RDM's range of case controllers can be achieved in a number of ways. One of which is pulsing the trim heater relay off for a given period of time. One way to pulse the trim heater is by configuring P-14. For greater energy savings the Data Manager Energy feature trim control or the Mercury Switch trim control feature can be used. These two options pulse the trim relay dependant on the actual shop floor humidity levels. Thus if the shop floor humidity is relatively low the trim heaters can be pulsed off for longer durations. Please see the relevant user guides for further details.

Due to the high switching rate, trim heaters must not be switched directly from the Mercury trim heater relay and a Trim Heater Pulse Module (PR0723) must be used in all instances of trim control. This module is fitted in between the trim heater of the case and the relay output of the Controller which is pulsing the heater. The trim heater module output provides a smoother power distribution, compared to using the relay output directly, as it switches at the zero voltage crossover point. Switching the trim heater on and off via a normal relay, without using the RDM trim heater pulse module, may damage the trim heater and reduce the operational life of the heater.

Please see the Trim Heater Pulse Module user guide for further details.

Appendix 3: Step Speed (Frequency Hz)

When setting the Step Speed, P-33, the following table applies.

Step Speed Entered	Actual Speed Set (Hz)	Step Speed Entered	Actual Speed Set (Hz)
500 and above	500	86 to 90	90
251 to 333	333	81 to 85	85
201 to 250	250	76 to 80	80
167 to 200	200	71 to 75	75
144 to 166	166	66 to 70	70
126 to 143	143	61 to 65	65
112 to 125	125	56 to 60	60
101 to 111	111	51 to 55	55
96 to 100	100	50 and below	50
91 to 95	95		

Please confirm with the Stepper valve manufacturer datasheets to select the correct step frequency.



Please ensure all power is switched off before installing or maintaining this product.

Appendix 4: Webpage Appearance

It is possible to view the controller across an IP connection using one of the methods outlined in the [Network Configuration](#) section

The following screens are samples of how values and settings appear when viewed through a PC/Laptop connection.

Case Controller (HT)

Mercury3 Stepper v3.2

Stepper v1.2

Time 10:09:18 24/07/20

Current Status

Control temp.	1.8	°C
Control State	Normal	

Current Alarms

None

The user has a choice of entering the following pages: - **Inputs & Outputs, Parameters, Alarms, Logs & Configure.**

Inputs & Outputs

Inputs & Outputs

Inputs			Outputs			States	
Control temp.	1.8	°C	Valve Opening	10.0	%	Control State	Normal
Display temp.	1.8	°C	Liq. Line Valve	Open		Valve State	Run
Air on Probe	3.0	°C	Suc. Line/Trims	Off			
Air off Probe	0.6	°C	Defrost Control	Off			
Evaporator Probe	-2.1	°C	Lights	On			
Suc. Line Probe	3.6	°C	Case Fans	On			
Superheat	5.7	°C	Last Def. Time	00:00	hh:mm		
Logging Probe	N/A	°C	Last Def. Length	00:00	hh:mm		
Defrost Probe	N/A	°C	Last Def. Temp.	0.0	°C		
Alarm temp.	0.6	°C	Last Def. Type	None			
Plant Fault 1	OK		Setpoint Offset	N/A	°C		
Plant Fault 2	OK		Trim Off Period	00:00	mm:ss		
Plant Fault 3	OK		Alm Relay 1	Unused			
Case Clean	Off		Alm Relay 2	Unused			
Monitor Probe	N/A	°C	Remote Rly3	Off			
Rem Evap Temp	N/A	°C	Run Time	1	K Hrs		
Ext Defrost	Off		Valve Step	48			
MOP	Off						
Hub Trim Level	N/A	%					
Div Input	N/A	%					
Remote Press	N/A	bar					
Local Press	N/A	bar					
Local Calc Temp	N/A	°C					
Shut Input	Unused						

This is view only screen and shows the states of the inputs and outputs.



Please ensure all power is switched off before installing or maintaining this product.

Parameters

Parameters					
Control	EEV	Alarms	Defrost	Lights	Pressure
Parameter Name	Value	Units			
Cut-in temp	0.0	°C			
Cut-in diff.	1.5	°C			
Control weight	50	%			
Display weight	50	%			
Alarm weight	0	%			
Superheat Ref.	6.0	°C			
Response On	10				
Response Off	10				
Relay 3 Mode	Suc.Line				
Trim in Defrost	Off				
Trim Level	100	%			
Key Switch	KeyOff				
Ctrl Probe Type	Air On				
Resistor Case Off	Off				
Fans Temp Mode	Off				
Fans Off Temp	8.0	°C			
Probe 5 Select	Defrost				
Relay 2 Mode	Lights				
Prb1 Resistor	Plnt3 NO				
Service Time	60	K Hrs			
Switch Resistors	On				
Lights CaseOff	Off				
Digital 1 Mode	Plnt1 NO				
Digital 2 Mode	Case Swt				
Cut-in Offset	5.0	°C			

This is a view only screen and shows the parameter settings.

Alarms

Alarms		
Reason	Occurred	Cleared
Case over temperature	09:48:49 21/07/20	
Probe Fault 6	09:09:58 20/07/20	09:18:49 21/07/20

This is a view only screen showing the alarm log.

Logs

Logs									
<<<	<<	<	>	>>	>>>				
	11:34:35 22/07/20	11:34:40 22/07/20	11:34:45 22/07/20	11:34:50 22/07/20	11:34:55 22/07/20	11:35:00 22/07/20	11:35:05 22/07/20	11:35:10 22/07/20	
Air off Probe	17.0	17.0	17.0	17.0	17.0	17.0	17.0	17.0	17.0
Evaporator Probe	N/A	N/A	N/A	N/A	N/A	N/A	N/A	N/A	N/A
Logging Probe	N/A	N/A	N/A	N/A	N/A	N/A	N/A	N/A	N/A
Defrost Probe	N/A	N/A	N/A	N/A	N/A	N/A	N/A	N/A	N/A
Valve Opening	0.0	0.0	0.0	0.0	0.0	0.0	0.0	0.0	0.0

This is a view only screen showing the device's log.



Please ensure all power is switched off before installing or maintaining this product.

Configure

Alternatively, click on the **Configure** button to access the setup menu.

Note: login credentials required to access Configure menu are as follows;

Username: `service`
Password: `1234`

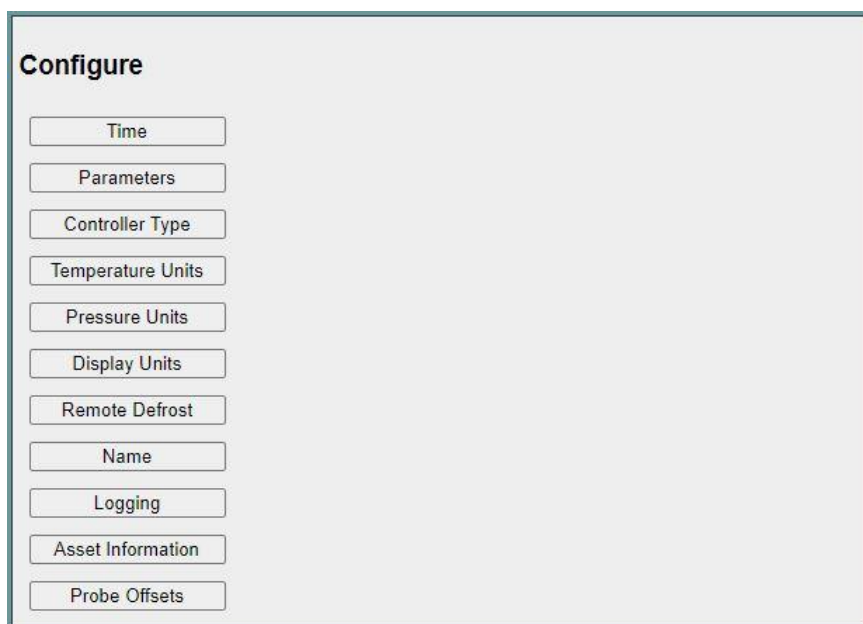

The screenshot shows a 'Configure' menu with the following options listed vertically in rectangular buttons: Time, Parameters, Controller Type, Temperature Units, Pressure Units, Display Units, Remote Defrost, Name, Logging, Asset Information, and Probe Offsets.

This screen allows the user to configure the controller and set-up the following: - Time, Parameters, Controller Type, Temperature Units, Pressure Units, Display Units, Remote Defrost, Name, Logging, Asset Information and Probe Offsets.

Time

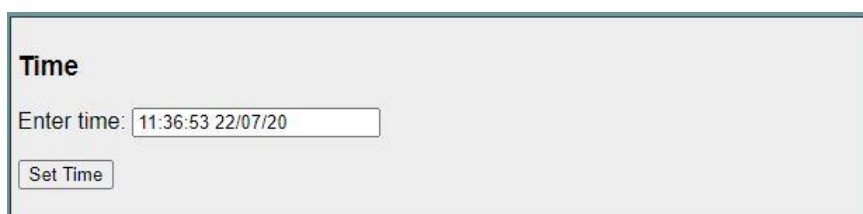

The screenshot shows a 'Time' configuration screen. It features a text input field labeled 'Enter time:' containing the value '11:36:53 22/07/20'. Below the input field is a button labeled 'Set Time'.

Enter the time and date in the format displayed and press "Set Time" to update the controller. A screen showing the set time will be displayed, and then revert to the initial (Home) screen.



Please ensure all power is switched off before installing or maintaining this product.

Parameters

Set Parameters

Use Set Parameters button to save changes before changing section

Control
EEV
Alarms
Defrost
Lights
Pressure

Parameter Name	Low	High	Default	Value	Units
Cut-in temp	-42.0	30.0	-20.0	<input type="text" value="-20.0"/>	°C
Cut-in diff.	0.0	10.0	2.0	<input type="text" value="2.0"/>	°C
Control weight	0	100	50	<input type="text" value="50"/>	%
Display weight	0	100	50	<input type="text" value="50"/>	%
Alarm weight	0	100	0	<input type="text" value="0"/>	%
Superheat Ref.	0.0	12.0	6.0	<input type="text" value="6.0"/>	°C
Response On	1	30	10	<input type="text" value="10"/>	
Response Off	1	30	10	<input type="text" value="10"/>	
Relay 3 Mode				<input type="text" value="Suc.Line"/>	
Trim in Defrost				<input type="text" value="Off"/>	
Trim Level	0	100	100	<input type="text" value="100"/>	%
Key Switch				<input type="text" value="KeyOff"/>	
Ctrl Probe Type				<input type="text" value="Air On"/>	
Resistor Case Off				<input type="text" value="Off"/>	
Fans Temp Mode				<input type="text" value="Off"/>	
Fans Off Temp	-42.0	30.0	-10.0	<input type="text" value="-10.0"/>	°C
Probe 5 Select				<input type="text" value="Defrost"/>	
Relay 2 Mode				<input type="text" value="Lights"/>	
Prb1 Resistor				<input type="text" value="Plnt3 NO"/>	
Service Time	0	128	60	<input type="text" value="60"/>	K Hrs
Switch Resistors				<input type="text" value="On"/>	
Lights CaseOff				<input type="text" value="Unused"/>	
Digital 1 Mode				<input type="text" value="Plnt1 NO"/>	
Digital 2 Mode				<input type="text" value="Case Swt"/>	
Cut-in Offset	-30.0	30.0	5.0	<input type="text" value="5.0"/>	°C

This screen allows the parameters to be changed. Once the values are changed, the "Set Parameter" button must be clicked to set the parameters into the controller. A screen will show the number of parameters and the number changed, then revert back to the Home screen.

Controller Type

Controller Type

This screen allows the user to select the controller type.



Please ensure all power is switched off before installing or maintaining this product.

Temperature Units

Temperature Units

PT1000 °C ▾

Set Units

This screen allows the user to set the probe type for the controller and if it's in degrees Centigrade or Fahrenheit.

Pressure Units

Pressure Units

bar ▾

Set Units

This screen allows the user to set the pressure units displayed to Bar or PSI.

Display Units

Display Units

Decimal ▾

Set Display Units

This screen allows the user to set if the display on the controller will display only whole numbers (Whole) or whole numbers and tenths (Decimal).

Remote Defrost

Force Remote Defrost

Remote Defrost

This screen allows the user to send a remote defrost to the controller (note: defrost mode must be set to local).

Name

Name

Enter Name:

Set Name

This screen allows the user to give the controller a name. Type in a name of your choice (upper or lower case alpha-numeric) up to 32 characters. Click "Set Name" to load into the controller. A screen will show the name has been set and then revert back to the Home screen. (The Home screen will also now show the controller name).



Please ensure all power is switched off before installing or maintaining this product.

Logging

Logging

Set 1		Set 2	
Log Interval	5s ▾	Log Interval	None ▾
Control temp.	<input type="checkbox"/>	Control temp.	<input type="checkbox"/>
Display temp.	<input type="checkbox"/>	Display temp.	<input type="checkbox"/>
Air on Probe	<input type="checkbox"/>	Air on Probe	<input type="checkbox"/>
Air off Probe	<input checked="" type="checkbox"/>	Air off Probe	<input type="checkbox"/>
Evaporator Probe	<input checked="" type="checkbox"/>	Evaporator Probe	<input type="checkbox"/>
Suc. Line Probe	<input type="checkbox"/>	Suc. Line Probe	<input type="checkbox"/>
Superheat	<input type="checkbox"/>	Superheat	<input type="checkbox"/>
Logging Probe	<input checked="" type="checkbox"/>	Logging Probe	<input type="checkbox"/>
Defrost Probe	<input checked="" type="checkbox"/>	Defrost Probe	<input type="checkbox"/>
Alarm temp.	<input type="checkbox"/>	Alarm temp.	<input type="checkbox"/>
Valve Opening	<input checked="" type="checkbox"/>	Valve Opening	<input type="checkbox"/>
Liq. Line Valve	<input type="checkbox"/>	Liq. Line Valve	<input type="checkbox"/>
Suc. Line/Trims	<input type="checkbox"/>	Suc. Line/Trims	<input type="checkbox"/>
Defrost Control	<input type="checkbox"/>	Defrost Control	<input type="checkbox"/>
Lights	<input type="checkbox"/>	Lights	<input type="checkbox"/>

This screen allows the user to set the logging features. There are two sets so that values can have different log intervals.

Set the interval required on set1 and set 2, tick the required values to be logged, then click "Set Values" to load into the controller.

A screen will display "Log configuration set" then revert back to the Home page.

Asset Information

Asset Information

Controller		Equipment Manufacturer	
Model		Manufacturer	
Serial No		Model	
Date		Serial No	
		Date	
Installed Fixture		Refurbished Fixture	
Asset		Refurb By	
Installer		Re-Asset	
Date		Installer	
		Date	

This screen allows the user to set asset information into the controller.

Caution: This is a once only operation.

Click "Set Information" and follow the on screen instructions to set up your asset information.



Please ensure all power is switched off before installing or maintaining this product.

Probe Offsets

Probe Offsets

Probe	Low	High	Value	Units
1	-10	10	<input type="text" value="0.0"/>	°C
2	-10	10	<input type="text" value="0.0"/>	°C
3	-10	10	<input type="text" value="0.0"/>	°C
4	-10	10	<input type="text" value="0.0"/>	°C
5	-10	10	<input type="text" value="0.0"/>	°C
6	-10	10	<input type="text" value="0.0"/>	°C

This screen allows the user to set a probe offset between to any of the six probes connected to the controller.

Disclaimer

The specifications of the product detailed in this document may change without notice. RDM Ltd shall not be liable for errors or omissions, for incidental or consequential damages, directly or indirectly, in connection with the furnishing, performance or misuse of this product or document.

Revision History

Software 24v	Software 240v	Doc Revision	Date	Changes
3.1		A	09/08/2018	Introduction of Mercury 3 Stepper
3.1		B	08/10/2018	Duplicate parameter numbers P-100 & P-101 corrected in user guide.
3.1		B	02/11/2018	Power store details updated.
3.1		D	22/11/2018	Parameter table amended.
3.1		E	29/11/2018	Parameter number P-05 corrected to P-128 in overdrive description.
3.1		F	29/11/2018	I/O Table Updated, Appendix 3 added
3.1		G	31/05/2019	I/O Table updated. Contact details updated.
3.3		A	20/08/2019	Support added for R454C and R455A. Ability to use a custom Refrigerant table added.
3.5		A	17/10/2019	Selecting Half Steps will automatically double the steps
3.5		B	04/11/2019	MOP units changed from temperature to pressure.
3.5		C	10/01/2020	Update to Specification
3.5	3.0	D	04/08/2020	Intuitive hardware added



Please ensure all power is switched off before installing or maintaining this product.

Group Offices

RDM Group Head Office

80 Johnstone Avenue
Hillington Industrial Estate
Glasgow
G52 4NZ
United Kingdom

+44 (0)141 810 2828
support@resourcedm.com

RDM USA

9441 Science Center Drive
New Hope
Minneapolis
MN 55428
United States

+1 612 354 3923
usasupport@resourcedm.com

RDM Asia

Sky Park at One City
Jalan USJ 25/1
47650 Subang Jaya
Selangor
Malaysia

+60 3 5022 3188
asiatech@resourcedm.com



Visit www.resourcedm.com/support for more information on RDM solutions, additional product documentation and software downloads.

While every effort is made to ensure the information given within this document is accurate, Resource Data Management Ltd shall not be liable for errors or omissions, for incidental or consequential damages, directly or indirectly, in connection with the furnishing, performance or misuse of this product or document. All specifications are subject to change without notice. See www.resourcedm.com for terms and conditions of sales.