

Mercury Switch User Guide



For Products: -

**PR0018
PR0018-PHI**



Ensure that all power is switched off before installing or maintaining this product

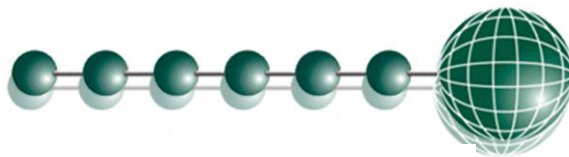

Table of Contents:

THE MERCURY SWITCH 3

Description 3

Front View 3

Rear View 3

Top View 4

Connection to Mercury Controllers: 4

 RS232 Lead Lengths 4

Connection to other IP equipment 4

Connection to another Mercury Hub/Switch or Other Ethernet Hub/switch 4

Connection to a Data Manager/Director 4

10/100 Base T connectors 4

Network ID 5

ID for equipment with rotary switches. 5

PR0018-PHI USER GUIDE 6

Front Panel Features (PR0445) 6

Setup via Display 7

Recommended set-up method 8

 Set/View Type 8

 Set/View Parameters (This can also be achieved at the network front end) 8

 ID 8

 Network Configuration 9

 IP-L (Local IP Address) 9

 IP-r (IP Address issued by the DHCP server) 9

Parameters 10

 Parameters Description 12

Input/Output table 13

EEV Control Operation 14

 On board 4-20mA Suction Pressure Input Control Application 14

 Remote Suction Pressure Application 14

Mercury Switch Type 15

 Transducer Connection 15

 MOP – Maximum Operating Pressure 15

Humidity Control Operation 16

 GP Timer Set-up 16

Trim Heater Control via Mercury Case Controller Range 17

Network Alarms 17

Setup via Webpages 18

SPECIFICATION 20

Power requirements: 20

Mounting 20

RS232 Cable Lengths 20

Ethernet Cable lengths 20

REVISION HISTORY 21



Ensure that all power is switched off before installing or maintaining this product

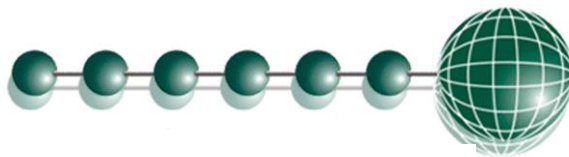

The Mercury Switch

From Resource Data Management

Description

The Mercury Switch (PR0018) is a device that allows up to 10 RDM Mercury controllers to be connected to an IP network, without the need for individual IP Futura modules. There are 10 RS232 connections for linking to 10 Mercury controllers. There are 3 standard Ethernet Switch (10/100baseT) connections for other network devices. The Ethernet ports are self configuring for uplinks and standard 10/100 Base T device connections.

As well as the Switch function there is the option for Island EEV control. This control can be achieved by using a transducer connected to the Mercury Switch 4-20mA input or from a remote Suction pressure reading sent across an IP network from a Mercury Plant Pack controller. Island trim heater control can also be achieved through the display port using a humidity temperature display (PR0445). To utilise either of these features then the PR0018-PHI build option would be required.

Front View



Mains connector

10 x RS232 Ports for direct connection to RDM controllers

Rear View

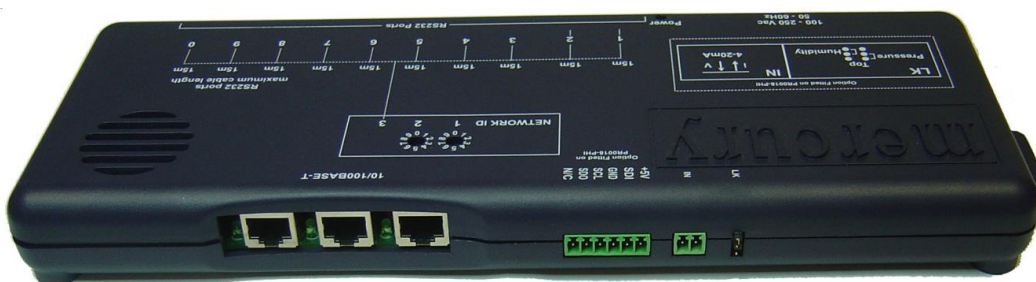

3 x IP ports

Display port

mA Input

mA input selector

Note:- The display port, mA input and mA input selector are fitted on the PR0018-PHI only. The mA input is available for Pressure applications only, for Humidity please use a PR0445 connected to the display port.



Ensure that all power is switched off before installing or maintaining this product

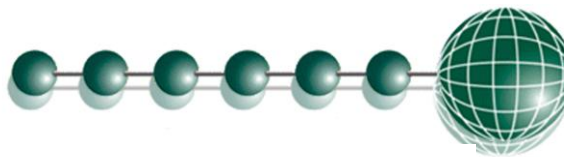

Top View

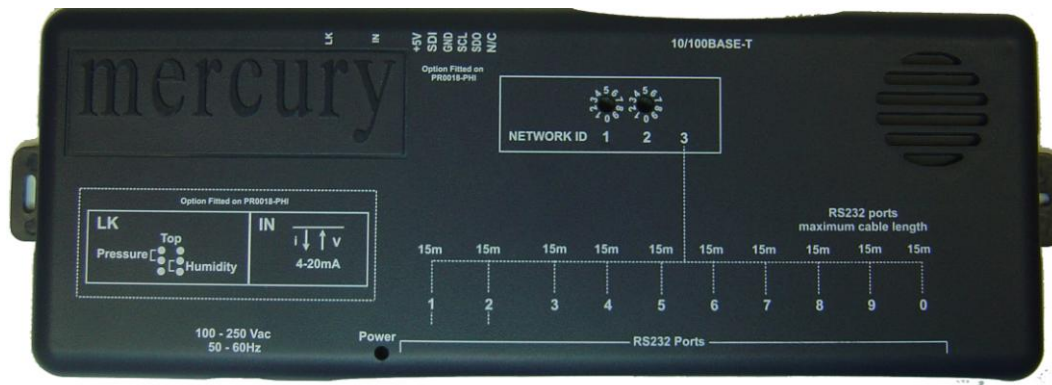

Connection to Mercury Controllers:

Using a standard CAT5 patch lead, connect the serial output of the RDM Controller to one of the RS232 ports of the Mercury Switch.

RS232 Lead Lengths

RS232 patch lead maximum length must not exceed 15 metres. (Ports 1 - 10)

The 3-character address that will be seen on the system front end is determined by the position of the two Network ID rotary switches and the port the controller has been connected to, unless the connected controller has its own network ID rotary switches, in which case the controller ID will override the switch settings.

Connection to other IP equipment

Use a standard CAT5 patch lead to connect other IP equipment to the Mercury Switch (such as a Futura IP module) into the 10/100 Base T ports 1, 2 or 3.

Connection to another Mercury Hub/Switch or Other Ethernet Hub/switch

Use a standard CAT5 patch lead from any of the 3 10/100 Base T ports into any of the 3 10/100 Base T ports on the upstream Mercury Switch. The 3 10/100 Base T ports are all self configuring.

Connection to a Data Manager/Director

Use a standard CAT5 patch lead and connect the Data Manager or Data Director to one of the 3 10 Base T ports.

10/100 Base T connectors

The three 10/100 Base T connectors have 2 LED's adjacent to them: The green LED; when static, indicates that the connection to the device is good, the green LED then flickers when data is being transmitted. When the amber LED is permanently on it indicates that the connection is full duplex and if there is an error or fault on that channel the LED flickers.



Ensure that all power is switched off before installing or maintaining this product

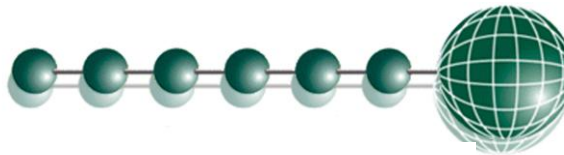

Network ID

The 3-character network ID is made up from the positions of the 2 rotary switches and the RS232 connector number. We recommend that the 2 rotary switches are set to the Bay number and that the case sections are plugged into their corresponding RS232 port numbers.

E.g. Bay 10 case 2:

The 2 rotary switches set to "1" and "0", controller plugged into port 2. The ID then is seen as "102" at the system front end.

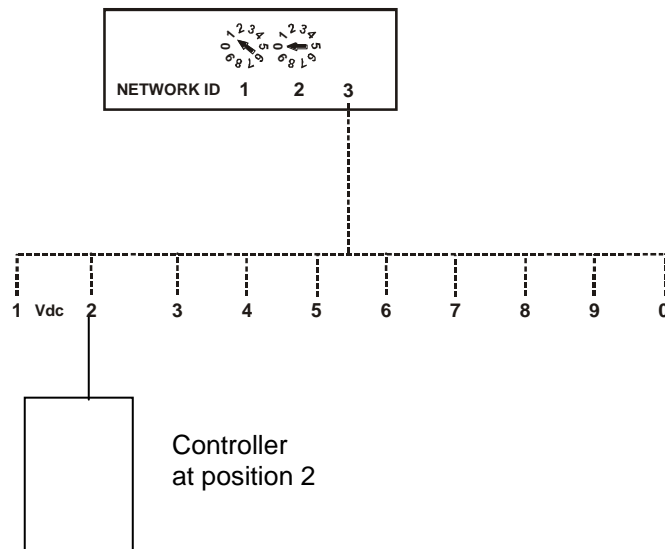

Note that case number 10 would plug into RS232 port 0 (right most port) and come through as "100".

ID for equipment with rotary switches.

For RDM products that use the 3 rotary switches for the network ID (such as Mercury Power tray), the ID will follow what is set on the controller local switches and **NOT** the port position on the Switch.



Ensure that all power is switched off before installing or maintaining this product

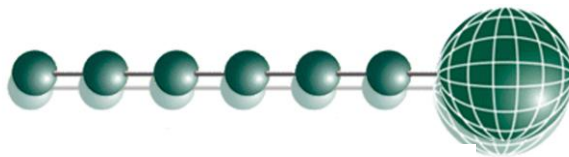

PR0018-PHI User Guide

The PR0018-PHI hardware version of the Mercury Switch allows for EEV Control on an island by island basis. It also allows for the use of the energy feature Trim Control which pulses the trim relay of a Mercury case controller based on the actual shop floor humidity therefore minimising energy usage.

Access to configure the Mercury Switch can be achieved by 2 ways.

- Through the front mounted buttons on the display (PR0445)
- Across an IP network

Front Panel Features (PR0445)

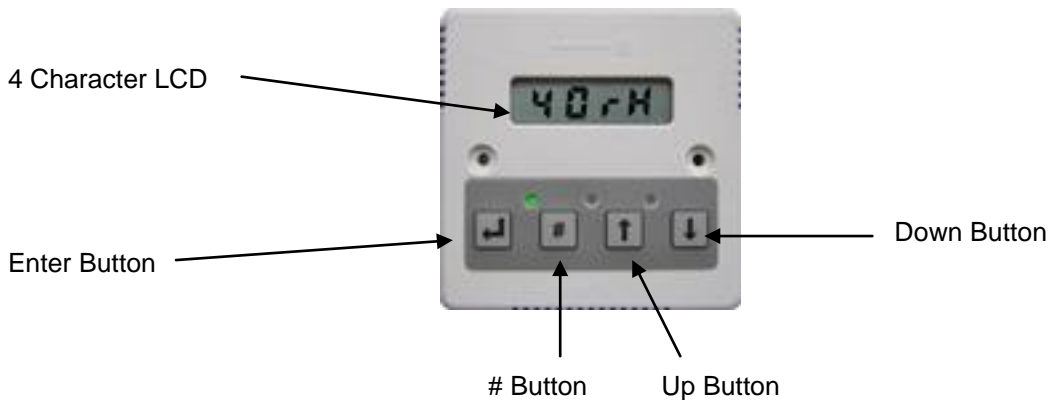

Display: The display fits a standard UK single socket pattress.

Enter Button: Button used to enter/confirm values after a change.

Up Button: When in the software menu, the up button is used to scroll up through the menu items.

Down Button: When in the software menu, the down button is used to scroll down through the menu items

Button: No function

Network LED:

Green LED used to indicate network Status:

- Off No network attached
- Flashing Attempting to Log on to network
- Steady On-line

Amber LED: No function

Alarm LED: Red LED used to indicate an alarm status.



Ensure that all power is switched off before installing or maintaining this product

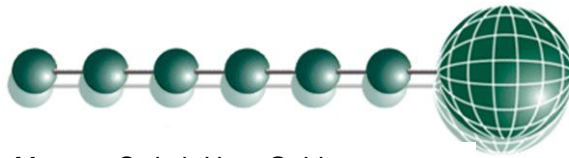

Setup via Display



To enter the software menu for setup mode, hold the **Enter** and **Down** buttons together for approximately 3 seconds until the message “Ent” appears on the display. Release both buttons and now press the Enter button again to enter the software menu. IO is the first item to be displayed. Scroll up or down to go through the menu items which are highlighted below.

Setup Function Menu

Display	Option	Explained in Paragraph
IO	View Input and Output States	IO
PArA	View or change Parameters	PArA
ID	View or change ID	ID
tyPE	View or change Controller Type	type
nEt	View or change the Network Settings	ID
SoFt	View the Software version	
ESC	Escape the menu	



Ensure that all power is switched off before installing or maintaining this product

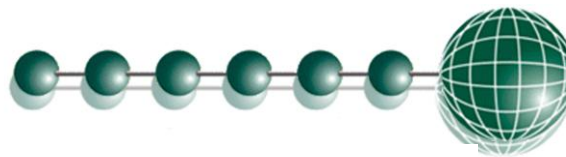

Recommended set-up method

Set/View Type

- a. From the function menu scroll to select type and press enter
- b. The current type is shown. Use the up/down buttons to scroll through the configuration types.
- c. Select the desired number and press enter.

There are 4 types: -

Type	Description
1	Degree C/ Bar
2	Degree C/ PSI
3	Degree F/ Bar
4	Degree F/ PSI

Set/View Parameters (This can also be achieved at the network front end)

- a. From the function menu scroll to select PArA
- b. Pressing Enter while PArA is displayed will enter the parameter menu. The first parameter option will be displayed as P-01. Pressing the Up or Down button will present the other parameter options P-02, P-03 etc. See the parameter table to find what parameter number corresponds to which actual parameter. Pressing the Enter button will show the current value of the selected parameter. Press Up or Down to modify the value and press Enter again to save the value. The parameter list number will be displayed again. Two other options are present in the parameter menu – dFLt and ESC. Selecting ESC will exit setup mode. Selecting dFLt will reset all parameters back to the default values for the current type of controller.

ID

Allows the user to assign a unique three digit software address to the Mercury Switch. Note this is only required when the Mercury Switch is in IP-L mode.

- a. From the function menu scroll to select Id
- b. The current id number will be shown. Use the up/down buttons to scroll through from 000 to 999.
- c. Select the desired number and press enter to save.



Ensure that all power is switched off before installing or maintaining this product

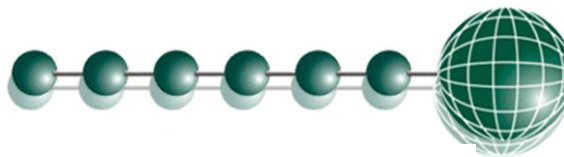

Network Configuration

Unlike the PR0018 (Standard Mercury Switch version) when this product is used with a Data Manager/Data Director it is registered on the system as a device. Once the Mercury Switch is on-line, the Switch type and parameters can be set up. The switch comes online with the ID of the 2 rotary switch settings followed by the letter a. For example with the first rotary switch set to 4 and the second switch set to 8 then the switch would appear as device “48a”. If a DHCP server is present on the IP network set the 2 rotary network switches to an appropriate setting, the Mercury Switch has an auto-initialise function, which will automatically log the device onto the site network. If the wrong ID has been entered onto the network, you will have to reset the Switch ID by setting the ID to 0-0, power cycle and then re-enter the correct ID.

This Switch does not require an external communications module.

IP-L (Local IP Address)

To configure the Mercury Switch for IP-L, set both rotary switches to zero.

1. nEt. From the function menu you can now select nEt
 - Press enter and the display will show “IP-L”, press enter
 - You can now set the address using the table below

Display	Option
IP-1	IP Address byte 1
IP-2	IP Address byte 2
IP-3	IP Address byte 3
IP-4	IP Address byte 4
nL	Network Mask Length
gt-1	Gateway Address byte 1
gt-2	Gateway Address byte 2
gt-3	Gateway Address byte 3
gt-4	Gateway Address byte 4
ESC	Exit network menu. N.B. this option must be selected to save any changes made in this menu

IP-r (IP Address issued by the DHCP server)

To configure the Mercury Switch for IP-r, set the two rotary switches to give each controller a unique identifier. The controller should then be connected to the network.

2. nEt. From the function menu you can now select nEt
 - Press enter and the display will show “IP-r”, press enter
 - You can now view only the address given by the DHCP server

To ease setup, a single network mask length value is used. If the address has been specified with a network mask value in dotted IP format e.g. 255.255.255.0 then the table below gives the conversion:

Mask	Length	Mask	Length	Mask	Length
		255.255.254.0	23	255.254.0.0	15
255.255.255.252	30	255.255.252.0	22	255.252.0.0	14
255.255.255.248	29	255.255.248.0	21	255.248.0.0	13
255.255.255.240	28	255.255.240.0	20	255.240.0.0	12
255.255.255.224	27	255.255.224.0	19	255.224.0.0	11
255.255.255.192	26	255.255.192.0	18	255.192.0.0	10
255.255.255.128	25	255.255.128.0	17	255.128.0.0	09
255.255.255.0	24	255.255.0.0	16	255.0.0.0	08



Ensure that all power is switched off before installing or maintaining this product

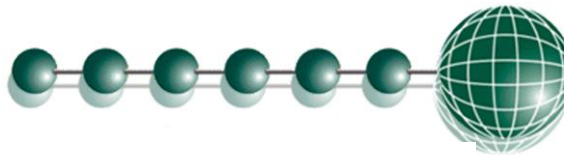

Parameters

	Parameter	Range Bar (psi)	Step	Units	Default Bar (Psi)	
P-01	Refrigerant	None (0) R12 (1) R13 (2) R13b1 (3) R22 (4) R23 (5) R32 (6) R114 (7) R134a (8) R142B (9) R227 (10) R401 (11) R401A (12) R401B (13) R402 (14) R402A (15) R402B (16) R404A (17) R407A (18) R407B (19) R407C (20) R500 (21) R502 (22) R503 (23) R507 (24) R717 (25) R290 (Propane) (26) R744 (27)			N/A	None
P-02	Span	-3.4 to 150.0 (-49.3 to 2175)	0.1	Bar (Psi)	13.8 (200)	
P-03	Offset	-3.4 to 150.0 (-49.3 to 2175)	0.1	Bar (Psi)	0.0 (0.0)	
P-04	Glide	0 to 5	0.1	°C	0.0	
P-05	Pressure Type	Absolute (0), Gauge (1)	1		Absolute	
P-11	Evap 1 offset	0.0 to 0.5 (0 to 7.2)	0.1	Bar (Psi)	0.1	
P-12	Evap 2 offset	0.0 to 0.5 (0 to 7.2)	0.1	Bar (Psi)	0.1	
P-13	Evap 3 offset	0.0 to 0.5 (0 to 7.2)	0.1	Bar (Psi)	0.1	
P-14	Evap 4 offset	0.0 to 0.5 (0 to 7.2)	0.1	Bar (Psi)	0.1	
P-15	Evap 5 offset	0.0 to 0.5 (0 to 7.2)	0.1	Bar (Psi)	0.1	
P-16	Evap 6 offset	0.0 to 0.5 (0 to 7.2)	0.1	Bar (Psi)	0.1	
P-17	Evap 7 offset	0.0 to 0.5 (0 to 7.2)	0.1	Bar (Psi)	0.1	
P-18	Evap 8 offset	0.0 to 0.5 (0 to 7.2)	0.1	Bar (Psi)	0.1	
P-19	Evap 9 offset	0.0 to 0.5 (0 to 7.2)	0.1	Bar (Psi)	0.1	
P-20	Evap 10 offset	0.0 to 0.5 (0 to 7.2)	0.1	Bar/Psi	0.1	
P-31	Transducer Fault Delay	00:00 to 99:00	01:00	Mins	01:00	
P-32	Alarm Delay	00:00 to 99:00	01:00	Mins	01:00	
P-33	HP Alarm	-3.4 to 150.0 (-49.3 to 2175)	0.1	Bar (Psi)	4.0 (58.0)	
P-40	MOP	-3.4 to 150.0 (-49.3 to 2175)	0.1	Bar (Psi)	3.4 (50.0)	
P-41	MOP Diff	-3.4 to 150.0 (-49.3 to 2175)	0.1	Bar (Psi)	0.3 (5.0)	
P-42	MOP Delay	00:00 to 02:00	00:01	min : sec	00:05	
P-43	Recovery Count	0 – 10	1		2	
P-50	Humidity Low	0-100	1	rH	20	
P-51	Humidity High	0-100	1	rH	60	



Ensure that all power is switched off before installing or maintaining this product

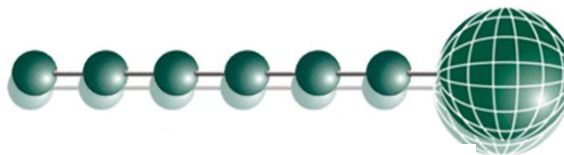

Mercury Switch User Guide

P-52	Trim Low	0-100	1	%	30
P-53	Trim High	0-100	1	%	100
P-54	Trim Off Level	0-100	1	%	30
P-55	Trim Mode	0 = Off 1 = On 2 = Remote	1		On
P-56	Broadcast ID	0 - 999	1		0
P-57	Evaporator Type	0 = Local 1 = Remote 1 2 = Remote 2 3 = Remote 3	1		0

* Span and Offset allows for the full range of the transducer to be used by the Mercury Switch.
Span is the full range of the transducer

Offset is the value below zero.

An example Transducer setup is: - Danfoss AKS 33 with range: -1 Bar to 12 Bar

Span would be 190 (13 Bar)
Offset would be -15 (-1 Bar)



Ensure that all power is switched off before installing or maintaining this product

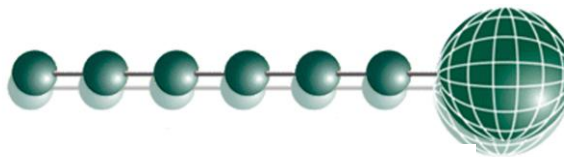

Parameters Description

Number	Parameter	Description
P-01	Refrigerant	Select the gas type used within the refrigeration system.
P-02	Span	Total range of transducer*
P-03	Offset	Value below zero*
P-04	Glide	Glide characteristic (Offset to Evap Temperature)
P-05	Pressure Type	Select between Absolute or Gauge pressure
P-11	Evap 1 offset	Pressure difference between suction transducer and evaporator 1
P-12	Evap 2 offset	Pressure difference between suction transducer and evaporator 2
P-13	Evap 3 offset	Pressure difference between suction transducer and evaporator 3
P-14	Evap 4 offset	Pressure difference between suction transducer and evaporator 4
P-15	Evap 5 offset	Pressure difference between suction transducer and evaporator 5
P-16	Evap 6 offset	Pressure difference between suction transducer and evaporator 6
P-17	Evap 7 offset	Pressure difference between suction transducer and evaporator 7
P-18	Evap 8 offset	Pressure difference between suction transducer and evaporator 8
P-19	Evap 9 offset	Pressure difference between suction transducer and evaporator 9
P-20	Evap 10 offset	Pressure difference between suction transducer and evaporator 10
P-31	Transducer Fault Delay	Alarm generated, once transducer fault delay expires, if the transducer fails.
P-32	Alarm Delay	Delay before the HP alarm is generated.
P-33	HP Alarm	If the pressure exceeds this value then a High Pressure alarm is generated once the alarm delay expires.
P-40	MOP	If the pressure exceeds this value the valves on controllers connected to the Mercury Switch will closed or be reduced to a predetermined percentage. A MOP alarm is also created. (See MOP)
P-41	MOP Diff	When the pressure reduces below this value valves on controllers connected to the Switch will recover to their normal operational
P-42	MOP Delay	Delay after the MOP value has been exceeded before the MOP actions and alarm occurs.
P-43	Recovery Count	When the Switch comes out of MOP, the valves will come on at 1 minute intervals and turn "this" number of valves on per minute.
P-50	Humidity Low	Sets humidity low level.
P-51	Humidity High	Sets humidity high level.
P-52	Trim Low	Sets trim low level.
P-53	Trim High	Sets trim high level.
P-54	Trim Off Level	When the timer is in the off period the trims will be pulsed at this value. Note if the humidity sensor fails the trim relays will be pulsed at this level.
P-55	Trim Mode	<ul style="list-style-type: none"> ➤ Off – Pulses the controller trim relays at the Trim Off Level. ➤ On – trim control feature will continuously pulse the controller trim relays dependant on the measured humidity. ➤ Remote – Uses Data Manager GP Timer channel to determine when to control. See GP Timer Setup
P-56	Broadcast ID	ID of Plant Controller being used to broadcast Suction Pressure The Broadcast ID is derived from the Rotary Switch positions set on the Plant controller which is providing the remote suction pressure. Note: no two Plant controllers on a local area network can have the same rotary switches positions set. This will have adverse affects on control.
P-57	Evaporator Type	Select one of the following to determine the source of the pressure value used to calculate the remote evaporator temperature. <ul style="list-style-type: none"> ➤ Local – Uses Mercury Switch on board 4-20mA Input ➤ Remote 1 – Uses the Remote Plant controllers Transducer Input 1 ➤ Remote 2 – Uses the Remote Plant controllers Transducer Input 2 ➤ Remote 3 – Uses the Remote Plant controllers Transducer Input 3 Note: Mercury Switch pressure units must match that of the Plant Pack controller it is mapped to e.g. both devices have to be set to Bar or PSI



Ensure that all power is switched off before installing or maintaining this product

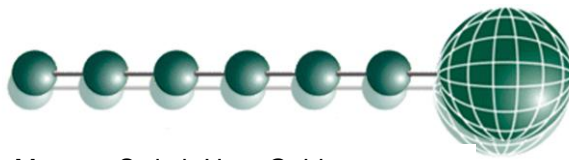

Input/Output table

Number	IO	Range	Units
I-01	Evap Press	-3.4 to 150.0 (-49.3 to 2175)	Bar (Psi)
I-02	Evap 1 Press	-3.4 to 150.0 (-49.3 to 2175)	Bar (Psi)
I-03	Evap 2 Press	-3.4 to 150.0 (-49.3 to 2175)	Bar (Psi)
I-04	Evap 3 Press	-3.4 to 150.0 (-49.3 to 2175)	Bar (Psi)
I-05	Evap 4 Press	-3.4 to 150.0 (-49.3 to 2175)	Bar (Psi)
I-06	Evap 5 Press	-3.4 to 150.0 (-49.3 to 2175)	Bar (Psi)
I-07	Evap 6 Press	-3.4 to 150.0 (-49.3 to 2175)	Bar (Psi)
I-08	Evap 7 Press	-3.4 to 150.0 (-49.3 to 2175)	Bar (Psi)
I-09	Evap 8 Press	-3.4 to 150.0 (-49.3 to 2175)	Bar (Psi)
I-10	Evap 9 Press	-3.4 to 150.0 (-49.3 to 2175)	Bar (Psi)
I-11	Evap 10 Press	-3.4 to 150.0 (-49.3 to 2175)	Bar (Psi)
I-12	Humidity	0 to 100	rH
I-13	Sensor Temp	-49.0 to 60 (-56.2 to 140.0)	°C (°F)
I-14	Remote 1 Pressure	-3.4 to 150.0 (-49.3 to 2175)	Bar (Psi)
I-15	Remote 1 Pressure	-3.4 to 150.0 (-49.3 to 2175)	Bar (Psi)
I-16	Remote 1 Pressure	-3.4 to 150.0 (-49.3 to 2175)	Bar (Psi)
O-01	Evap Temp	-49.0 to 60 (-56.2 to 140.0)	°C (°F)
O-02	Evap 1 Temp	-49.0 to 60 (-56.2 to 140.0)	°C (°F)
O-03	Evap 2 Temp	-49.0 to 60 (-56.2 to 140.0)	°C (°F)
O-04	Evap 3 Temp	-49.0 to 60 (-56.2 to 140.0)	°C (°F)
O-05	Evap 4 Temp	-49.0 to 60 (-56.2 to 140.0)	°C (°F)
O-06	Evap 5 Temp	-49.0 to 60 (-56.2 to 140.0)	°C (°F)
O-07	Evap 6 Temp	-49.0 to 60 (-56.2 to 140.0)	°C (°F)
O-08	Evap 7 Temp	-49.0 to 60 (-56.2 to 140.0)	°C (°F)
O-09	Evap 8 Temp	-49.0 to 60 (-56.2 to 140.0)	°C (°F)
O-10	Evap 9 Temp	-49.0 to 60 (-56.2 to 140.0)	°C (°F)
O-11	Evap 10 Temp	-49.0 to 60 (-56.2 to 140.0)	°C (°F)
O-21	MOP	Off (0) or On (1)	
O-31	Trim Level	0 to 100 %	%
O-32	Remote Trim	Off (0) or On (1)	
O-33	Remote 1 Temperature	-49.0 to 60 (-56.2 to 140.0)	°C (°F)
O-34	Remote 2 Temperature	-49.0 to 60 (-56.2 to 140.0)	°C (°F)
O-35	Remote 3 Temperature	-49.0 to 60 (-56.2 to 140.0)	°C (°F)



Ensure that all power is switched off before installing or maintaining this product

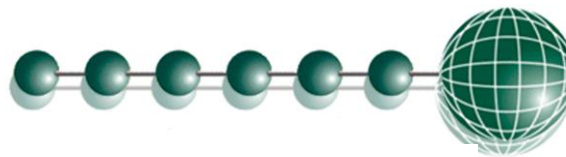

EEV Control Operation

Product PR0018-PHI is intended for EEV control on an Island by island basis and can be implemented in two ways.

1. Using the on board 4-20mA Input to measure the suction pressure going to the island.
2. Using a remote suction pressure sent from Mercury Plant Controller (PR0600-PACK) on the same IP network. Note this remote pressure can be shared by more than one Mercury Switch.

On board 4-20mA Suction Pressure Input Control Application

- Ensure parameter 57 is set to “Local”.
- Configure the remaining parameters.
- Connect the suction pressure transducer for the Island to the 4-20mA input on the Mercury Switch.
- Ensure the transducer is correctly connected and the mA input selector jumper is in the Pressure position.
- Ensure each Mercury case controller has been configured to accept the calculated remote evaporator temperature. See Mercury user guide for further details.

Remote Suction Pressure Application

- Ensure parameter 57, Evaporator Type, is set to Remote 1 or Remote 2 or Remote 3.
- Set parameter 56, Broadcast ID, to match the ID of the desired Plant Pack Controller.
- Configure the remaining parameters.
- Configure the desired Plant Pack controller to broadcast the Suction pressure. See RDM Plant Controller PR0600 for further information on how to broadcast pressure.

Note

If the Plant Controller being read from is set to Bar then the Mercury Switch has to be set for Bar (Type 1 or 3)

If the Plant Controller being read from is set to PSI then the Mercury Switch has to be set for PSI (Type 2 or 4).

Operation

Once the Switch has been correctly setup, it will pass values to each of the controllers connected to ports 1 through 10. In an EEV application the evaporator in temperature probe reading for a case controller can be obtained from the Mercury Switch on which the controller is connected. A suction pressure transducer is connected from the case Island to the 4-20mA input of the Mercury Switch or the pressure read from a remote plant controller. This pressure is then converted to a temperature based on the gas type being used by the system. This temperature is transmitted to each controller connected to the switch and along with the suction temperature probe local to the controller the superheat is calculated. Please see the Mercury Case controller user document from the RDM website for further details. (P-51 Minimum valve opening) RDM recommend that this parameter be set to 0% when using Mercury Pressure Switch to calculate Superheat. Please note that RDM recommend that the evaporator in temperature probe is fitted as the controller will use this to calculate the superheat in the event of a communication loss with the Mercury Switch. (Or the remote Mercury Plant Controller) The Mercury Case controllers require to have P17 (Evaporator control) set to 1 (Remote) for this feature to function.



Ensure that all power is switched off before installing or maintaining this product

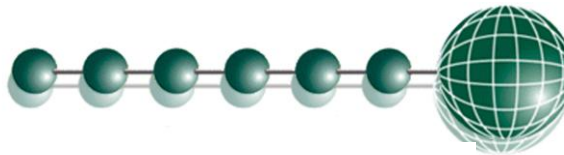

Mercury Switch Type

There are 4 types: -

Type	Description
1	Degree C/ Bar
2	Degree C/ PSI
3	Degree F/ Bar
4	Degree F/ PSI

Transducer Connection

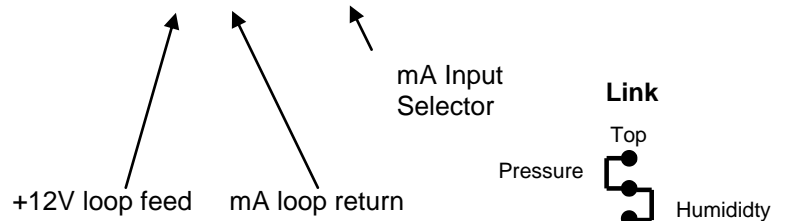

MOP – Maximum Operating Pressure

When the MOP alarm is created a valve off command is sent to the 6-5E controllers connected to the Mercury Switch. The percentage that the valve shuts down to is dependent on the “Div Value” parameter in the Mercury case controller. When the Mercury Switch generates the MOP alarm the controller reduces the maximum valve opening to this percentage. For example if the “Div Value” parameter is set to 50% and the MOP alarm is generated then the maximum valve opening will be limited to 50%. Therefore as the controller pulses the valve the maximum the valve will open to is 50%.

If Mercury 6-5M controllers are connected to the Switch then the LLV will be closed when the MOP alarm is created and return to normal operation when the alarm clears. When the pressure reduces below the MOP diff the valves will revert to normal operation at 1 minute intervals. The number of controller coming back to normal operation per minute depends on the “recovery count” value.



Ensure that all power is switched off before installing or maintaining this product

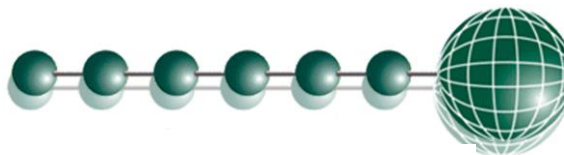

Humidity Control Operation

To utilise this feature a Humidity/Temperature Display is required (PR0445). Connect the Humidity/Temperature display to the display port on the Mercury Switch. The control algorithm will use the humidity reading from the display in calculating the percentage at which the trim relays are to be pulsed.

When the measured rH is below the “Humidity Low” parameter the Mercury Switch will pulse the Mercury case controller trim relays to the duration set by the “Trim Low” parameter. When the measured rH is above the “Humidity Low” parameter but below the “Humidity High” parameter the Mercury Switch will pulse the Mercury case controller trim relays in proportion to the line drawn between the low and high levels. When rH goes above the “Humidity High” level the Mercury Switch will pulse the Mercury case controller trim relays at the “Trim High” setting. Setting the trim high parameter to 70% will result in 30 % energy savings as the controller trim relays will never pulse on for more than 70%. The trims are pulsed over a 5 minute period. Therefore if the Mercury Switch calculates the trim percentage as 50% then the trim relay will be on for 2 and a half minutes and then off for 2 and a half minutes.

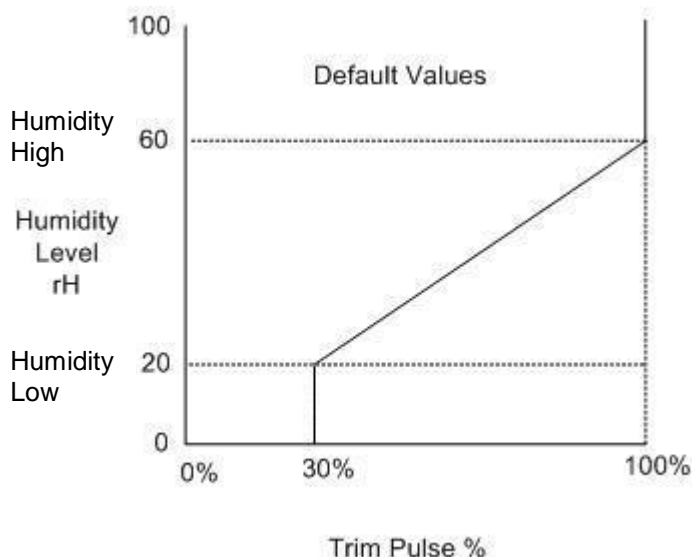

GP Timer Set-up

It is possible to set the Mercury Switch humidity control to operate at specific times. For this operation to occur set the parameter “Trim Mode” to “Remote”. A GP Timer channel must be set up to control the timer on/off periods of the Mercury Switch. For GP Timer set up please refer to the Data Manager user guide found on the RDM website. The following settings should be followed in the GP setup.

- Output Type – This should be set to “General”.
- Output Mask – This should match the “Controller Name” e.g. “45a”
- Output Channel – Set to “13”. This will allow the GP Timer to control the state of the timer.

When the parameter “Trim Mode” is set to “Remote” and the Data Manager GP timer channel directed to the Mercury Switch is in the on period the humidity control will operate as described above. During the Data Manager GP timer channel off period the relay will pulse to the preset “Trim Off Level” parameter. For example if the trim off level is zero then the trims will be completely off. Thus allowing the user to save energy when the store isn’t trading and the trims are not required.

Note if you wish the Mercury controller trim relay to follow the Data Manager Trim Control feature and not the Mercury Switch settings then please see the Mercury Controller user document (Parameter P-12).



Ensure that all power is switched off before installing or maintaining this product

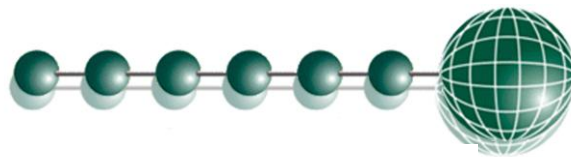

Trim Heater Control via Mercury Case Controller Range

Energy savings via the Mercury controller range can be achieved in a number of ways. One of which is pulsing the trim heater relay off for a given period of time. One way to pulse the trim heater relay in the Mercury case controller range is by setting the parameter "Trim Level". This sets a percentage level, of a 5-minute period, to pulse the trim heater relay off/on. Using this parameter pulses the trim relay irrespective of the actual shop floor humidity. For greater energy savings the Data Manager energy feature trim control or the Mercury Switch trim control feature can be used. These two options pulse the trim relay dependant on the actual shop floor humidity levels. Thus if the shop floor humidity is relatively low the trim heaters can be pulsed off for longer durations. Please see the relevant user guides for further details.

RDM recommend that the trim heater pulse module is used in all instances (PR0723). This module is fitted in between the trim heater of the case and the relay output of the Mercury Controller which is pulsing the heater. The trim heater module output provides a smoother power distribution, compared to using the relay output direct, as it switches at the zero voltage crossover point. Switching the trim heater on and off via a normal relay, without using the RDM trim heater pulse module, may damage the trim heater and reduce the operational life of the heater. Therefore RDM recommend the use of this module in every trim heater control application.

Network Alarms

The table below shows the text and associated type number that is sent to the system "front end". The type number is normally used to provide different alarm actions.

Alarm text	Type # (Index)
Transducer Fault	6
High Pressure Alarm	8
MOP Alarm	3



Ensure that all power is switched off before installing or maintaining this product

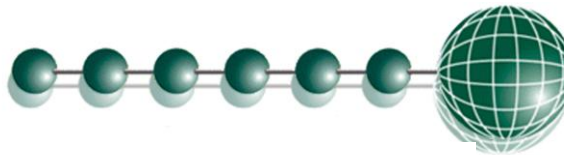

Setup via Webpages

The Mercury Switch can be configured by navigating to the Mercury Switch WebPages. This can be achieved by using the Controller Info page in the Data Manager/Data Director. Find the IP address assigned to the Mercury Switch in question from the list. Now connect a laptop onto the IP network on which the Mercury Switch is connected. Using a web browser navigate to the IP address of the Mercury Switch. The homepage of the Mercury Switch is shown below: -

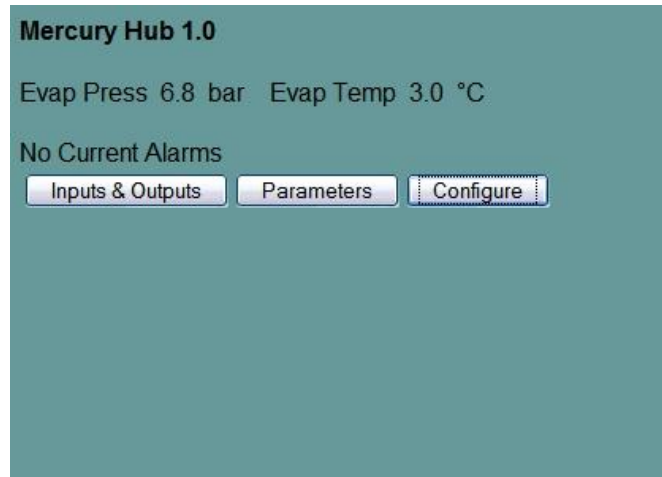

Click on "Configure" to set the type: -

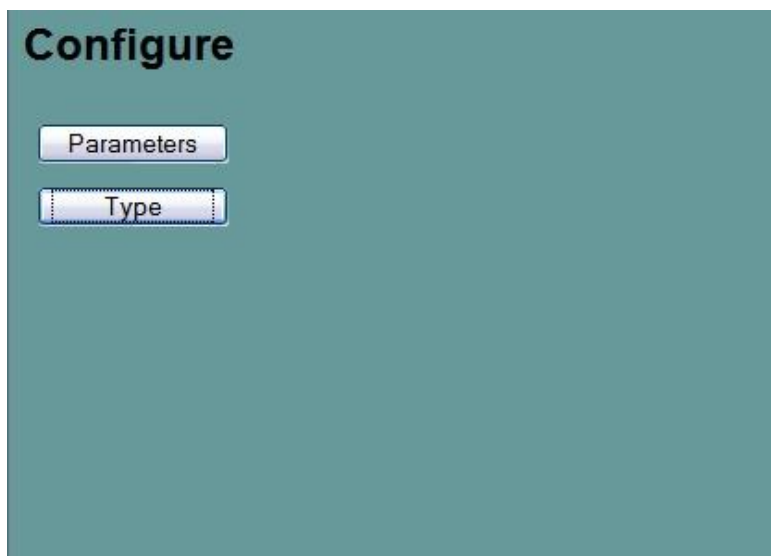

Ensure that all power is switched off before installing or maintaining this product

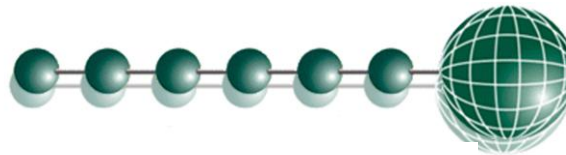

Then click “Type”

Set Type

Mercury Hub degC/bar ▼

Set Type

Use the drop-down selection to select the type required and then click “Set Type”

Parameters can be changed using the connection as illustrated above or through the normal Data Manager/Director change parameter routes or through the display if fitted (PR0445).



Ensure that all power is switched off before installing or maintaining this product

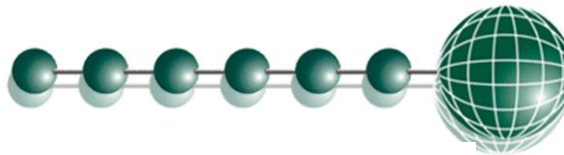

Specification

Power requirements:

Supply Voltage Range:	100 – 240 Vac \pm 10% (Mains version)
Supply Frequency:	50 – 60 Hz (Mains version)
Typical supply current:	<500 mAmps
Maximum supply current	650mA
Operating temperature range:	+5 ⁰ C to +50 ⁰ C
Operating Humidity:	80% maximum
Storage temperature range:	-20 ⁰ C to +65 ⁰ C
Environmental:	Indoor use at altitudes up to 2000m, Pollution Degree 1, Installation Category II. Voltage fluctuations not to exceed \pm 10% of nominal voltage
Size:	300mm (L) x 35mm (H) x 110mm (W)
Weight:	300 Grams
Safety:	EN61010
EMC:	EN61326; 1997 +Amdt. A1; 1998
Ventilation:	There is no requirement for forced cooling ventilation
Class 2 Insulation:	No protective Earth is required and none should be fitted.

The host equipment must provide a suitable external over-current protection device such as: -

Fuse:	1A 240 Vac Antisurge (T) HRC conforming to IEC 60127
Or MCB:	1A, 240 VAC Type C conforming to BS EN 60898

Mounting

There is a fixing lug at each end of the Switch, with hole centres 317 mm apart. Use typically Number 6 x 1” Pan head screw with 6mm washer, torque down to 1.5 Newton metres.

RS232 Cable Lengths

All RS232 connections must not exceed 15 metres/connection.

Ethernet Cable lengths

Port number	Main Powered Switch
1	Refer to Cat5 standard
2	Refer to Cat5 standard
3	Refer to Cat5 standard



Ensure that all power is switched off before installing or maintaining this product

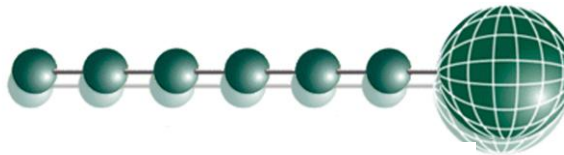

Revision History

Revision	Date	Changes	Comments
1.6	01/03/2009	1 st released copy. Revision history brought into line with Mercury Switch software version.	
1.7	01/05/2009	Support added for PR0445 display to allow setting of parameters, type and so forth.	
1.7a	29/06/2009	Changed Evap probe offset default value.	
1.7b	24/09/2009	Update to 10/100 Base T connection description.	
1.7c	18/12/2009	Fitting instructions for mA input selector included.	
1.8	29/04/2010	Range of transducer increased to 150 Bar Remote suction pressure from Plant Controller feature introduced.	



Ensure that all power is switched off before installing or maintaining this product