

# Mercury Power Tray Installation Guide

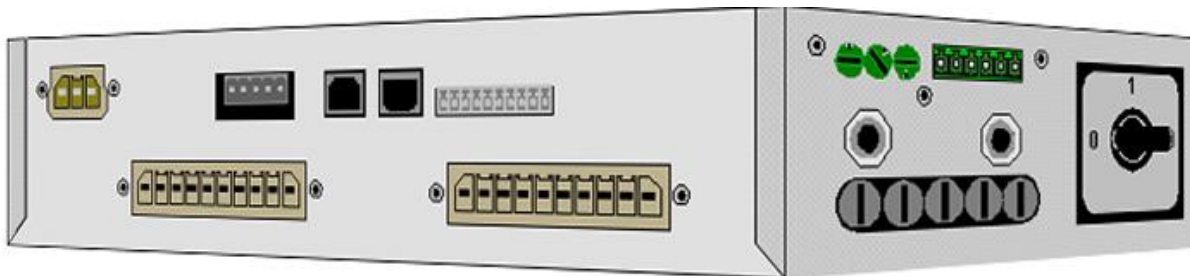

**PR0040, PR0041, PR0042  
PR0043, PR0044, PR0045  
PR0046, PR0047, PR0048  
PR0049, PR0050, PR0051  
PR0052, PR0053**



Authorised User No. 00181



Ensure that all power is switched off before installing or maintaining this product

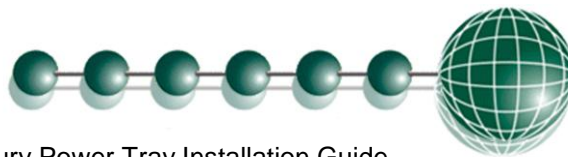

**Table of Contents:**

**THE MERCURY RANGE ..... 4**

**Types ..... 4**

**Configuration ..... 4**

**Networks..... 4**

**Remote Display Features..... 5**

    Display: ..... 5

    Enter Button: ..... 5

    Up Button: ..... 5

    Down Button:..... 5

    Defrost Button: ..... 5

    Network LED: ..... 5

    Defrost LED:..... 5

    Fault LED: ..... 5

**Connections ..... 6**

    Mains Connections: - ..... 6

    Primary Functions Connections ..... 6

    Secondary Functions Connections ..... 6

    Signal Connections ..... 7

    Probe Connections..... 7

    Network Connections; RS485 ..... 7

    Network Connections; IP ..... 7

    Remote Display Connection ..... 8

**Network Address Switches ..... 8**

**Input/Output Allocation Tables ..... 9**

    Input / Output allocation tables for the 6-5M ..... 9

    Input / Output allocation tables for 6-5E..... 9

**Setting up the controller ..... 10**

    Setup Mode..... 10

    Setup through front buttons ..... 10

    Setup Function Menu ..... 10

**Recommended set-up method ..... 11**

    rtc. Real time clock (This will automatically synchronise on network systems) ..... 11

    type. Set/view controller type ..... 11

    PArA. Set/view parameters (This can be achieved at the network front end) ..... 12

    Unit. Set/view temperature unit and Probe type ..... 12

    Probe Types ..... 12

**Parameter Tables:..... 13**

    Parameter table for type M ..... 13

    Parameter table for type E ..... 15

**Parameter Description : ..... 17**

    P90 Note: ..... 19

**EEV Control Using Pressure ..... 20**

**Maximum Operating Pressure (MOP)..... 20**

**Relay and screen states during defrost ..... 20**

**Defrost Termination..... 20**

**Fan Delay after Defrost ..... 21**

**Network Configuration ..... 22**

    485 Legacy module..... 22

    Fast Network Address Reset ..... 23

    IP Futura module..... 23

        IP-L ..... 23

        IP-r ..... 24

**Viewing ..... 25**

    Input/Output table for Case Controller M ..... 25

    Input/Output table for Case Controller E ..... 26

**Alarm Messages ..... 27**



Ensure that all power is switched off before installing or maintaining this product

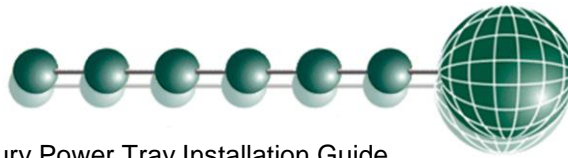

## Mercury Power Tray Installation Guide

<b>Network Alarms</b> .....	<b>27</b>
<b>Modifying controller states</b> .....	<b>28</b>
Defrost “dEF” .....	28
Fans Only “FAnS” .....	28
Case Off “CASE” .....	28
Lights Only “LitS” .....	28
<b>Remote Commands:</b> .....	<b>29</b>
<b>Plant Input Resistors:</b> .....	<b>30</b>
<b>Specification</b> .....	<b>31</b>
Power requirements: .....	31
Inputs: .....	31
Output ratings and fuses .....	32
<b>Mating Connectors</b> .....	<b>33</b>



Ensure that all power is switched off before installing or maintaining this product

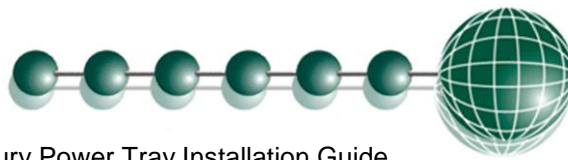

## The Mercury Range

### From Resource Data Management

#### Types

**This documentation refers to the 6 input Power Tray with Mercury 6-5 M/E controller With Software Version 10.1**

There are eight hardware types for the Power Tray: -

- |  |        |
|--|--------|
| 1. Power Tray Full Cycle Defrost, Mercury 6-5M and RS485 communications module           | PR0040 |
| 2. Power Tray Full Cycle Defrost, Mercury 6-5E and RS485 communications module           | PR0041 |
| 3. Power Tray Full Cycle Defrost, Mercury 6-5M and IP communications module              | PR0042 |
| 4. Power Tray Full Cycle Defrost, Mercury 6-5E and IP communications module              | PR0043 |
| 5. Power Tray Off Cycle Defrost, Mercury 6-5M and RS485 communications module            | PR0044 |
| 6. Power Tray Off Cycle Defrost, Mercury 6-5E and RS485 communications module            | PR0045 |
| 7. Power Tray Off Cycle Defrost, Mercury 6-5M and IP communications module               | PR0046 |
| 8. Power Tray Off Cycle Defrost, Mercury 6-5E and IP communications module               | PR0047 |
| 9. Power Tray Off Cycle Defrost, Mercury 6-5E no communications module, with filter      | PR0048 |
| 10. Power Tray Off Cycle Defrost, Mercury 6-5E and IP communications module, with filter | PR0049 |
| 11. Power Tray Full Cycle Defrost, Mercury 6-5M no communications module                 | PR0050 |
| 12. Power Tray Full Cycle Defrost, Mercury 6-5E no communications module                 | PR0051 |
| 13. Power Tray Off Cycle Defrost, Mercury 6-5M no communications module                  | PR0052 |
| 14. Power Tray Off Cycle Defrost, Mercury 6-5E no communications module                  | PR0053 |

#### Configuration

The Trays are delivered pre-configured as HT Case controllers; Type 4

The controller within the tray gives 2 configuration options, LT and HT: -

Display value	Type MT	Type ET
1	Do Not Use	N/A
2	Do Not Use	N/A
3	Remote case controller LT	Remote case controller LT
4	Remote case controller HT	Remote case controller HT
5	Do Not Use	Do Not Use
6	Do Not Use	Do Not Use

#### Networks

The Power Tray is capable of connecting to either a TCP/IP local area network or a RS485 network or controlling in standalone mode.

To connect to a network you must choose the correct configuration

- 485 models
- IP models



Ensure that all power is switched off before installing or maintaining this product

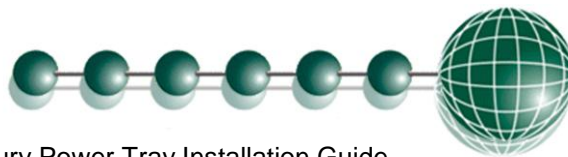

## Remote Display Features

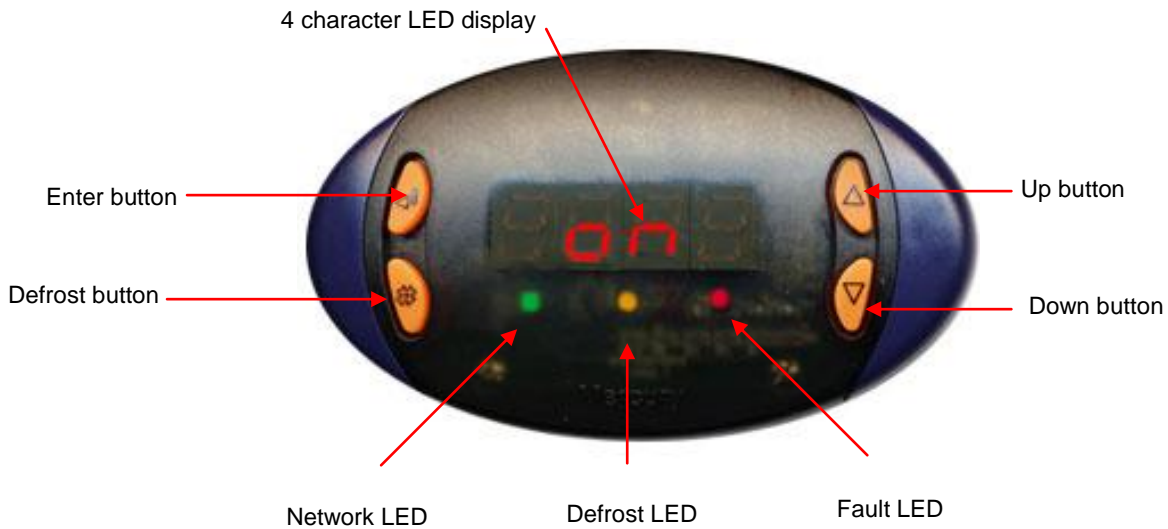

### Display:

4 character red LED display, used to display temperature and status messages.

### Enter Button:

Button used to enter values front the menu system.

### Up Button:

Button used to scroll up through the menu items

### Down Button:

Button used to scroll down through the menu items

### Defrost Button:

Press and hold this button to force a manual defrost

### Network LED:

Green LED used to indicate network Status:

- Off No network attached
- Flashing Attempting to Log on to network
- Steady On-line

### Defrost LED:

Yellow LED, used to indicate defrost status

### Fault LED:

Red LED, used to indicate alarm status

**Note** the controller is not supplied with a display.



Ensure that all power is switched off before installing or maintaining this product

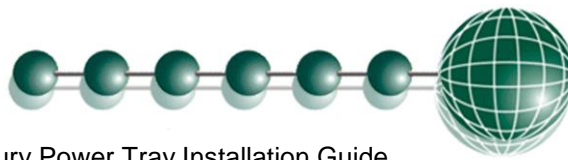

**Connections**

**Mains Connections: -**

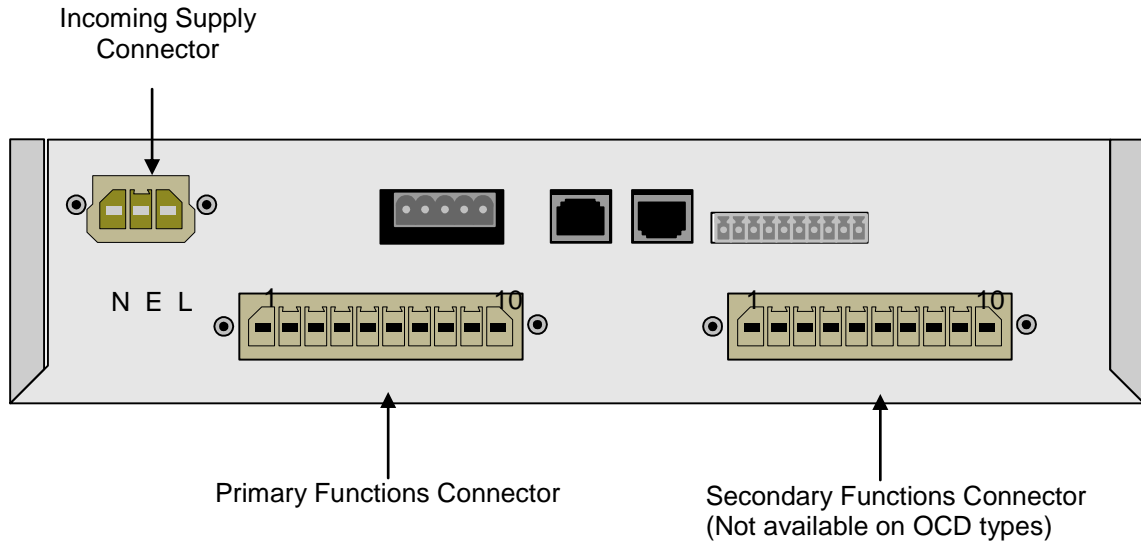

**Primary Functions Connections**

Pin Number	Function	Comments
1	Earth	
2	Defrost Live*	18 Amps with integrated trip
3	Defrost Neutral	
4	LLV Live	1 Amp with integrated fuse
5	LLV Neutral	
6	Fans Live	2 Amps with integrated fuse
7	Fans Neutral	
8	Lights Live	5 Amps with integrated fuse
9	Lights Neutral	
10	Earth	

\* This output carries the Gas Valve function on OCD types

**Secondary Functions Connections**

Pin Number	Function	Comments
1	Earth	
2	Suction Valve Live	2 Amps with integrated fuse
3	Suction Valve Neutral	
4	Gas Valve Live	1 Amp with integrated fuse
5	Gas Valve Neutral	
6	Not used	
7	Neutral	
8	Trim Heater Live	7 Amps with integrated trip
9	Trim Heater Neutral	
10	Earth	



Ensure that all power is switched off before installing or maintaining this product

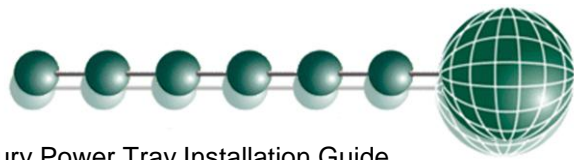

**Signal Connections**

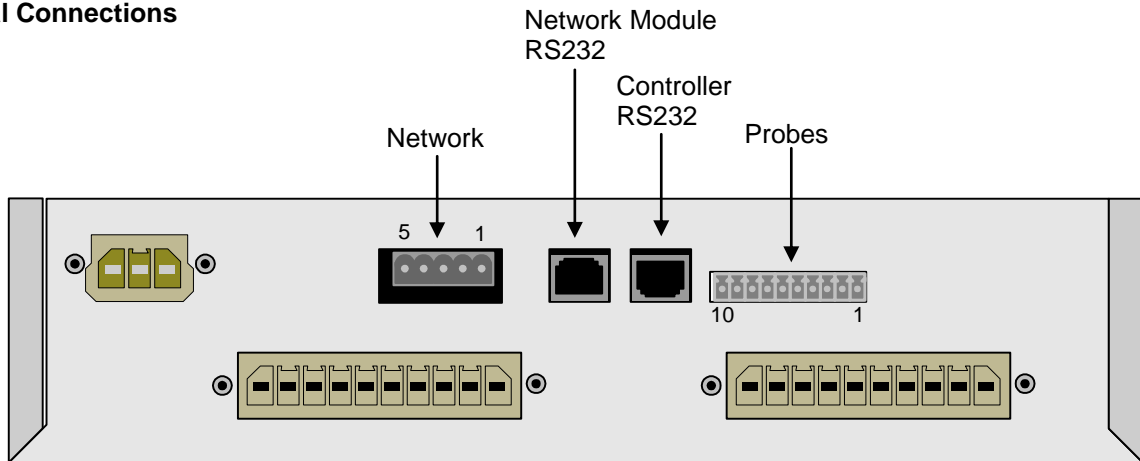

**Probe Connections**

Pin Number	All Models	Comments
1	Probes common	
2	Air on Probe	
3	Air off Probe	
4	Probes common	
5	Evaporator Probe	
6	Suction Line Probe	
7	Probes common	
8	Defrost Termination Probe	
9	Logging Probe	
10	Probes common	

**Network Connections; RS485**

Pin Number	RS485 shown on diagram	Comments
1	Screen	Do not connect
2	A or data+	Red
3	Common	White
4	B or data -	Black
5	Common	Green

**Network Connections; IP**

Pin Number	IP (CAT 5) not shown on diagram	Comments
1	TP out+	Use CAT 5 (1 to 1)
2	TP out-	
3	TP In+	
4	Not Used	
5	Not Used	
6	TP In-	
7	Not Used	
8	Not Used	



Ensure that all power is switched off before installing or maintaining this product

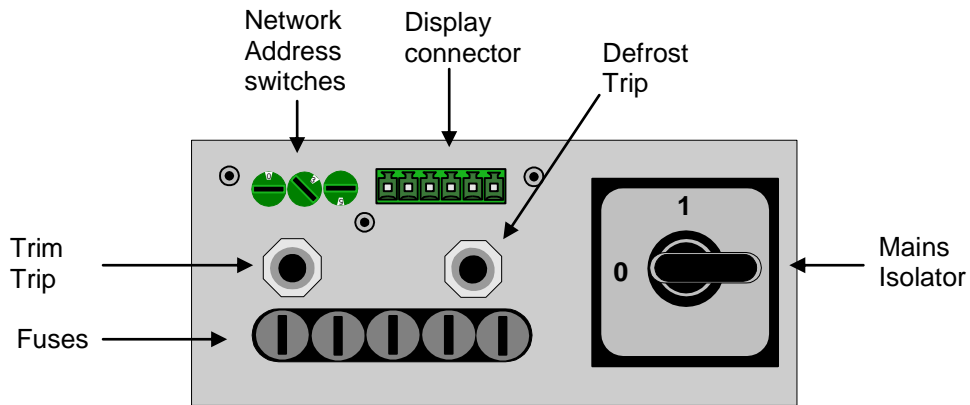
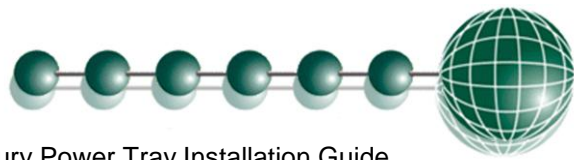

### Remote Display Connection

Connect a Mercury Remote Display (PR0325) or Remote Display with Key-switch (PR0326) in to the display connector. The Powertray is also compatible with the Mercury 2 Remote Display PR0725 providing the Powertray is operating software version V10.1 or above.

This will provide all the standard set-up functions.

### Network Address Switches

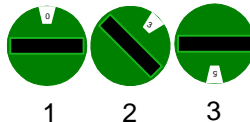

The 3 Network Address switches are used to select the desired network address.

We recommend that these switches are set to Bay Number (switches 1 & 2); Case number (switch 3), although any unique setting is valid.

The switches can be set to "000" for stand-alone (no network) operation.

Note: When using this product with a Mercury Hub communication device, the 3 network address settings will over-ride the hub settings.



Ensure that all power is switched off before installing or maintaining this product

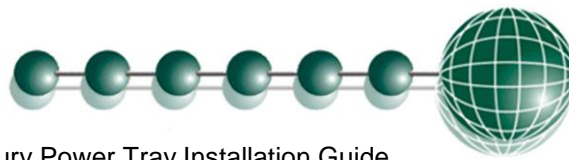

### Input/Output Allocation Tables

The following tables indicate; on a controller type basis, the functions of the inputs and outputs. Also the digital inputs which are derived by switching in a fixed value resistor across the input

#### Input / Output allocation tables for the 6-5M

Case Controller (Type 3 & 4)	Models: M & MT	Alarm Action	Plant input (switched resistors *)
Input 1	Air on Temperature	Yes	
Input 2	Air off Temperature	Yes	
Input 3	Evaporator Temperature	No	Plant fault 1
Input 4	Suction Line Temperature	No	Case Clean Switch
Input 5	Defrost Termination (if used)	No	
Input 6	Logging Probe (If fitted)	Conditional	
Relay 1	Liquid Line Valve (N/C)	N/A	
Relay 2	Fans (N/C)	N/A	
Relay 3	Lights (N/C)	N/A	
Relay 4	Suction Line Valve/Trim Heater (N/O)	N/A	
Relay 5	Defrost Heater (N/O)	N/A	

\* For PT1000 probes, use 820 Ohm switched resistors  
For NTC2K and NTC2K25 probes, use 590 Ohm switched resistors

#### Input / Output allocation tables for 6-5E

Case Controller (Type 3 & 4)	Models: E	Alarm Action	Plant input (switched resistors*)
Input 1	Air on Temperature	Yes	Plant Fault 1
Input 2	Air off Temperature	Yes	Case Clean
Input 3	Evaporator Temperature	Yes	
Input 4	Suction Line Temperature	Yes	
Input 5	Defrost Termination (if used)	No	
Input 6	Logging Probe (If Fitted)	Conditional	
Relay 1	Liquid Line Valve (N/C)	N/A	
Relay 2	Fans (N/C)	N/A	
Relay 3	Lights (N/C)	N/A	
Relay 4	Suction Line Valve/Trim Heater (N/O)	N/A	
Relay 5	Defrost Heater (N/O)	N/A	

\* For PT1000 probes, use 820 Ohm switched resistors  
For NTC2K and NTC2K25 probes, use 590 Ohm switched resistors



Ensure that all power is switched off before installing or maintaining this product

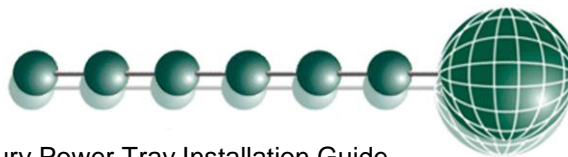

## Setting up the controller

Access to the controller can be achieved several ways

- Through the remote display buttons
- Direct access by PC or palm top into the RS232 comms port. This requires a software package available on the RDM website
- Through legacy front end panels on 485 networks
- Through the RDM Data Director.

### Setup Mode

#### Setup through front buttons



To enter setup mode, hold the Enter and Down buttons together for approximately 3 seconds until the message “Ent” appears on the display. Now press the Enter button again to enter the function menu. IO will be displayed. Scroll up or down to go through the list.

### Setup Function Menu

(Common to all types)

Display	Option	Explained in Paragraph
IO	View Inputs / Outputs and States	<a href="#">Input / output table</a>
PARA	Set/View Parameters	<a href="#">Set view parameters</a>
Unit	Probe type and Celsius/Fahrenheit option	<a href="#">Set View Unit</a>
tyPE	Set/View Controller Type	<a href="#">Set/view controller type</a>
rtc	Set/view Clock (rtc = Real Time Clock)	<a href="#">Real Time Clock</a>
nEt	Set/view network configuration	<a href="#">Network Configuration</a>
SoFt	View software version	
dEF	Start Defrost	<a href="#">Defrost</a>
FANS	Toggle Fans Only mode	<a href="#">Fans</a>
CASE	Toggle Case Off mode	<a href="#">Case Off</a>
Lits	Toggle Lights Only mode	<a href="#">Lights</a>
ESC	Exit Setup mode	



Ensure that all power is switched off before installing or maintaining this product

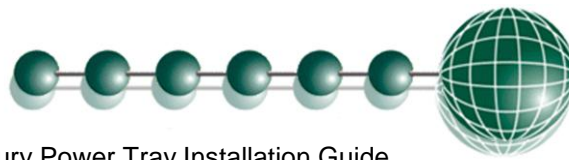

### Recommended set-up method

If you are not connecting to a network and want to set up the controller through the buttons we recommend you use the following order from the function menu.

#### rtc. Real time clock (This will automatically synchronise on network systems)

- a. Use the up or down buttons to scroll through the display until the display reads “rtc”
- b. Press enter. The display will show “t-1”. press enter again
- c. Scroll hours up or down (0 – 23) press enter
- d. Use up button to select “t-2”, press enter
- e. Scroll minutes up or down (0 – 59) press enter
- f. Repeat for t-3 (seconds 0 – 59)
- g. Repeat for t -4 (Days up to 31)
- h. Repeat for t -5 (months up to 12)
- i. Repeat for t -6 (Year up to 99)
- j. Use up button to display “ESC”, press enter to display “rtc”

Time clock is now set

#### type. Set/view controller type

- a. From the function menu scroll to select type, press enter
- b. Use the up/down buttons to scroll through case/coldroom configuration types. (see [configuration table on](#) page 4)
- c. Press enter.
- d. Scroll to select “ESC”
- e. Press enter

Controller type configuration is now set



Ensure that all power is switched off before installing or maintaining this product

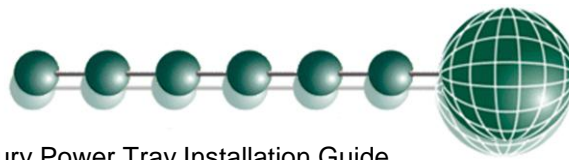

### PArA. Set/view parameters (This can be achieved at the network front end)

- a. From the function menu scroll to select PArA
- b. Pressing Enter while PArA is displayed will enter the parameter menu. The first parameter option will be displayed as P-01. Pressing the Up or Down button will present the other parameter options P-02, P-03 etc. See the parameter list below to find what parameter number corresponds to which actual parameter. Pressing the Enter button will show the current value of the selected parameter. Press Up or Down to modify the value and press Enter again to save the value. The parameter list number will be displayed again. Two other options are present in the parameter menu – dFLt and ESC. Selecting ESC will exit setup mode. Selecting dFLt will reset all parameters back to the default values for the current type of controller.

### Unit. Set/view temperature unit and Probe type

From the function menu scroll to select Unit

Press enter and the value will be displayed: -

#### Probe Types

- 0 for PT1000 Celsius
- 1 for PT1000 Fahrenheit
- 2 for NTC2K Celsius
- 3 for NTC2K Fahrenheit
- 4 for NTC2K25 Celsius
- 5 for NTC2K25 Fahrenheit

**Note:** Temperature range for NTC2K25 is restricted to -37 °C to +54 °C for probe inputs with a secondary function (switched resistors) and -37 °C to +60 °C for inputs that have no secondary function.

Use the up or down keys to select the units and press enter.

This function is now complete



Ensure that all power is switched off before installing or maintaining this product

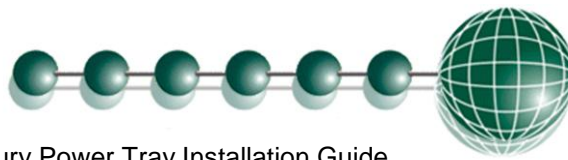

**Parameter Tables:**

**Parameter table for type M**

Number	Parameter	Range °C ( °F )	Step	Units	Def. LT °C (°F)	Def. HT °C (°F)
P-01	Cut-in Temp	-42 to 30 (-43.6 to 86)	0.1	Deg	-20 (-4)	0.0 (32)
P-02	Diff	0 to 10 (0 to 18)	0.1	Deg	2 (3.6)	1.5 (2.7)
P-03	Control Weight	0 to 100	1	%	50	50
P-04	Display Weight	0 to 100	1	%	50	50
P-12	Relay 4 Mode	0 = Suction Line 1 = Trim Heater			0	0
P-13	Trim in Defrost	0 (Off), 1(On)			0	0
P-14	Trim Level	0 to 100	1	%	100	100
P-85	Key-switch Mode	0 = Case Off 1 = Fans only 2 = toggle	1		0	0
P-87	Control Probe type	0 = Use Air on Probe 1 = Use Log Probe	1		0	0
P-90	Resistor Case Off	0 (Disabled), 1 (Enabled)			0	0
P-92	Fans Temp Mode	0 = Off 1 = Temperature 2 = Over-temperature 3 = Temp/OT			0	0
P-93	Fans Off Temp	-42 to 30 (-43.6 to 86)	0.1	Deg	-10 (14)	8 (46.4)
P-20	Alarm Delay	00:00 to 99:00	01:00	mm:ss	20:00	20:00
P-21	UT Alarm	-49 to 60 (-56.2 to 140)	0.1	Deg	-30 (-22)	-2 (28.4)
P-22	OT Alarm	-49 to 60 (-56.2 to 140)	0.1	Deg	-15 (5)	5 (41)
P-23	Log Probe Type	0 (Off), 1 (Logging), 2 (Logging/Alarm)			Off	Off
P-24	Slug Log Probe	0 (Off), 1 (On)			Off	Off
P-25	Log Alarm Delay	00:00 to 99:00	01:00	mm:ss	20:00	20:00
P-26	Log UT Alarm	-49 to 60 (-56.2 to 140)	0.1	Deg	-35 (-31)	-1 (30.2)
P-27	Log OT Alarm	-49 to 60 (-56.2 to 140)	0.1	Deg	-12 (10.4)	6 (42.8)
P-40	Defrost Mode	0 (Local), 1 (Remote)			Local	Local
P-41	Defrost Start	00:00 to 23:59	00:01	hh:mm	01:00	01:00
P-42	Defrosts per Day	0 to 8	1		6	6
P-43	No Defrost Time	0 to 25	1	hours	8	8
P-44	Def Terminate	-42 to 30 (-43.6 to 86)	0.1	Deg	14 (57.2)	10 (50)
P-45	Def Min Time	00:00 to 99:00	01:00	mm:ss	05:00	05:00
P-46	Def Max Time	00:00 to 99:00	01:00	mm:ss	24:00	24:00
P-47	Drain Down	00:00 to 24:00	00:15	mm:ss	01:30	01:30
P-48	Recovery Time	00:00 to 99:00	01:00	mm:ss	30:00	30:00
P-89	Pump Down Time	00:00 to 99:00	01:00	mm:ss	00:00	00:00
P-86	Fan Delay mode	0 = Time 1 = Temp	1		Time	Time
P-49	Fan Delay	00:00 to 99:00	01:00	mm:ss	00:00	00:00
P-88	Fan Delay Temp	-42 to 30 (-43.6 to 86)	0.1	Deg	-20 (-4)	0.0 (32)
P-50	Fans In Defrost	0 (Off), 1 (On)			On	On
P-94	Defrost Hold	0 (Off), 1 (On)			0	0
P-60	Lights Mode	0 (Local), 1 (Remote), 2 (Man Off), 3 (Man On)			Local	Local



Ensure that all power is switched off before installing or maintaining this product



## Mercury Power Tray Installation Guide

P-61	Sun Lights On	00:00 to 23:59	00:01	hh:mm	08:00	08:00
P-62	Sun Lights Off	00:00 to 23:59	00:01	hh:mm	20:00	20:00
P-63	Mon Lights On	00:00 to 23:59	00:01	hh:mm	08:00	08:00
P-64	Mon Lights Off	00:00 to 23:59	00:01	hh:mm	20:00	20:00
P-65	Tue Lights On	00:00 to 23:59	00:01	hh:mm	08:00	08:00
P-66	Tue Lights Off	00:00 to 23:59	00:01	hh:mm	20:00	20:00
P-67	Wed Lights On	00:00 to 23:59	00:01	hh:mm	08:00	08:00
P-68	Wed Lights Off	00:00 to 23:59	00:01	hh:mm	20:00	20:00
P-69	Thu Lights On	00:00 to 23:59	00:01	hh:mm	08:00	08:00
P-70	Thu Lights Off	00:00 to 23:59	00:01	hh:mm	20:00	20:00
P-71	Fri Lights On	00:00 to 23:59	00:01	hh:mm	08:00	08:00
P-72	Fri Lights Off	00:00 to 23:59	00:01	hh:mm	20:00	20:00
P-73	Sat Lights On	00:00 to 23:59	00:01	hh:mm	08:00	08:00
P-74	Sat Lights Off	00:00 to 23:59	00:01	hh:mm	20:00	20:00
dFLt	Restore default values					



Ensure that all power is switched off before installing or maintaining this product

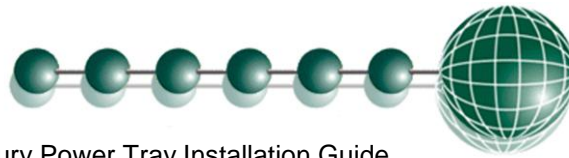

**Parameter table for type E**

Number	Parameter	Range °C ( °F )	Step	Units	Def. LT °C ( °F )	Def. HT °C ( °F )
P-01	Cut-in Temp	-42 to 30 (-43.6 to 86)	0.1	Deg	-20 (-4)	0.0 (32)
P-02	Diff	0 to 10 (0 to 18)	0.1	Deg	2 (3.6)	1.5 (2.7)
P-03	Control Weight	0 to 100	1	%	50	50
P-04	Display Weight	0 to 100	1	%	50	50
P-08	Superheat Ref	4 to 12 (7.2 to 21.6)	0.1	Deg	6 (10.8)	6 (10.8)
P-09	EEV Prop. Gain	0 to 10	0.1		2.2	2.2
P-10	EEV Integral Gain	0 to 10	0.1		1.8	1.8
P-11	EEV Integer Time	00:00 to 05:00	00:01	mm:ss	03:00	03:00
P-12	Relay 4 Mode	0 = Suction Line 1 = Trim Heater 2 = Hub Trim			0	0
P-13	Trim in Defrost	0 (Off), 1(On)			0	0
P-14	Trim Level	0 to 100	1	%	100	100
P-85	Key-switch Mode	0 = Case Off 1 = Fans only 2 = toggle	1		0	0
P-87	Control Probe type	0 = Use Air on Probe 1 = Use Log Probe	1		0	0
P-90	Resistor Case Off	0 (Disabled), 1 (Enabled)			0	0
P-92	Fans Temp Mode	0 = Off 1 = Temperature 2 = Over-temperature 3 = Temp/OT			0	0
P-93	Fans Off Temp	-42 to 30 (-43.6 to 86)	0.1	Deg	-10 (14)	8 (46.4)
P-95	Evap Select	0 (Local), 1 (Remote)	1			0
P-96	Div Value	0 to 100	1	%	100	100
P-20	Alarm Delay	00:00 to 99:00	01:00	mm:ss	20:00	20:00
P-21	UT Alarm	-49 to 60 (-56.2 to 140)	0.1	Deg	-30 (-22)	-2 (28.4)
P-22	OT Alarm	-49 to 60 (-56.2 to 140)	0.1	Deg	-15 (5)	5 (41)
P-23	Log Probe Type	0 (Off), 1 (Logging), 2(Logging/Alarm)			Off	Off
P-24	Slug log probe	0 (No), 1 (Yes)			No	No
P-25	Log Alarm Delay	00:00 to 99:00	01:00	mm:ss	20:00	20:00
P-26	Log UT Alarm	-49 to 60 (-56.2 to 140)	0.1	Deg	-35 (-31)	-1 (30.2)
P-27	Log OT Alarm	-49 to 60 (-56.2 to 140)	0.1	Deg	-12 (10.4)	6 (42.8)
P-40	Defrost Mode	0 (Local), 1 (Remote)			Local	Local
P-41	Defrost Start	00:00 to 23:59	00:01	hh:mm	01:00	01:00
P-42	Defrosts per Day	0 to 8	1		6	6
P-43	No Defrost Time	0 to 25	1	hours	12	12
P-44	Def Terminate	-42 to 30 (-43.6 to 86)	0.1	Deg	14 (57.2)	10 (50)
P-45	Def Min Time	00:00 to 99:00	01:00	mm:ss	05:00	05:00
P-46	Def Max Time	00:00 to 99:00	01:00	mm:ss	24:00	24:00
P-47	Drain Down	00:00 to 24:00	00:15	mm:ss	01:30	01:30
P-48	Recovery Time	00:00 to 99:00	01:00	mm:ss	30:00	30:00
P-89	Pump Down Time	00:00 to 99:00	01:00	mm:ss	00:00	00:00
P-86	Fan Delay mode	0 (Time), 1 (Temp)	1		0	0
P-49	Fan Delay	00:00 to 99:00	01:00	mm:ss	00:00	00:00



Ensure that all power is switched off before installing or maintaining this product

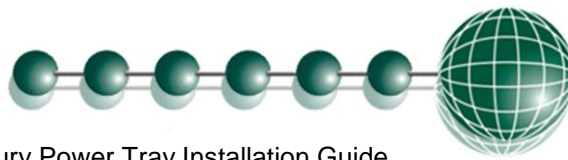

### Mercury Power Tray Installation Guide

P-88	Fan Delay Temp	-42 to 30 (-43.6 to 86)	0.1	Deg	-20 (-4)	0.0 (32)
P-50	Fans In Defrost	0 (Off), 1 (On)			On	On
P-94	Defrost Hold	0 (Off), 1 (On)			0	0
P-60	Lights Mode	0 (Local), 1 (Remote), 2 (Man Off), 3 (Man On)			Local	Local
P-61	Sun Lights On	00:00 to 23:59	00:01	hh:mm	08:00	08:00
P-62	Sun Lights Off	00:00 to 23:59	00:01	hh:mm	20:00	20:00
P-63	Mon Lights On	00:00 to 23:59	00:01	hh:mm	08:00	08:00
P-64	Mon Lights Off	00:00 to 23:59	00:01	hh:mm	20:00	20:00
P-65	Tue Lights On	00:00 to 23:59	00:01	hh:mm	08:00	08:00
P-66	Tue Lights Off	00:00 to 23:59	00:01	hh:mm	20:00	20:00
P-67	Wed Lights On	00:00 to 23:59	00:01	hh:mm	08:00	08:00
P-68	Wed Lights Off	00:00 to 23:59	00:01	hh:mm	20:00	20:00
P-69	Thu Lights On	00:00 to 23:59	00:01	hh:mm	08:00	08:00
P-70	Thu Lights Off	00:00 to 23:59	00:01	hh:mm	20:00	20:00
P-71	Fri Lights On	00:00 to 23:59	00:01	hh:mm	08:00	08:00
P-72	Fri Lights Off	00:00 to 23:59	00:01	hh:mm	20:00	20:00
P-73	Sat Lights On	00:00 to 23:59	00:01	hh:mm	08:00	08:00
P-74	Sat Lights Off	00:00 to 23:59	00:01	hh:mm	20:00	20:00
dFLt	Restore default settings					



Ensure that all power is switched off before installing or maintaining this product

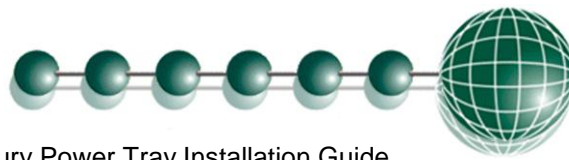

**Parameter Description :**

Number	Parameter	Description
P-01	Cut-in Temp	Temperature at which the LLV or EEV will switch on.
P-02	Diff	Differential temperature below the cut-in temperature. The LLV or EEV switches off when below this temperature
P-03	Control Weight	Percentage of the Air-On temperature that is used to calculate the control temp. The remaining percentage will be used on the Air-Off temperature Example : P-03 set to 30% Control temp = 30% Air-on + 70% Air-off
P-04	Display Weight	As above only applied to the display temperature
P-08	Superheat Ref	The controller will attempt to maintain this superheat value
P-09	EEV Prop. Gain	Affects the speed of response of the EEV (Best to leave at defaults)
P-10	EEV Integral Gain	Affects the speed of response of the EEV (Best to leave at defaults)
P-11	EEV Integer Time	Affects the speed of response of the EEV (Best to leave at defaults)
P-12	Relay 4 Mode	Relay 4 can be either a Suction, Trim Heater, or Trim Hub relay. <ul style="list-style-type: none"> <li>➤ Suction – Set for Suction Line Valve operation.</li> <li>➤ Trim Heater – Set as trim relay which pulses in accordance with P-14 or the Data Manager energy feature trim control.</li> <li>➤ Trim Hub – Relay is pulsed in accordance with the Trim Control feature present in the Mercury Switch (PR0018-PHI). Please see the Mercury switch (PR0018) user document for further details.</li> </ul>
P-13	Trim in Defrost	Allows the trims to be off or on during a defrost.
P-14	Trim Level	Sets a percentage level, of a 5-minute period, to pulse the trim heater relay off/on. Example: - P-14 set to 50% = 2.5 minutes on, 2.5 minutes off. If the controller is networked to a Data Manager operating the energy feature Trim Control then the Data Manager feature will override this parameter setting. Please refer to the Data Manager user document for further details. <b>Note</b> the trims are turned off when an over temperature alarm occurs.
P-85	Key-switch Mode	Allows the keys switch to be: - <ul style="list-style-type: none"> <li>➤ Single turn for case off (Case off mode)</li> <li>➤ Single turn for Fans only (Fans Mode)</li> <li>➤ Single turn for case off, double turn for fans only (Toggle mode)</li> </ul>
P-87	Control Probe type	Switches between using the air-on probe and the Logging probe. Note the control and display temperature will still be a derivative of the weighted Average of the control probe + Air-off probe
P-90	Resistor Case Off	Turns on/off the switched resistor case off function See : <a href="#">P-90 Note</a>
P-92	Fans Temp Mode	Allows the user to set the fans to turn off when: - <ul style="list-style-type: none"> <li>➤ A pre-determined temperature is reached (P93)</li> <li>➤ When an over-temperature alarm is present</li> <li>➤ When either P93 is reached or an OT alarm is present</li> </ul>
P-93	Fans Off Temp	Temperature for the above (P92) operation. <b>Note</b> the defrost termination probe is the source of the temperature reading used in this feature. If the defrost termination probe isn't fitted then a similar process to P-44 is used.
P-95	Evap Select	This allows the control algorithm to use a remote temperature input in place of the evaporator in value. In the event of no remote value being received, the control algorithm will revert to using the evaporator in probe value until the remote value is restored. Please see <a href="#">EEV Control Using Pressure</a> .



Ensure that all power is switched off before installing or maintaining this product

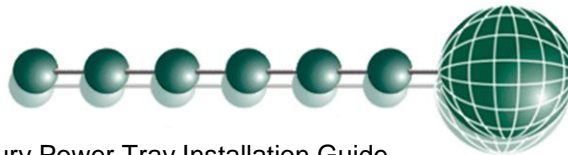

## Mercury Power Tray Installation Guide

P-96	Div Value	<p>This parameter only takes effect when the controller is used in conjunction with a Mercury Switch pressure application. When the Mercury Switch generates the MOP alarm the controller reduces the maximum valve opening to this percentage. For example if this parameter is set to 50% and the MOP alarm is generated then the maximum valve opening will be limited to 50%. Therefore as the controller pulses the valve the maximum the valve will open is 50%.</p> <p>Please see MOP : <a href="#">Maximum Operating Pressure</a> note.</p>
P-20	Alarm Delay	Delay for the over and under-temperature alarms
P-21	UT Alarm	Under temperature alarm set point. This alarm uses the control temperature.
P-22	OT Alarm	Over temperature alarm set point. This alarm uses the air-off temperature.
P-23	Log Probe Type	<p>Allows the user to set the logging probe mode: -</p> <ul style="list-style-type: none"> <li>➤ Off</li> <li>➤ Logging with no alarms</li> <li>➤ Logging with alarms</li> </ul>
P-24	Slug log probe	Applies a damping factor. This can be used to make a standard probe have the same temperature response as a logging probe.
P-25	Log Alarm Delay	Delay for the Logging probe over and under-temperature alarms
P-26	Log UT Alarm	Logging probe under temperature alarm set point
P-27	Log OT Alarm	Logging probe over temperature alarm set point
P-40	Defrost Mode	<p>Allows the user to set the defrost mode: -</p> <ul style="list-style-type: none"> <li>➤ Local (Uses the internal parameters P-41 and P-42)</li> <li>➤ Remote (Requires a defrost schedule in the front end)</li> </ul>
P-41	Defrost Start	When defrost mode is set to "Local", this is the start time for the 1 <sup>st</sup> defrost
P-42	Defrosts per Day	When defrost mode is set to "Local", this is the number of defrosts per day equally spaced from the start time.
P-43	No Defrost Time	If the controller misses a defrost command for any reason, a defrost will initiate after this time has elapsed from the last defrost. Normally set to 2 hours over the normal defrost period.
P-44	Def Terminate	<p>The defrost will terminate (defrost control relay off) when the temperature of the defrost termination probe reaches this value.</p> <p>If the "defrost termination" probe is not fitted, defrost termination will occur when: -</p> <p style="padding-left: 40px;">The "coil in" probe reaches the set point (If fans are selected as "off during defrost")</p> <p style="padding-left: 40px;">Or</p> <p style="padding-left: 40px;">The "air off" probe reaches the set point (If fans are selected as "on during defrost")</p> <p>If the "coil in" probe is not fitted, the "air off" probe will be used.</p>
P-45	Def Min Time	Minimum time that a defrost will use (Defrost can't terminate until this time has elapsed. If termination temperature is reached during this period, the defrost control relay is turned off, but the controller will not continue the defrost cycle until the end of the defrost min period)
P-46	Def Max Time	Time period after defrost minimum that defrosts are allowed to terminate
P-47	Drain Down	A period after defrost max to allow the draining of any surplus water
P-48	Recovery Time	The LLV is switched on at the start of this period to allow the temperature to recover to the normal operating point. This period also inhibits the OT alarm. Note that if the air-off temperature is still above the OT alarm set point when this period expires, an immediate OT alarm occurs; there is <b>not</b> a further alarm delay.
P-89	Pump Down Time	Time period before the defrost min period to allow for a pump down



Ensure that all power is switched off before installing or maintaining this product

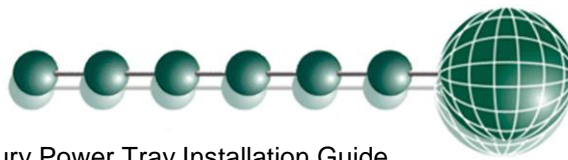

## Mercury Power Tray Installation Guide

P-86	Fan Delay mode	This parameter allows the fans start after a drain-down period to be delayed, either by time (P-49) or when the temperature point (P-88) is reached. This parameter uses the same probe strategy as the defrost terminate.
P-49	Fan Delay	Time after a drain-down period before the fans start if P-86 is set to time
P-88	Fan Delay Temp	Temperature at which the fans start after a drain-down period when P-86 is set to temperature.
P-50	Fans In Defrost	Allows the user to set the fans on or off in defrost. Note if the fans are set to on in defrost, they will go off for the drain-down period and then follow the P-86 rules.
P-94	Defrost Hold	Turns the defrost hold feature on and off. When switched on, the controller can be held in defrost until a remote command from the front end starts the recovery process.
P-60	Lights Mode	Allows the user to set the lights mode: - <ul style="list-style-type: none"> <li>➤ Always off</li> <li>➤ Always on</li> <li>➤ Use a local schedule P-61 to P-74)</li> <li>➤ Use a remote schedule (Set up in the system front end)</li> </ul>
P-61	Sun Lights On	When P-60 is set to Local, Sunday on time
P-62	Sun Lights Off	When P-60 is set to Local, Sunday off time
P-63	Mon Lights On	When P-60 is set to Local, Monday on time
P-64	Mon Lights Off	When P-60 is set to Local, Monday off time
P-65	Tue Lights On	When P-60 is set to Local, Tuesday on time
P-66	Tue Lights Off	When P-60 is set to Local, Tuesday off time
P-67	Wed Lights On	When P-60 is set to Local, Wednesday on time
P-68	Wed Lights Off	When P-60 is set to Local, Wednesday off time
P-69	Thu Lights On	When P-60 is set to Local, Thursday on time
P-70	Thu Lights Off	When P-60 is set to Local, Thursday off time
P-71	Fri Lights On	When P-60 is set to Local, Friday on time
P-72	Fri Lights Off	When P-60 is set to Local, Friday off time
P-73	Sat Lights On	When P-60 is set to Local, Saturday on time
P-74	Sat Lights Off	When P-60 is set to Local, Saturday off time
dFLt	Restore default settings	Restores all of the parameters to their default values

### P90 Note:

Parameter P90 default value is off, care must be taken when replacing an older controller with this version. If the Case Off function is required, this parameter must be changed to on.



Ensure that all power is switched off before installing or maintaining this product

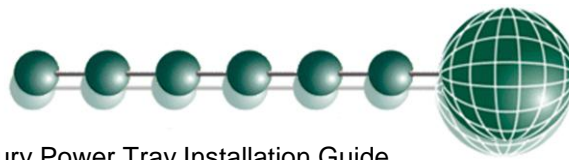

### EEV Control Using Pressure

The Mercury Switch (PR0018-PHI) can be used for EEV control on an Island by island basis. In an EEV application the evaporator in temperature probe reading for a case controller can be obtained from the Mercury switch on which the controller is connected. A suction pressure transducer is connected from the case Island to the 4-20mA input of the Mercury Switch and the pressure read from this transducer is converted to a temperature based on the gas type being used by the system. This temperature is transmitted to each controller connected to the switch and along with the suction temperature probe local to the controller the superheat is calculated. Please note that RDM recommended that the evaporator in temperature probe is fitted as the controller will use this to calculate the superheat in the event of a communication loss with the Mercury Switch. P-95 allows for the use of this remote temperature provided by the Mercury Switch. Please see the Mercury Switch user document (PR0018-PHI) for further details.

### Maximum Operating Pressure (MOP)

Maximum Operating Pressure (MOP) support added. MOP is a remote command sent from the Mercury switch (PR0018-PHI) to the controller to either close or reduce the EEV valve opening when a predetermined pressure is reached. This MOP value is configured in the Mercury switch setup. When the Mercury Switch generates the MOP alarm the controller reduces the maximum valve opening to this percentage. For example if the "Div Value" parameter is set to 50% and the MOP alarm is generated then the maximum valve opening will be limited to 50%. Therefore as the controller pulses the valve the maximum the valve will open to is 50%. For M controllers the LLV is closed for the MOP alarm duration.

### Relay and screen states during defrost

State:	Pump Down	Defrost Min	Defrost Max	Drain Down	Fan Delay	Recovery
Screen:	DEF	DEF	DEF	DEF	DEF	Pd
Def LED:	On	On	On	Off	Off	Off
RL1 1LLV	Closed	Closed	Closed	Closed	Open	Open
RL4 Suc	On	On	On	On	Off	Off
RL4 Trim on in defrost	On	On	On	On	On	On
RL4 Trim off in defrost	Off	Off	Off	Off	Off	On
RL5 Defrost Relay	Off	On	On	Off	Off	Off
RL3 Lights relay	On	On	On	On	On	On
RL2 Fan Relay (On in def)	On	On	On	On	Off	On
RL2 Fan Relay (Off in def)	Off	Off	Off	Off	Off	On

### Defrost Termination

Defrost termination will be when the temperature parameter "def terminate" has been reached on the "defrost termination" probe. If the "defrost termination" probe is not fitted, defrost termination will occur when: -

- Or The "coil in" probe reaches the set point (If fans are selected as "off during defrost")
- Or The "air off" probe reaches the set point (If fans are selected as "on during defrost")

If the "coil in" probe is not fitted, the "air off" probe will be used.



Ensure that all power is switched off before installing or maintaining this product

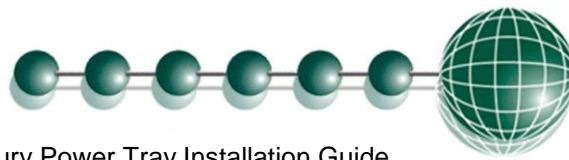

### Fan Delay after Defrost

The fans will come back on when: -

The fan delay time has elapsed if the "fan delay mode" is set to time

Or

If the fan delay mode is set to "temp", the fans will come on when the defrost termination probe reaches the fan delay set point, or on the time parameter, whichever occurs first.

If the "defrost termination" probe is not fitted, the fans will come on when: -

- Or      The "coil in" probe reaches the control set point (If fans are selected as "off during defrost")
- Or      The "air off" probe reaches the control set point (If fans are selected as "on during defrost")



Ensure that all power is switched off before installing or maintaining this product

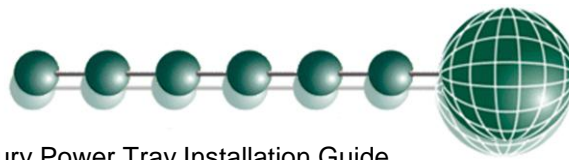

## Network Configuration

The final section to setup is the network address. In all instances, this must be done before the controller is plugged into the site network. The controllers have an auto-initialise function, which will automatically log the device onto the site network. If the wrong address has been entered onto the network, you will have to reset the controller address by setting the address to 00-0, and then re-enter the correct address. (You may have to deregister the wrong address from the home system as well).

To set the controller onto a network you must first connect the controller to a communications module if the model you are working on is a no communication variant. This is either a: -

- 485 Legacy, or (PR0026)
- IP Futura (PR0016)
- Mercury Hub / Switch (PR0018/018-PHI)

### 485 Legacy module

485 legacy support the following protocol: -

- Genus

Connecting a 485 legacy module to the controller will govern which set up screens are made available.

Display	Option
485t	485 Network Type
485A	485 Address/Name
gAdd *	Show underlying network address assigned to controller
rLog *	Re-log the controller back onto the network
CLrA *	Clear the address/name from the controller
ESC	Exit network menu. <b>N.B.</b> this option <b>must</b> be selected to save any changes made in this menu

\* These options are only available when the network type is set to Genus compatible.

The 485t option shows a value representing the network type. The possible values are:

Value	Network Type
1	Genus compatible (all versions)

The 485A option shows a value representing either the name of the controller in a Genus compatible network.

The value shown is of the form 05-6. This means the controller would try to log onto a Genus compatible network using the name 'RC05-6'.

The following options are also available when the network type is set to Genus compatible.

The gAdd option displays (in hexadecimal format) the underlying network address assigned to the controller when it was logged onto the network.

The rLog option allows the controller to be logged back onto the network with its current name. The 'rLog' message will flash for confirmation. Press the Enter button to execute the command, Up or Down buttons to cancel.



Ensure that all power is switched off before installing or maintaining this product

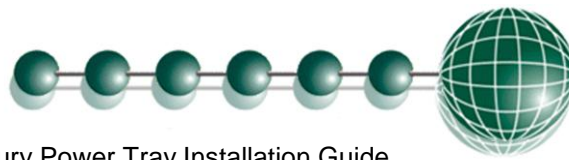

### Fast Network Address Reset

The **CLrA** option will clear out the network address and name in the controller. The 'ClrA' message will flash for confirmation. Press the Enter button to execute the command, Up or Down buttons to cancel.

To enter this mode, hold the Enter, Up and Down buttons together for approximately 3 seconds until the message **CLrA** appears on the display. **CLrA** is the first option in the menu consisting of the following options:

Display	Option
CLrA	Clear the address/name from the controller
ESC	Exit Setup mode

Pressing the Enter button to select the **CLrA** option will cause the 'CLrA' message to flash for confirmation, if the network type is set to Genus compatible. Press the Enter button to execute the command, Up or Down buttons to cancel. If the network type is not set to Genus compatible then the **CLrA** message will not flash and the ESC option can be used to exit the menu.

### IP Futura module

In an IP system there are two options

- IP-L
- IP-r

IP-L allows you to fix an IP address into the controller, which you would use when you are connecting the controllers onto a customer's local area network. This would allow the customer to view each controller using Internet Explorer

IP-r allows you to give each controller on the system a unique number. This number is then allocated a dynamic IP address by the system DHCP server (such as the RDM Data Director)

### IP-L

To configure the communication module for IP-L, set all three rotary switches to zero. The module should then be connected to the controller.

1. nEt. From the function menu you can now select nEt
  - Press enter and the display will show "IP-L", press enter
  - You can now set the address using the table below

Display	Option
IP-1	IP Address byte 1
IP-2	IP Address byte 2
IP-3	IP Address byte 3
IP-4	IP Address byte 4
nL	Network Mask Length
gt-1	Gateway Address byte 1
gt-2	Gateway Address byte 2
gt-3	Gateway Address byte 3
gt-4	Gateway Address byte 4
ESC	Exit network menu. <b>N.B.</b> this option <b>must</b> be selected to save any changes made in this menu



Ensure that all power is switched off before installing or maintaining this product

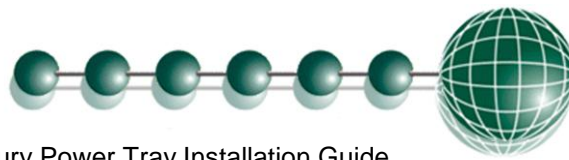

**IP-r**

To configure the communication module for IP-r, set the three rotary switches to give each controller a unique identifier. The module should then be connected to the controller and the network.

2. nEt. From the function menu you can now select nEt
  - Press enter and the display will show “IP-r”, press enter
  - You can now view only the address given by the DHCP server

To ease setup, a single network mask length value is used. If the address has been specified with a network mask value in dotted IP format e.g. 255.255.255.0 then the table below gives the conversion:

Mask	Length	Mask	Length	Mask	Length
		255.255.254.0	23	255.254.0.0	15
255.255.255.252	30	255.255.252.0	22	255.252.0.0	14
255.255.255.248	29	255.255.248.0	21	255.248.0.0	13
255.255.255.240	28	255.255.240.0	20	255.240.0.0	12
255.255.255.224	27	255.255.224.0	19	255.224.0.0	11
255.255.255.192	26	255.255.192.0	18	255.192.0.0	10
255.255.255.128	25	255.255.128.0	17	255.128.0.0	09
255.255.255.0	24	255.255.0.0	16	255.0.0.0	08



Ensure that all power is switched off before installing or maintaining this product

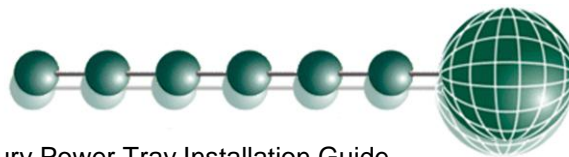

## Viewing

Apart from setting up the controller, you can also view the status of the inputs and outputs.

1. IO. View Inputs / Outputs and States
  - a. From the function menu, select "IO", press enter
  - b. You can now scroll through the IO tables as set out below. The tables you view will depend on the controller type configuration.

### Input/Output table for Case Controller M

Number	IO	Range (dependant on probe type) °C ( °F )	Step	Units
I-01	Control Temp.	-42 to 60 (-43.6 to 140)	0.1	Deg
I-02	Display temp	-42 to 60 (-43.6 to 140)	0.1	Deg
I-03	Air on Probe	-49 to 60 (-56.2 to 140)	0.1	Deg
I-04	Air off Probe	-49 to 60 (-56.2 to 140)	0.1	Deg
I-05	Evaporator Probe	-42 to 60 (-43.6 to 140)	0.1	Deg
I-06	Suction Line Probe	-42 to 60 (-43.6 to 140)	0.1	Deg
I-07	Superheat	-30 to 60 (-54 to 108)	0.1	Deg
I-08	Logging Probe	-49 to 60 (-56.2 to 140)	0.1	Deg
I-09	Defrost Probe	-49 to 60 (-56.2 to 140)	0.1	Deg
I-10	Plant Fault	0 (OK), 1 (Alarm)		
I-11	Case Clean	0 (Off), 1 (On)		
O-01	Liquid Line Valve	0 (Off), 1 (On)		
O-05	Defrost Control	0 (Off), 1 (On)		
O-06	Lights	0 (Off), 1 (On)		
O-07	Case Fans	0 (Off), 1 (On)		
O-10	Last Def. Time	00:00 to 23:59		hh:mm
O-11	Last Def. Length	00:00 to 03:00		hh:mm
O-12	Last Def. Ctrl Temp.	-42 to 60 (-43.6 to 140)	0.1	hh:mm
O-13	Last Def. Type	0 (None), 1 (Internal), 2 (External), 3 (Network), 4 (Display), 5 (Timed)		
O-14	Suction Line Valve/Trim Heaters	0 (Open/Off), 1 (Closed/On)		
O-30	Set Point Offset	-49 to 60 (-56.2 to 140)	0.1	Deg
O-31	Trim Off Period	00:00 to 05:00	00:01	mm:ss
S-01	Control State	0 (Stabilise), 1 (Normal), 2 (Defrost Min), 3 (Defrost Max), 4 (Drain Down), 5 Fan Delay 6 (Recovery), 7 (OT Alarm), 8 (UT Alarm), 9 (Fans Only), 10 (Lights Only), 11 (Case Off), 12 (Pump Down) 13 (Defrost Hold)		



Ensure that all power is switched off before installing or maintaining this product

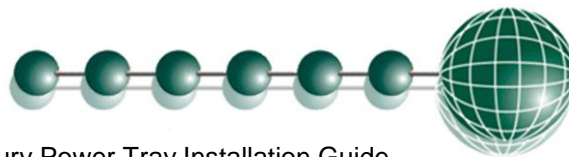

**Input/Output table for Case Controller E**

Number	IO	Range (dependant on probe type) °C ( °F )	Step	Units
I-01	Control Temp.	-42 to 60 (-43.6 to 140)	0.1	Deg
I-02	Display temp	-42 to 60 (-43.6 to 140)	0.1	Deg
I-03	Air on Probe	-42 to 60 (-43.6 to 140)	0.1	Deg
I-04	Air off Probe	-42 to 60 (-43.6 to 140)	0.1	Deg
I-05	Evaporator Probe	-49 to 60 (-56.2 to 140)	0.1	Deg
I-06	Suction Line Probe	-49 to 60 (-56.2 to 140)	0.1	Deg
I-07	Superheat	-30 to 60 (-54 to 108)	0.1	Deg
I-08	Logging Probe	-49 to 60 (-56.2 to 140)	0.1	Deg
I-09	Defrost Probe	-49 to 60 (-56.2 to 140)	0.1	Deg
I-10	Plant fault	0 (OK), 1 (Alarm)		
I-11	Case Clean Switch	0 (Off), 1 (On)		
I-14	Remote Evap Temp	-49 to 60 (-56.2 to 140)	0.1	Deg
I-15	MOP	0 (Off), 1 (On)		
I-16	Hub Trim Level	0 to 100	1	%
O-05	Defrost Control	0 (Off), 1 (On)		
O-06	Lights	0 (Off), 1 (On)		
O-07	Case Fans	0 (Off), 1 (On)		
O-09	EEV Opening	0 to 100	0.1	%
O-10	Last Def. Time	00:00 to 23:59		hh:mm
O-11	Last Def. Length	00:00 to 03:00		hh:mm
O-12	Last Def. Ctrl Temp.	-42 to 60 (-43.6 to 140)	0.1	hh:mm
O-13	Last Def. Type	0 (None), 1 (Internal), 2 (External), 3 (Network), 4 (Display), 5 (Timed)		
O-14	Suction Line Valve	0 (Open), 1 (Closed)		
O-30	Set Point Offset	-49 to 60 (-56.2 to 140)	0.1	Deg
O-31	Trim Off Period	00:00 to 05:00	00:01	mm:ss
S-01	Control State	0 (Stabilise), 1 (Normal), 2 (Defrost Min), 3 (Defrost Max), 4 (Drain Down), 5 Fan Delay 6 (Recovery), 7 (OT Alarm), 8 (UT Alarm), 9 (Fans Only), 10 (Lights Only), 11 (Case Off), 12 (Pump Down) 13 (Defrost Hold)		



Ensure that all power is switched off before installing or maintaining this product

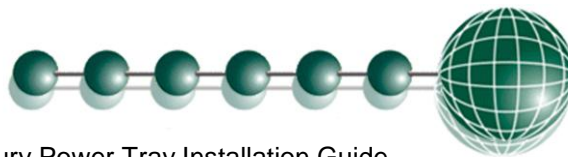

### Alarm Messages

The following alarms and messages can appear on the Mercury display.

Display Message	System status
Ft	Control Fault
Prb1	Probe 1 Fault
Prb2	Probe 2 Fault
Prb3	Probe 3 Fault
Prb4	Probe 4 Fault
Prb5	Probe 5 Fault
Prb6	Probe 6 Fault
Pd	Control State in Recovery
dEF	Control Sate in Defrost
AL	Control State in Alarm
FAnS ONLY	Controller in Fans Only
LitS ONLY	Controller in Lights Only
CASE OFF	Controller in Case Off
Ot	Over Temperature Alarm
Ut	Under Temperature Alarm
door	Door Open Alarm
TrAP	Person Trapped Alarm
PLnt	Plant Fault
LgOt	Log Probe Over Temperature
LgUt	Log Probe Under Temperature

### Network Alarms

The table below shows the text and associated type number that is sent to the system "front end". The type number is normally used to provide different alarm actions.

Alarm text	Type # (index)
Missed defrost	15
Plant Fault	3
Case over temperature	4
Case under temperature	5
Probe 1 Faulty	6
Probe 2 Faulty	6
Probe 3 Faulty	6
Probe 4 Faulty	6
Probe 5 Faulty	6
Probe 6 Faulty	6
Door Left Open	2
Product over temperature	8
Product under temperature	9
Person Trapped	1



Ensure that all power is switched off before installing or maintaining this product

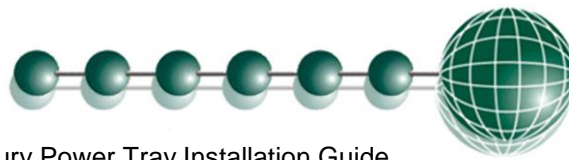

## Modifying controller states

During normal operation you can change the following states from the function menu

### Defrost “dEF”

Selecting the defrost option starts a defrost cycle. Selecting this option will exit the setup menu automatically. The display will show “dEF”

Defrosts can also be manually started by pressing and holding the display # button.

There is also a remote defrost command which starts a defrost cycle from the network front end or remote system.

### Fans Only “FAnS”

Selecting the Fans Only option will put the controller into the Fans Only state if the current state is not Fans Only. If the current state is Fans Only then the controller will change to the Normal state. Selecting this option will exit the setup menu automatically. The display will show “FAnS OnLy”

If a remote display with keyswitch is being used, this function can be invoked by turning the keyswitch to the fans only position (90 degrees clockwise) with parameter P85 set to "fans"

### Case Off “CASE”

Selecting the Case Off option will put the controller into the Case Off state if the current state is not Case Off. If the current state is Case Off then the controller will change to the Normal state. Selecting this option will exit the setup menu automatically. The display will show “CASE OFF”

If a remote display with keyswitch is being used, this function can be invoked by turning the keyswitch to the case-off position. (Clockwise 90 degrees) with parameter P85 set to "case"

### Lights Only “LitS”

Selecting the Lights Only option will put the controller into the Lights Only state if the current state is not Lights Only. If the current state is Lights Only then the controller will change to the Normal state. Selecting this option will exit the setup menu automatically. The display will show “LitS OnLy”



Ensure that all power is switched off before installing or maintaining this product

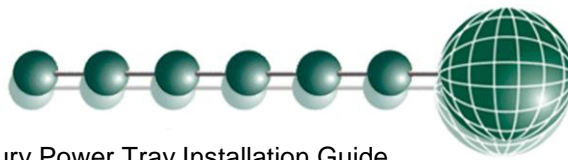

**Remote Commands:**

The following commands can be used by a Data Builder program: -

Command	Value to send	Description	Conditions;
Defrost Command	1	Initiates a defrost cycle	Defrost mode: remote
Defrost Command	3	Terminates the defrost	Defrost mode: remote Defrost hold: On Defrost min state complete
Trim Command	0 to 100%	Sets the trim level to this value (Trim period is 5 minutes)	Relay 4 mode: Trim Heater
Setpoint Command	$\pm 20^{\circ}\text{C}$ ( $\pm 34^{\circ}\text{F}$ )	Is added to or subtracted from the setpoint	
Case Off Command	5 0	Sets the controller to Case Off Restores the controller from Case Off to Normal	
EEV Command	2 1	Shuts the valve off Restores the valve to normal operation	

Use an “Analogue Out” block configured to the controller name and in the value field type in the command you require. Use a “Setting block” as the input to the “Analogue Out” block to send the Value.

See Example below, which sets the Trim Heater to BY10-1 at 40%

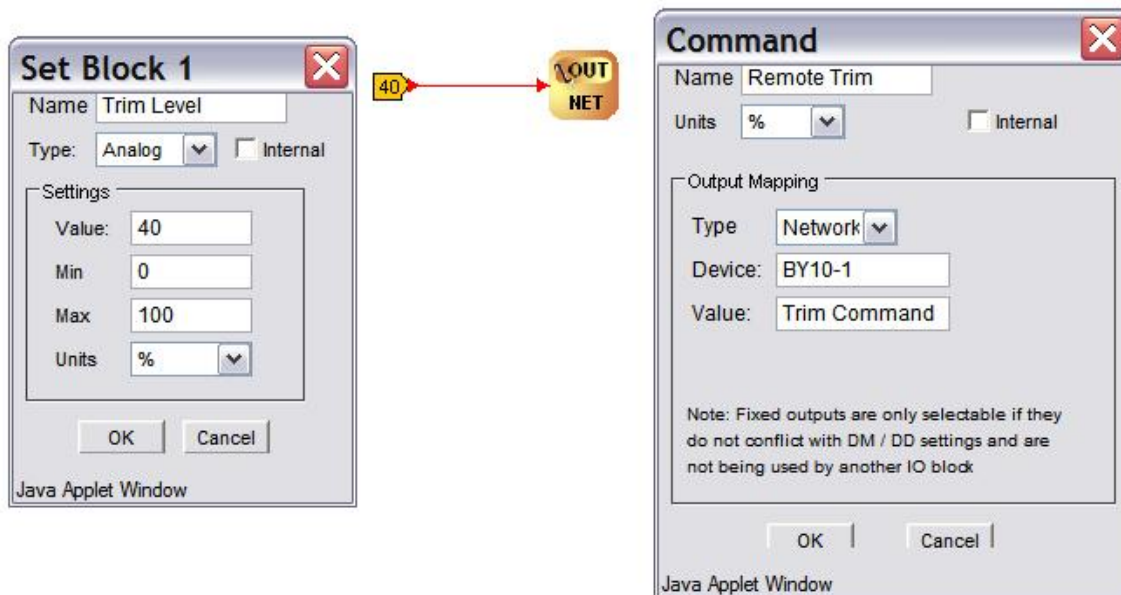

Ensure that all power is switched off before installing or maintaining this product

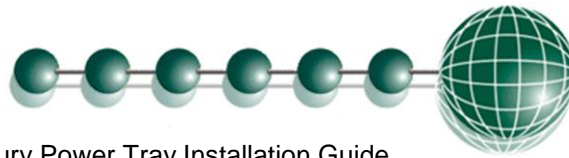

**Plant Input Resistors:**

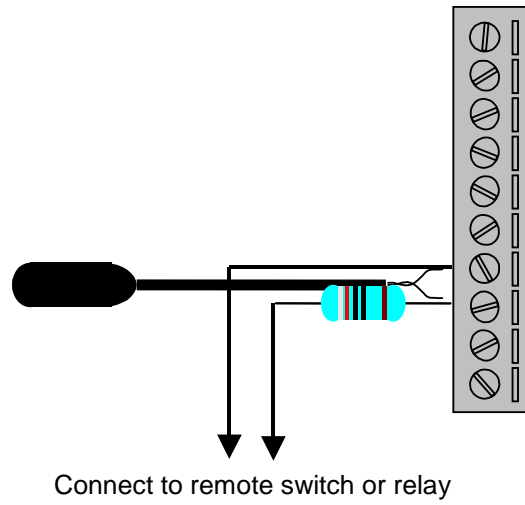

Example of resistor fitted on Air Off probe



Ensure that all power is switched off before installing or maintaining this product

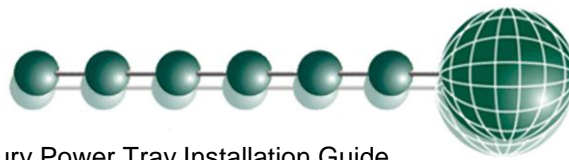

## Specification

### Power requirements:

Supply Voltage Range:	220 - 240 Vac $\pm$ 10%
Supply Frequency:	50 Hz
Maximum supply current:	32 Amps
Typical supply current:	Depends on loading
Operating temperature range:	+5 <sup>o</sup> C to +50 <sup>o</sup> C
Operating Humidity:	80% maximum
Storage temperature range:	-20 <sup>o</sup> C to +65 <sup>o</sup> C
Environmental:	Indoor use at altitudes up to 2000m, Pollution Degree 1, Installation Category II. Voltage fluctuations not to exceed $\pm$ 10% of nominal voltage
Size:	300mm (L) x 160mm (W) x 70mm (H)
Weight:	??? Grams
Safety:	EN61010
EMC:	EN61326; 1997 +Amdt. A1; 1998
Ventilation:	There is no requirement for forced cooling ventilation
Class 1 Insulation:	This unit <b><u>MUST</u></b> be earthed

### Inputs:

Input resistance:	3.01K Ohms (for PTC or NTC type probe)
Input type	PT1000 or NTC2K or NTC2K25 (selectable)
Comms:	RS232 with flow control (CPU board output) RS485 10baseT IP



Ensure that all power is switched off before installing or maintaining this product

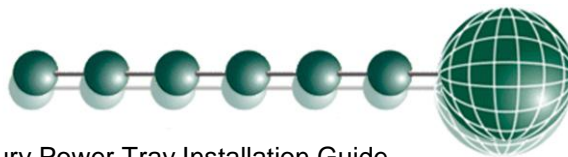

### Output ratings and fuses

The maximum current drawn collectively by all outputs, must not exceed 32A. Outputs are protected by either a fuse or a circuit breaker, see below.

Function	Circuit Rating Resistive	Circuit Rating Inductive	Fuse or Trip value
Defrost	18 Amps	5A at COSΦ=0.4	18 Amp Trip
LLV	7 Amp	3A at COSΦ=0.4	1 A @240 Vac 20mm antisurge (T) HRC fuse conforming to IEC60127
Fans	5.5 Amps	3A at COSΦ=0.4	2 A @240 Vac 20mm antisurge (T) HRC fuse conforming to IEC60127
Lights	5.5 Amps	3A at COSΦ=0.4	5 A @240 Vac 20mm antisurge (T) HRC fuse conforming to IEC60127
Suction Valve	2 Amps	2A at COSΦ=0.4	2 A @240 Vac 20mm antisurge (T) HRC fuse conforming to IEC60127
Gas Valve	1 Amp	1A at COSΦ=0.4	1 A @240 Vac 20mm antisurge (T) HRC fuse conforming to IEC60127
Trim Heater	7 Amps	3A at COSΦ=0.4	7 Amp Trip

Relay Life expectancy: 10 x 10<sup>6</sup> operations (no load condition)

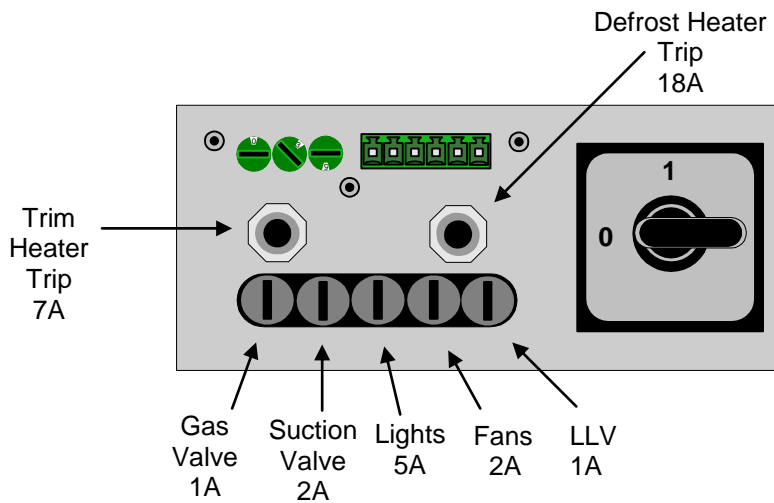

**Replace fuse with only those specified**

**Please Note.**

Warranty will be void if this equipment is used with any device that does not conform to this specification, particularly relay loads.



Ensure that all power is switched off before installing or maintaining this product

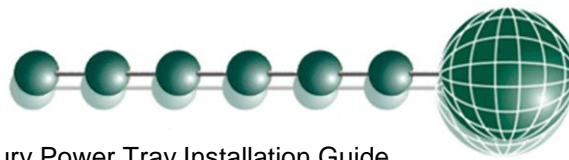

## Mating Connectors

Incoming mains connector mates with:	Weidmuller STVS 3 SB + STVS 3 ZE (Cable clamp)
Primary Function Connector mates with:	Weidmuller STVS 10 SS + STVS 10 ZE (Cable clamp)
Secondary Function Connector mates with:	Weidmuller STVS 10 SS + STVS 10 ZE (Cable clamp)

**Please note: The specifications of the product detailed on this set up guide may change without notice. RDM Ltd shall not be liable for errors or for incidental or consequential damages, directly or indirectly, in connection with the furnishing, performance or misuse of this product or document.**



Ensure that all power is switched off before installing or maintaining this product