

Mercury 6-5 Timer 5 Channel Timer Installation Guide



For Product: -

PR0315



Ensure that all power is switched off before installing or maintaining this product

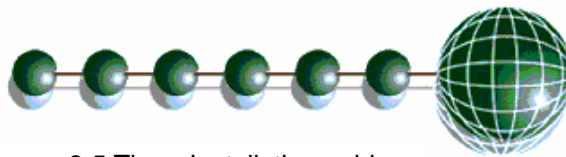

Table of Contents:

THE MERCURY RANGE 3

Description 3

Configuration 3

Networks..... 3

Connections 4

Input/Output Allocation Tables 4

Setting up the controller 5

 Set-up Mode..... 5

 Set-up through front buttons 5

 Set-up Function Menu..... 5

Recommended set-up method 5

 rtc. Real time clock (This will automatically synchronise on network systems)..... 5

 PArA. Set/view parameters (This can be achieved at the network front end) 6

Parameter Table:..... 7

 Parameter table for Timer 7

Network Configuration 9

 485 Legacy module..... 9

 Fast Network Address Reset 9

 IP Futura module..... 10

 IP-L 10

 IP-r..... 10

Normal Operation 11

Viewing 11

 Input/Output table for Timer 11

Display Messages..... 11

Network Alarms 11

Specification 12

 Power requirements:..... 12

 Relays 12

 Warning:..... 12

 Inputs: 13

Installation:..... 13

 Fixing:..... 13

 Clearances:..... 13

Wiring: 14

Cleaning: 14

Appendix 1 15

 GP Timer Configuration 15



Ensure that all power is switched off before installing or maintaining this product

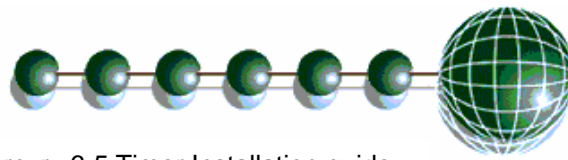

The Mercury Range

From Resource Data Management

This documentation refers to the 5 channel Timer

Description

The Mercury 6-5 Timer is a 5-channel timer module, each channel (relay output) has an independent time clock, which gives a single on/off per day. The remote option allows the unit to work from time channels running on a system front end such as the GP timer in the RDM Data Director. Each channel has a local over-ride switch (with alarm) that will turn the channel on and off when the timer clock is on the off period. (note: when the time clock is on the on period, the over-ride switch has no effect). If the timer is being used in remote mode, and drops offline, it will use its local settings.

Configuration

The controller is delivered pre-configured for 5 channels using the local (internal) timer

Networks

The controllers are capable of connecting to either a TCP/IP local area network or a RS485 network or controlling in standalone mode with no network output.

To connect to a network you must add the correct communications module.

- 485 Legacy module (Part No PR0026)
- IP Futura module (Part No PR0016)

Connecting to either of these communication modules will automatically be detected on power up and this will affect the set up screens made available to you.



Ensure that all power is switched off before installing or maintaining this product

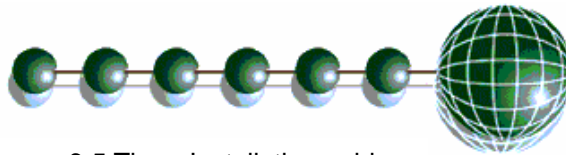

Connections

All connections are made to the back of the controller. The diagram below shows the connection detail. Inputs and outputs are assigned according to the chosen configuration. See [Specification](#) for further details on connections.

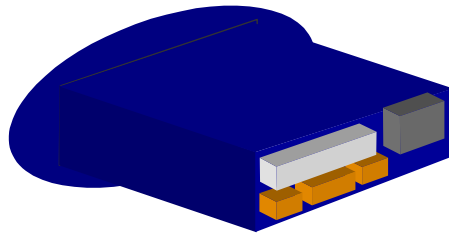

Communications

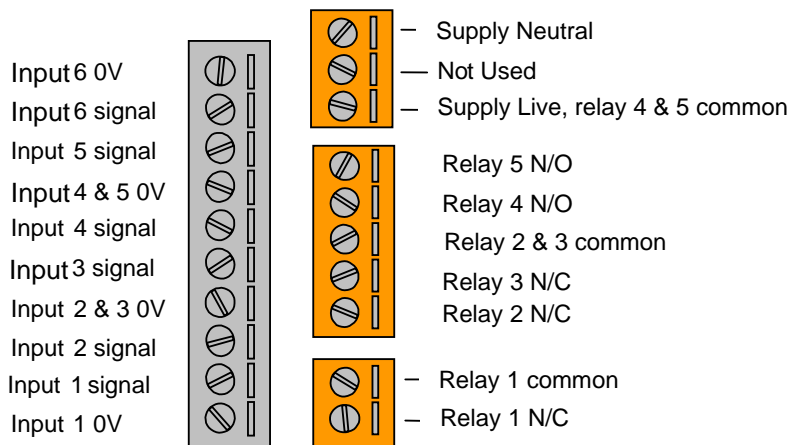

Do not connect an earth.



Input/Output Allocation Tables

Monitor	Description	Alarm Action	Comments
Input 1	Over-ride channel 1	Yes	0 volt return
Input 2	Over-ride channel 2	Yes	0 volt return
Input 3	Over-ride channel 3	Yes	0 volt return
Input 4	Over-ride channel 4	Yes	0 volt return
Input 5	Over-ride channel 5	Yes	0 volt return
Input 6	No Used	N/A	N/A
Relay 1	Time channel 1 output	N/A	Normally closed
Relay 2	Time channel 2 output	N/A	Normally closed
Relay 3	Time channel 3 output	N/A	Normally closed
Relay 4	Time channel 4 output	N/A	Normally open
Relay 5	Time channel 5 output	N/A	Normally open



Ensure that all power is switched off before installing or maintaining this product

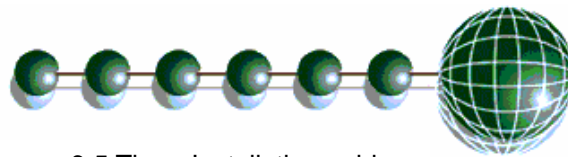

Setting up the controller

Access to the controller can be achieved several ways

- Through the front mounted buttons
- Direct access by PC or palm top into the rear comms port. This requires a software package available on the RDM website
- Through legacy front end panels on 485 networks
- Through the RDM Data Director.

Set-up Mode

Set-up through front buttons



To enter set-up mode, hold the Enter and Down buttons together for approximately 3 seconds until the message “Ent” appears on the display. Now press the Enter button again to enter the function menu. IO will be displayed. Scroll up or down to go through the list.

Set-up Function Menu

Display	Option	Explained in Paragraph
IO	View Input/Output States	View Input/Output States
PArA	Set/view Parameters	Set/view parameters
rtc	Set/view Clock (rtc = Real Time Clock)	Real Time Clock
nEt	Set/view network configuration	Network Configuration
SoFt	View software version	
ESC	Escape back to normal operation	

Recommended set-up method

If you are not connecting to a network and want to set up the controller through the buttons we recommend you use the following order from the function menu.

rtc. Real time clock (This will automatically synchronise on network systems)

- Use the up or down buttons to scroll through the display until the display reads “rtc”
- Press enter. The display will show “t-1”. press enter again
- Scroll hours up or down (0 – 23) press enter



Ensure that all power is switched off before installing or maintaining this product

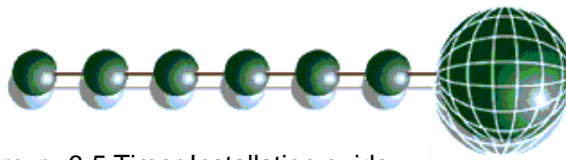

Mercury 6-5 Timer Installation guide

- d. Use up button to select "t-2", press enter
- e. Scroll minutes up or down (0 – 59) press enter
- f. Repeat for t-3 (seconds 0 – 59)
- g. Repeat for t -4 (Days up to 31)
- h. Repeat for t -5 (months up to 12)
- i. Repeat for t -6 (Year up to 99)
- j. Use up button to display "ESC", press enter to display "rtc"

Time clock is now set

PArA. Set/view parameters (This can be achieved at the network front end)

- a. From the function menu scroll to select PArA
- b. Pressing Enter while PArA is displayed will enter the parameter menu. The first parameter option will be displayed as P-01. Pressing the Up or Down button will present the other parameter options P-02, P-03 etc. See the parameter list below to find what parameter number corresponds to which actual parameter. Pressing the Enter button will show the current value of the selected parameter. Press Up or Down to modify the value and press Enter again to save the value. The parameter list number will be displayed again. Two other options are present in the parameter menu – dFLt and ESC. Selecting ESC will exit setup mode. Selecting dFLt will reset all parameters back to the default values for the current type of controller.



Ensure that all power is switched off before installing or maintaining this product

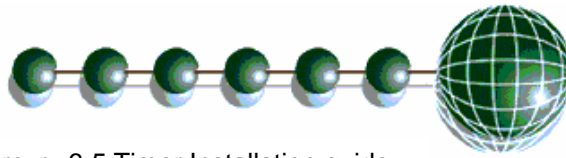

Parameter Table:
Parameter table for Timer

Number	Parameter	Range	Step	Units	Default	Comments
P-01	Relay operation	0 = local, 1 = remote	N/A	N/A	Local	See Note 1 below
P-02	Ch 1 Invert output	0 = normal 1 = invert			normal	
P-11	Channel 1 Sun On	00:00 to 23:59	00:01	hh:mm	08:00	
P-12	Channel 1 Sun Off	00:00 to 23:59	00:01	hh:mm	20:00	
P-13	Channel 1 Mon On	00:00 to 23:59	00:01	hh:mm	08:00	
P-14	Channel 1 Mon Off	00:00 to 23:59	00:01	hh:mm	20:00	
P-15	Channel 1 Tue On	00:00 to 23:59	00:01	hh:mm	08:00	
P-16	Channel 1 Tue Off	00:00 to 23:59	00:01	hh:mm	20:00	
P-17	Channel 1 Wed On	00:00 to 23:59	00:01	hh:mm	08:00	
P-18	Channel 1 Wed Off	00:00 to 23:59	00:01	hh:mm	20:00	
P-19	Channel 1 Thur On	00:00 to 23:59	00:01	hh:mm	08:00	
P-20	Channel 1 Thur Off	00:00 to 23:59	00:01	hh:mm	20:00	
P-21	Channel 1 Fri On	00:00 to 23:59	00:01	hh:mm	08:00	
P-22	Channel 1 Fri Off	00:00 to 23:59	00:01	hh:mm	20:00	
P-23	Channel 1 Sat On	00:00 to 23:59	00:01	hh:mm	08:00	
P-24	Channel 1 Sat Off	00:00 to 23:59	00:01	hh:mm	20:00	
P-03	Ch 2 Invert output	0 = normal 1 = invert			normal	
P-25	Channel 2 Sun On	00:00 to 23:59	00:01	hh:mm	08:00	
P-26	Channel 2 Sun Off	00:00 to 23:59	00:01	hh:mm	20:00	
P-27	Channel 2 Mon On	00:00 to 23:59	00:01	hh:mm	08:00	
P-28	Channel 2 Mon Off	00:00 to 23:59	00:01	hh:mm	20:00	
P-29	Channel 2 Tue On	00:00 to 23:59	00:01	hh:mm	08:00	
P-30	Channel 2 Tue Off	00:00 to 23:59	00:01	hh:mm	20:00	
P-31	Channel 2 Wed On	00:00 to 23:59	00:01	hh:mm	08:00	
P-32	Channel 2 Wed Off	00:00 to 23:59	00:01	hh:mm	20:00	
P-33	Channel 2 Thur On	00:00 to 23:59	00:01	hh:mm	08:00	
P-34	Channel 2 Thur Off	00:00 to 23:59	00:01	hh:mm	20:00	
P-35	Channel 2 Fri On	00:00 to 23:59	00:01	hh:mm	08:00	
P-36	Channel 2 Fri Off	00:00 to 23:59	00:01	hh:mm	20:00	
P-37	Channel 2 Sat On	00:00 to 23:59	00:01	hh:mm	08:00	
P-38	Channel 2 Sat Off	00:00 to 23:59	00:01	hh:mm	20:00	
P-04	Ch 3 Invert output	0 = normal 1 = invert			normal	
P-39	Channel 3 Sun On	00:00 to 23:59	00:01	hh:mm	08:00	
P-40	Channel 3 Sun Off	00:00 to 23:59	00:01	hh:mm	20:00	
P-41	Channel 3 Mon On	00:00 to 23:59	00:01	hh:mm	08:00	
P-42	Channel 3 Mon Off	00:00 to 23:59	00:01	hh:mm	20:00	
P-43	Channel 3 Tue On	00:00 to 23:59	00:01	hh:mm	08:00	
P-44	Channel 3 Tue Off	00:00 to 23:59	00:01	hh:mm	20:00	
P-45	Channel 3 Wed On	00:00 to 23:59	00:01	hh:mm	08:00	
P-46	Channel 3 Wed Off	00:00 to 23:59	00:01	hh:mm	20:00	
P-47	Channel 3 Thur On	00:00 to 23:59	00:01	hh:mm	08:00	
P-48	Channel 3 Thur Off	00:00 to 23:59	00:01	hh:mm	20:00	



Ensure that all power is switched off before installing or maintaining this product

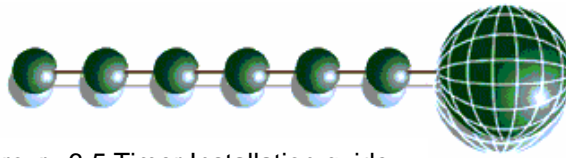

Mercury 6-5 Timer Installation guide

P-49	Channel 3 Fri On	00:00 to 23:59	00:01	hh:mm	08:00	
P-50	Channel 3 Fri Off	00:00 to 23:59	00:01	hh:mm	20:00	
P-51	Channel 3 Sat On	00:00 to 23:59	00:01	hh:mm	08:00	
P-52	Channel 3 Sat Off	00:00 to 23:59	00:01	hh:mm	20:00	
P-05	Ch 4 Invert output	0 = normal 1 = invert			normal	
P-53	Channel 4 Sun On	00:00 to 23:59	00:01	hh:mm	08:00	
P-54	Channel 4 Sun Off	00:00 to 23:59	00:01	hh:mm	20:00	
P-55	Channel 4 Mon On	00:00 to 23:59	00:01	hh:mm	08:00	
P-56	Channel 4 Mon Off	00:00 to 23:59	00:01	hh:mm	20:00	
P-57	Channel 4 Tue On	00:00 to 23:59	00:01	hh:mm	08:00	
P-58	Channel 4 Tue Off	00:00 to 23:59	00:01	hh:mm	20:00	
P-59	Channel 4 Wed On	00:00 to 23:59	00:01	hh:mm	08:00	
P-60	Channel 4 Wed Off	00:00 to 23:59	00:01	hh:mm	20:00	
P-61	Channel 4 Thur On	00:00 to 23:59	00:01	hh:mm	08:00	
P-62	Channel 4 Thur Off	00:00 to 23:59	00:01	hh:mm	20:00	
P-63	Channel 4 Fri On	00:00 to 23:59	00:01	hh:mm	08:00	
P-64	Channel 4 Fri Off	00:00 to 23:59	00:01	hh:mm	20:00	
P-65	Channel 4 Sat On	00:00 to 23:59	00:01	hh:mm	08:00	
P-66	Channel 4 Sat Off	00:00 to 23:59	00:01	hh:mm	20:00	
P-06	Ch 5 Invert output	0 = normal 1 = invert			normal	
P-67	Channel 5 Sun On	00:00 to 23:59	00:01	hh:mm	08:00	
P-68	Channel 5 Sun Off	00:00 to 23:59	00:01	hh:mm	20:00	
P-69	Channel 5 Mon On	00:00 to 23:59	00:01	hh:mm	08:00	
P-70	Channel 5 Mon Off	00:00 to 23:59	00:01	hh:mm	20:00	
P-71	Channel 5 Tue On	00:00 to 23:59	00:01	hh:mm	08:00	
P-72	Channel 5 Tue Off	00:00 to 23:59	00:01	hh:mm	20:00	
P-73	Channel 5 Wed On	00:00 to 23:59	00:01	hh:mm	08:00	
P-74	Channel 5 Wed Off	00:00 to 23:59	00:01	hh:mm	20:00	
P-75	Channel 5 Thur On	00:00 to 23:59	00:01	hh:mm	08:00	
P-76	Channel 5 Thur Off	00:00 to 23:59	00:01	hh:mm	20:00	
P-77	Channel 5 Fri On	00:00 to 23:59	00:01	hh:mm	08:00	
P-78	Channel 5 Fri Off	00:00 to 23:59	00:01	hh:mm	20:00	
P-79	Channel 5 Sat On	00:00 to 23:59	00:01	hh:mm	08:00	
P-80	Channel 5 Sat Off	00:00 to 23:59	00:01	hh:mm	20:00	

Note 1. When running in remote mode, if the controller goes off-line the controller will switch to local mode. It may be prudent to set up the parameters for this eventuality.



Ensure that all power is switched off before installing or maintaining this product

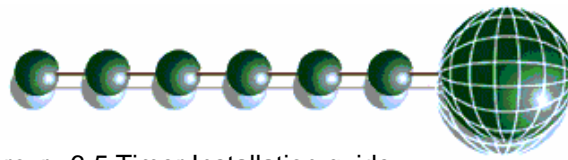

Network Configuration

The final section to set-up is the network address. In all instances, this must be done before the controller is plugged into the site network. The controllers have an auto-initialise function, which will automatically log the device onto the site network. If the wrong address has been entered onto the network, you will have to reset the controller address by setting the address to 00-0, and then re-enter the correct address. (You may have to deregister the wrong address from the home system as well).

To set the controller onto a network you must first connect the controller to a communications module. This is either a: -

- 485 Legacy, or
- IP Futura

485 Legacy module

- This product supports Genus compatible network protocol

Connecting a 485 legacy module to the controller will determine which set up screens are made available. Note: °F values are not supported on a RS485 network system.

Display	Option
485t	485 Network Type
485A	485 Address/Name
gAdd	Show underlying network address assigned to controller
rLog	Re-log the controller back onto the network
CLrA	Clear the address/name from the controller
ESC	Exit network menu. N.B. this option must be selected to save any changes made in this menu

The 485A option shows a value representing either the name of the controller in a Genus compatible network.

If the controller is set for Genus compatible then the value shown is of the form 05-6. This means the controller would try to log onto a Genus compatible network using the name 'RC05-6'.

The following options are only available when the network type is set to Genus compatible.

The gAdd option displays (in hexadecimal format) the underlying network address assigned to the controller when it was logged onto the network.

The rLog option allows the controller to be logged back onto the network with its current name. The 'rLog' message will flash for confirmation. Press the Enter button to execute the command, Up or Down buttons to cancel.

Fast Network Address Reset

Pressing the Enter button to select the CLrA option will cause the 'CLrA' message to flash for confirmation, if the network type is set to Genus compatible. Press the Enter button to execute the command, Up or Down buttons to cancel.



Ensure that all power is switched off before installing or maintaining this product

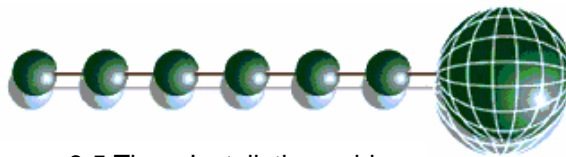

IP Futura module

In an IP system there are two options

- IP-L
- IP-r

IP-L allows you to fix an IP address into the controller, which you would use when you are connecting the controllers onto a customer's local area network. This would allow the customer to view each controller using Internet Explorer.

IP-r allows you to give each controller on the system a unique ID. This number is then allocated a dynamic IP address by the system DHCP server (such as the RDM Data Director)

IP-L

To configure the communication module for IP-L, set all three rotary switches on the communication module (PR0016) to zero. The module should then be connected to the controller.

1. nEt. From the function menu you can now select nEt
 - Press enter and the display will show "IP-L", press enter
 - You can now set the address using the table below

Display	Option
IP-1	IP Address byte 1
IP-2	IP Address byte 2
IP-3	IP Address byte 3
IP-4	IP Address byte 4
nL	Network Mask Length
gt-1	Gateway Address byte 1
gt-2	Gateway Address byte 2
gt-3	Gateway Address byte 3
gt-4	Gateway Address byte 4
ESC	Exit network menu. N.B. this option must be selected to save any changes made in this menu

IP-r

To configure the communication module for IP-r, set the three rotary switches to give each controller a unique identifier. The module should then be connected to the controller and the network.

The green network LED on the controller will flash until it has been logged on to the network. The Green network LED will remain permanently on while it is on-line.



Ensure that all power is switched off before installing or maintaining this product

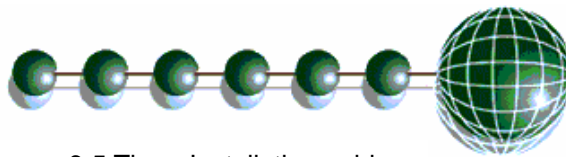

Normal Operation

During normal operation, the controller will display "on". If the Timer is on a network and on-line, the green network LED will be on.



The Network green LED flashes if the controller goes off-line or loses its given address.

Viewing

Apart from setting up the controller, you can also view the status of the inputs and outputs.

1. IO. View Inputs / Outputs and States
 - a. From the function menu, select "IO", press enter
 - b. You can now scroll through the IO tables as set out below. The tables you view will depend on the controller type configuration.

Input/Output table for Timer

Number	IO	Range	Step	Units
I-01	Input 1	0 = open, 1 = 0V	N/A	N/A
I-02	Input 2	0 = open, 1 = 0V	N/A	N/A
I-03	Input 3	0 = open, 1 = 0V	N/A	N/A
I-04	Input 4	0 = open, 1 = 0V	N/A	N/A
I-05	Input 5	0 = open, 1 = 0V	N/A	N/A
O-01	Relay 1	0 = off, 1 = on	N/A	N/A
O-02	Relay 2	0 = off, 1 = on	N/A	N/A
O-03	Relay 3	0 = off, 1 = on	N/A	N/A
O-04	Relay 4	0 = off, 1 = on	N/A	N/A
O-05	Relay 5	0 = off, 1 = on	N/A	N/A

Display Messages

The following messages can appear on the Mercury display.

Display	System status
on	Controller On

Network Alarms

Alarm	Type Number (Index)
Over-ride on	16 (All channels)



Ensure that all power is switched off before installing or maintaining this product

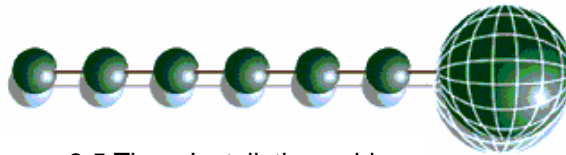

Specification

Power requirements:

Supply Voltage Range:	100 - 240 Vac \pm 10%
Supply Frequency:	50 - 60 Hz
Maximum supply current:	6.2 Amps (when relays 4 and 5 are fully loaded)
Typical supply current:	<1 Amp
Operating temperature range:	+5°C to +50°C
Operating Humidity:	80% maximum
Storage temperature range:	-20°C to +65°C
Environmental:	Indoor use at altitudes up to 2000m, Pollution Degree 1, Installation Category II. Voltage fluctuations not to exceed \pm 10% of nominal voltage
Size:	110mm (W) x 60mm (H) x 100mm (D)
Weight:	150 Grams
Safety:	EN61010
EMC:	EN61326; 1997 +Amdt. A1; 1998
Ventilation:	There is no requirement for forced cooling ventilation
Class 2 Insulation:	No protective Earth is required and none should be fitted.

The host equipment must provide a suitable external over-current protection device such as: -
 Fuse: 6.3A 240 Vac Antisurge (T) HRC conforming to IEC 60127
 Or MCB: 8A, 240 VAC Type C conforming to BS EN 60898

The host equipment must provide adequate protection against contact to hazardous live parts.

Relays

Max current relay 1:	6A (non inductive)	
Max Voltage relay 1:	260Vac (external supply)	
Exclusive common		
Max current relay 2:	4A (non inductive)	Relays 2 and 3 share a common supply line and the loads can have a combined total of 8A. Relay 2 or 3 can switch a maximum of 6A provided the other is at 2A or lower.
Max Voltage relay 2:	260Vac (external supply)	
Shared common with relay 3		
Max current relay 3:	4A (non inductive)	
Max Voltage relay 3:	260Vac (external supply)	
Shared common with relay 2		
Max current relay 4:	3A (non inductive)	
Max Voltage relay 4:	260Vac (Internal supply)	
Common connected to Input "live"		
Max current relay 5:	3A (non inductive)	
Max Voltage relay 5:	260Vac (Internal supply)	
Common connected to Input "live"		

For compliance with the LVD, relays 2 and 3 common must be at the same potential as the supply voltage.



Warning:

Relays 4 and 5 outputs have hazardous voltages (Supply input voltage potential).



Ensure that all power is switched off before installing or maintaining this product

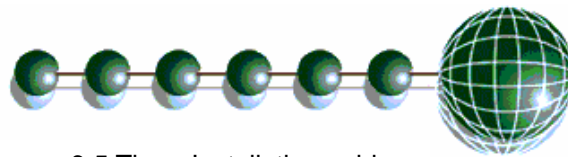

Inputs:

Input resistance: 3.01K Ohms (for PTC or NTC type probes)
Input type PT1000 for all versions

Comms: RS232 with flow control

Installation:

Panel Cut-out:

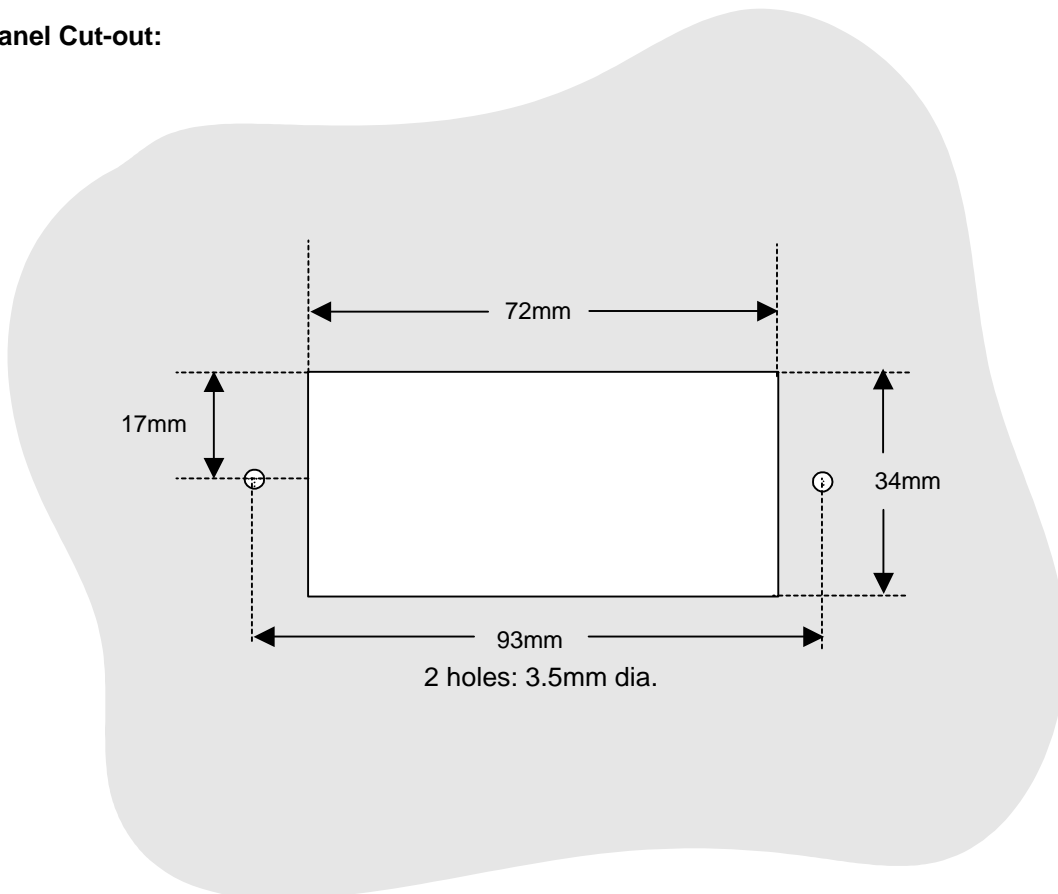

Fixing:

The controller can be fixed either by 2 X M3 screws from the rear or by the plastic retaining device (PR0329), obtainable from RDM.

Clearances:

The controller must have 5mm clearance above the top and below bottom, and 25mm clearance from the sides. Clearance at the rear is dependant on the wiring. There is no requirement for forced cooling ventilation



Ensure that all power is switched off before installing or maintaining this product

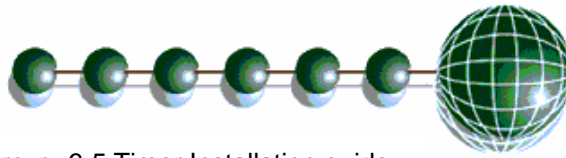

Wiring:

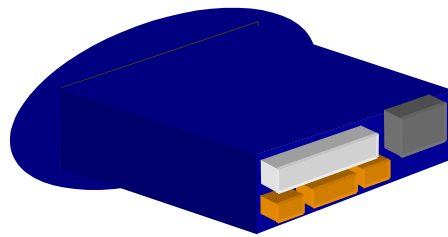

Communications socket

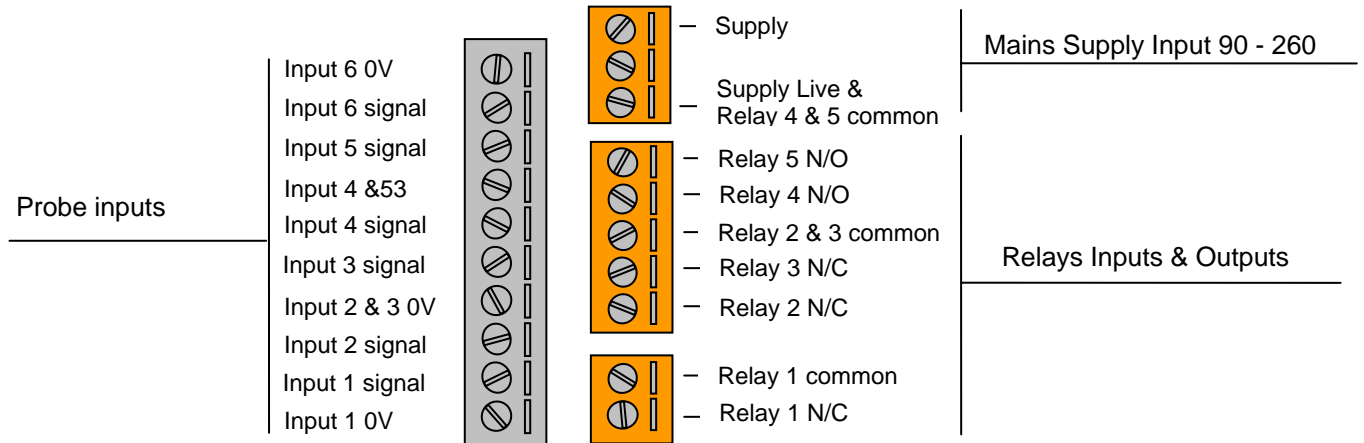

Relay 4 and 5 N/O are fed from the supply input

Note:

Suitable mechanical restraints on the wiring to the controller may be required; dependant on cable types, to prevent undue stress or distortion on the controller connectors.

Cleaning:

Do not wet the controller when cleaning. Clean the front by wiping with slightly dampened lint free cloth.



Ensure that all power is switched off before installing or maintaining this product

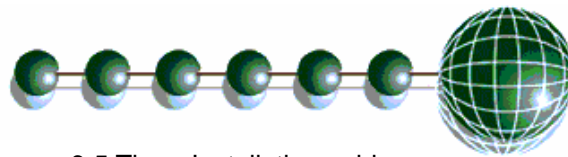

Appendix 1

GP Timer Configuration

If the Timer is used with an RDM Data Director or a Data Manager, the channels can be configured using the GP timer function. This allows for a much greater flexibility of on/off times, as well as master/slave operation.

From the "Home" screen, follow the links to the GP timer function:



Select a GP timing channel to configure by clicking the mouse on the channel required: -

RDM Hillington

Resource Data Management

Home

Back

Logout

Channel	Description	Status
1	Real test 1	On
2	Timer Channel for Relay 1	On
3	Jon Test Channel	Off
4	Jon office hours	On
5	MonCh5	On
6	GP Timer Channel 6	On
7	50 schedules	On
8	multiple times	Off
9	Slave for multiple times	Off
10	more multiple times	Off
11	slave 4 more mult times	Off
12	test rows	Off
13	test rows slave	Off
14	Timer for relay 2	On
15	Timer for relay 3	On
16	Timer for relay 4	On
17	Timer for relay 5 (slave to 2)	On
18	GP Timer Channel 18	Off

There are 100 GP timer channel to choose.

Once the channel has been selected, set the channel to master or slave and use the set-up wizard (by clicking on the "Add Schedule" button) to configure the required on/off times and days:



Ensure that all power is switched off before installing or maintaining this product

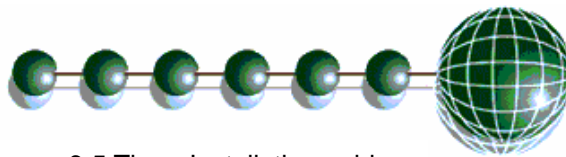

Mercury 6-5 Timer Installation guide

Once the wizard has been completed, add the relevant information in the other fields:

- Channel name (put in a meaningful name; eg. Timer channel for TC01-1 Relay 1)
- Output Type (set this field to general)
- Output mask (set this to the controller name you want the timer to act on; eg. TC01-1)
- Output Channel (set this to the output number of the controller you want the timer to act on. Note that this field starts at zero; so setting this field to 0 will act on Relay 1 etc)

GP Timer Channel Setup

Channel Type:

Channel Name:

Output Type: Output Mask: Output Channel:

Mon	Tues	Wed	Thurs	Fri	Sat	Sun
	1	2	3	4	5	6
7	8	9	10	11	12	13
14	15	16	17	18	19	20
21	22	23	24	25	26	27
28	29	30				

Key :
 Daily
 Weekly
 Yearly
 Once

Period 1
09:30 12:00

Period 2
15:00 16:00

Click the "Set Channel" once all the field values are correct.

Other GP channels can be used to configure the remaining relays.

Please note: The specifications of the product detailed on this set up guide may change without notice. RDM Ltd shall not be liable for errors or for incidental or consequential damages, directly or indirectly, in connection with the furnishing, performance or misuse of this product or document.



Ensure that all power is switched off before installing or maintaining this product