

Mercury 6-5 M Monitor Installation Guide



For Product: -

PR0314



Ensure that all power is switched off before installing or maintaining this product

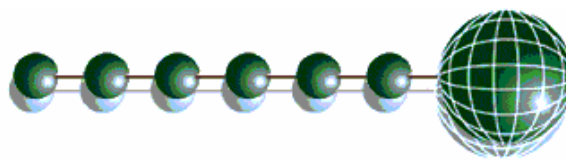
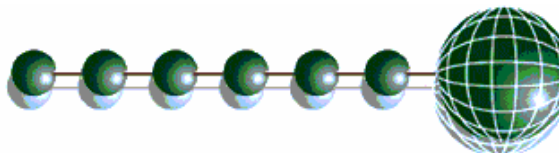

Table of Contents:

| | |
|--|-----------|
| THE MERCURY RANGE | 3 |
| Description | 3 |
| Configuration | 3 |
| Networks..... | 3 |
| Connections | 4 |
| Input/Output Allocation Tables | 4 |
| Setting up the controller | 5 |
| Set-up Mode..... | 5 |
| Set-up through front buttons | 5 |
| Set-up Function Menu..... | 5 |
| Recommended set-up method | 6 |
| rtc. Real time clock (This will automatically synchronise on network systems)..... | 6 |
| type. Set/view controller type | 6 |
| PArA. Set/view parameters (This can be achieved at the network front end) | 6 |
| Parameter Tables:..... | 7 |
| Parameter table for Monitor (Type 1)..... | 7 |
| Parameter table for Probe Tester (Type 2)..... | 8 |
| Units and Probe Type..... | 8 |
| Network Configuration | 9 |
| 485 Legacy module..... | 9 |
| Fast Network Address Reset | 9 |
| IP Futura module..... | 10 |
| IP-L | 10 |
| IP-r..... | 10 |
| Normal Operation | 11 |
| Defrost..... | 11 |
| Defrost Over-run | 11 |
| Faults | 11 |
| Network..... | 11 |
| Probe Offset | 11 |
| Inhibit Alarms | 11 |
| Alarm Relay Action: | 12 |
| Remote Relays | 12 |
| Viewing | 12 |
| Input/Output table for Monitor (Type 1)..... | 12 |
| Input/Output table for Probe Tester (Type 2)..... | 14 |
| Display Messages..... | 14 |
| Network Alarms | 16 |
| Specification | 17 |
| General | 17 |
| Power requirements:..... | 17 |
| Relays | 17 |
| Warning:..... | 17 |
| Inputs: | 17 |
| Installation:..... | 18 |
| Fixing:..... | 18 |
| Clearances:..... | 18 |
| Wiring: | 19 |
| Defrost Signal Resistors:..... | 19 |
| Fuse: | 20 |
| Cleaning: | 20 |



Ensure that all power is switched off before installing or maintaining this product



The Mercury Range

From Resource Data Management

This documentation refers to the 6 input monitor

Description

The Mercury 6 Monitor is a 6-channel temperature monitor with defrost inputs to inhibit alarms. Each input can be configured for temperature probe or plant fault (either N/C or N/O). Each channel can be independently configured for over and under temperature set points as well as alarm and recovery delays. The Monitor can operate stand-alone or be networked through either "legacy 485" or "IP" network modules. The Monitor can also be configured as a temperature probe tester, where the monitor simply records the values without generating alarms.

The monitor supports PT1000 or NTC2000 or NTC2k25 temperature probes (note all 6 inputs are either PT1000 or NTC2000 or NTC2k25)

Each input can be configured to have a temperature offset to compensate for long cable lengths.

Configuration

The controller is delivered pre-configured as a Temperature Monitor (Type 1)

The controller gives two configuration options: - (see [set-up](#) for changing the type)

| Display value | Type M |
|---------------|--|
| 1 | 6 channel temperature or fault monitor |
| 2 | 6 channel probe tester |

Networks

The controllers are capable of connecting to either a TCP/IP local area network or a RS485 network or controlling in standalone mode with no network output.

To connect to a network you must add the correct communications module.

- 485 Legacy module (Part No PR0026)
- IP Futura module (Part No PR0016)

Connecting to either of these communication modules will automatically be detected on power up and this will affect the set up screens made available to you.



Ensure that all power is switched off before installing or maintaining this product

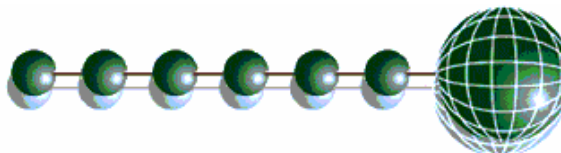

Connections

All connections are made to the back of the controller. The diagram below shows the connection detail. Inputs and outputs are assigned according to the chosen configuration. See [Specification](#) for further details on connections.

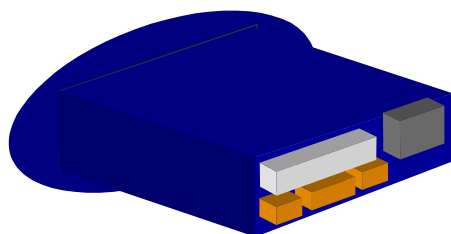

Communications socket

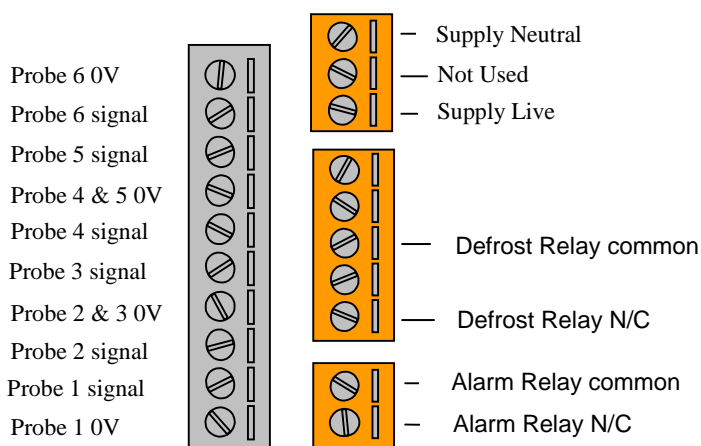

Do not connect an earth.



Input/Output Allocation Tables

Defrost states can be achieved by switching in a fixed value resistor in parallel with the probe inputs as shown in the table below.

| Monitor | Description | Alarm Action | (Switched Resistor)* |
|---------|--------------------------|--------------|----------------------|
| Input 1 | Probe 1 or Plant Fault 1 | Yes | Defrost signal 1 |
| Input 2 | Probe 2 or Plant Fault 2 | Yes | Defrost signal 2 |
| Input 3 | Probe 3 or Plant Fault 3 | Yes | Defrost signal 3 |
| Input 4 | Probe 4 or Plant Fault 4 | Yes | Defrost signal 4 |
| Input 5 | Probe 5 or Plant Fault 5 | Yes | Defrost signal 5 |
| Input 6 | Probe 6 or Plant Fault 6 | Yes | Defrost signal 6 |
| Relay 1 | Alarm (N/C) | N/A | |
| Relay 2 | Defrost | N/A | |
| Relay 3 | Not Used | N/A | |
| Relay 4 | Not Used | N/A | |
| Relay 5 | Not Used | N/A | |

* For PT1000 probes use 820 Ohm (see [Defrost Signal Resistors](#) section)
For NTC2000 and NTC2k25 probes use 590 Ohm



Ensure that all power is switched off before installing or maintaining this product

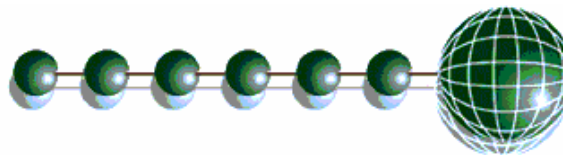

Setting up the controller

Access to the controller can be achieved several ways

- Through the front mounted buttons
- Direct access by PC or palm top into the rear comms port. This requires a software package available on the RDM website
- Through legacy front end panels on 485 networks
- Through the RDM Data Director or Data Manager.

Set-up Mode

Set-up through front bl



To enter set-up mode, hold the Enter and Down buttons together for approximately 3 seconds until the message “Ent” appears on the display. Now press the Enter button again to enter the function menu. IO will be displayed. Scroll up or down to go through the list.

Set-up Function Menu

| Display | Option | Explained in Paragraph |
|---------|--|--|
| IO | View Input/Output States | View Input/Output States |
| PARA | Set/view Parameters | Set/view parameters |
| Unit | Set Probe type and units (°C or °F) | Set/view units |
| TYPE | Set/View Controller Type | Set/view product type |
| rtc | Set/view Clock (rtc = Real Time Clock) | Real Time Clock |
| nEt | Set/view network configuration | Network Configuration |
| SoFt | View software version | |
| OFSt | Probe offset | Probe Offset |
| inh1 | Inhibit Channel 1 | Inhibit channel |
| inh2 | Inhibit Channel 2 | Inhibit channel |
| inh3 | Inhibit Channel 3 | Inhibit channel |
| inh4 | Inhibit Channel 4 | Inhibit channel |
| inh5 | Inhibit Channel 5 | Inhibit channel |
| Inh6 | Inhibit Channel 6 | Inhibit channel |
| ESC | Escape back to normal operation | |



Ensure that all power is switched off before installing or maintaining this product

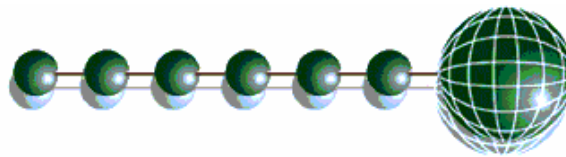

Recommended set-up method

If you are not connecting to a network and want to set up the controller through the buttons we recommend you use the following order from the function menu.

rtc. Real time clock (This will automatically synchronise on network systems)

- a. Use the up or down buttons to scroll through the display until the display reads "rtc"
- b. Press enter. The display will show "t-1". press enter again
- c. Scroll hours up or down (0 – 23) press enter
- d. Use up button to select "t-2", press enter
- e. Scroll minutes up or down (0 – 59) press enter
- f. Repeat for t-3 (seconds 0 – 59)
- g. Repeat for t-4 (Days up to 31)
- h. Repeat for t-5 (months up to 12)
- i. Repeat for t-6 (Year up to 99)
- j. Use up button to display "ESC", press enter to display "rtc"

Time clock is now set

type. Set/view controller type

- a. From the function menu scroll to select type, press enter
- b. Use the up/down buttons to scroll through monitor/tester configuration types. (see configuration table on page 4)
- c. Press enter.
- d. Scroll to select "ESC"
- e. Press enter

Controller type configuration is now set

PARA. Set/view parameters (This can be achieved at the network front end)

- a. From the function menu scroll to select PARa
- b. Pressing Enter while PARa is displayed will enter the parameter menu. The first parameter option will be displayed as P-01. Pressing the Up or Down button will present the other parameter options P-02, P-03 etc. See the parameter list below to find what parameter number corresponds to which actual parameter. Pressing the Enter button will show the current value of the selected parameter. Press Up or Down to modify the value and press Enter again to save the value. The parameter list number will be displayed again. Two other options are present in the parameter menu – dFLt and ESC. Selecting ESC will exit setup mode. Selecting dFLt will reset all parameters back to the default values for the current type of controller.



Ensure that all power is switched off before installing or maintaining this product

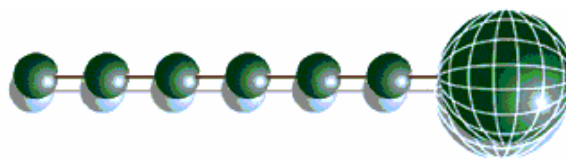

Parameter Tables:
Parameter table for Monitor (Type 1)

| Number | Parameter | Range | Step | Units | Default | Comments |
|--------|------------------|---|-------|-------|---------|--|
| P-01 | Channel 1 Select | 0 (Off), 1 (Probe), 2 (Plant N/C), 3 (Plant N/O) | | | 1 | Channel not used Temperature probe No 0 volt return = alarm 0 volt return = alarm |
| P-02 | C1 Slug Probe | 0 (No), 1 (Yes) | | | 0 | Electronic slugging |
| P-03 | Channel 1 UT | -42 - 128°C | 0.1 | Deg | -2.0 | Under temperature alarm |
| P-04 | Channel 1 OT | -42 - 128°C | 0.1 | Deg | 5.0 | Over temperature alarm |
| P-05 | C1 Alarm Delay | 00:00 to 99:00 | 01:00 | mm:ss | 20:00 | Alarm delay period |
| P-06 | C1 Recovery | 00:00 to 99:00 | 01:00 | mm:ss | 20:00 | Defrost recovery period |
| P-07 | C1 Inhibit | 00:00 to 99:00 | 01:00 | mm:ss | 30:00 | Inhibit alarms |
| P-08 | Defrost Over-run | 00:00 to 99:00 | 01:00 | mm:ss | 60:00 | Defrost Over-run |
| P-11 | Channel 2 Select | 0 (Off), 1 (Probe), 2 (Plant N/C), 3 (Plant N/O) | | | 1 | Channel not used Temperature probe No 0 volt return = alarm 0 volt return = alarm |
| P-12 | C2 Slug Probe | 0 (No), 1 (Yes) | | | 0 | Electronic slugging |
| P-13 | Channel 2 UT | -42 - 128°C | 0.1 | Deg | -2.0 | Under temperature alarm |
| P-14 | Channel 2 OT | -42 - 128°C | 0.1 | Deg | 5.0 | Over temperature alarm |
| P-15 | C2 Alarm Delay | 00:00 to 99:00 | 01:00 | mm:ss | 20:00 | Alarm delay period |
| P-16 | C2 Recovery | 00:00 to 99:00 | 01:00 | mm:ss | 20:00 | Defrost recovery period |
| P-17 | C2 Inhibit | 00:00 to 99:00 | 01:00 | mm:ss | 30:00 | Inhibit alarms |
| P-18 | Defrost Over-run | 00:00 to 99:00 | 01:00 | mm:ss | 60:00 | Defrost Over-run |
| P-21 | Channel 3 Select | 0 (Off), 1 (Probe), 2 (Plant N/C), 3 (Plant N/O) | | | 1 | Channel not used Temperature probe No 0 volt return = alarm 0 volt return = alarm |
| P-22 | C3 Slug Probe | 0 (No), 1 (Yes) | | | 0 | Electronic slugging |
| P-23 | Channel 3 UT | -42 - 128°C | 0.1 | Deg | -2.0 | Under temperature alarm |
| P-24 | Channel 3 OT | -42 - 128°C | 0.1 | Deg | 5.0 | Over temperature alarm |
| P-25 | C3 Alarm Delay | 00:00 to 99:00 | 01:00 | mm:ss | 20:00 | Alarm delay period |
| P-26 | C3 Recovery | 00:00 to 99:00 | 01:00 | mm:ss | 20:00 | Defrost recovery period |
| P-27 | C3 Inhibit | 00:00 to 99:00 | 01:00 | mm:ss | 30:00 | Inhibit alarms |
| P-28 | Defrost Over-run | 00:00 to 99:00 | 01:00 | mm:ss | 60:00 | Defrost Over-run |
| P-31 | Channel 4 Select | 0 (Off), 1 (Probe), 2 (Plant N/C), 3 (Plant N/O) | | | 1 | Channel not used Temperature probe No 0 volt return = alarm 0 volt return = alarm |
| P-32 | C4 Slug Probe | 0 (No), 1 (Yes) | | | 0 | Electronic slugging |
| P-33 | Channel 4 UT | -42 - 128°C | 0.1 | Deg | -2.0 | Under temperature alarm |
| P-34 | Channel 4 OT | -42 - 128°C | 0.1 | Deg | 5.0 | Over temperature alarm |
| P-35 | C4 Alarm Delay | 00:00 to 99:00 | 01:00 | mm:ss | 20:00 | Alarm delay period |
| P-36 | C4 Recovery | 00:00 to 99:00 | 01:00 | mm:ss | 20:00 | Defrost recovery period |

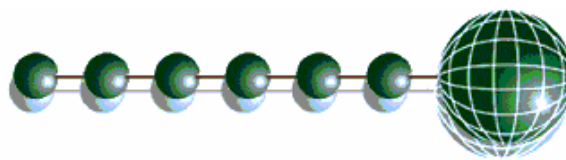

Ensure that all power is switched off before installing or maintaining this product

**Parameter table for Monitor (Type 1) Continued.....**

| Number | Parameter | Range | Step | Units | Default | Comments |
|--------|------------------|---|-------|-------|---------|--|
| P-37 | C4 Inhibit | 00:00 to 99:00 | 01:00 | mm:ss | 30:00 | Inhibit alarms |
| P-38 | Defrost Over-run | 00:00 to 99:00 | 01:00 | mm:ss | 60:00 | Defrost Over-run |
| P-41 | Channel 5 Select | 0 (Off), 1 (Probe), 2 (Plant N/C), 3 (Plant N/O) | | | 1 | Channel not used Temperature probe No 0 volt return = alarm 0 volt return = alarm |
| P-42 | C5 Slug Probe | 0 (No), 1 (Yes) | | | 0 | Electronic slugging |
| P-43 | Channel 5 UT | -42 - 128°C | 0.1 | Deg | -2.0 | Under temperature alarm |
| P-44 | Channel 5 OT | -42 - 128°C | 0.1 | Deg | 5.0 | Over temperature alarm |
| P-45 | C5 Alarm Delay | 00:00 to 99:00 | 01:00 | mm:ss | 20:00 | Alarm delay period |
| P-46 | C5 Recovery | 00:00 to 99:00 | 01:00 | mm:ss | 20:00 | Defrost recovery period |
| P-47 | C5 Inhibit | 00:00 to 99:00 | 01:00 | mm:ss | 30:00 | Inhibit alarms |
| P-48 | Defrost Over-run | 00:00 to 99:00 | 01:00 | mm:ss | 60:00 | Defrost Over-run |
| P-51 | Channel 6 Select | 0 (Off), 1 (Probe), 2 (Plant N/C), 3 (Plant N/O) | | | 1 | Channel not used Temperature probe No 0 volt return = alarm 0 volt return = alarm |
| P-52 | C6 Slug Probe | 0 (No), 1 (Yes) | | | 0 | Electronic slugging |
| P-53 | Channel 6 UT | -42 - 128°C | 0.1 | Deg | -2.0 | Under temperature alarm |
| P-54 | Channel 6 OT | -42 - 128°C | 0.1 | Deg | 5.0 | Over temperature alarm |
| P-55 | C6 Alarm Delay | 00:00 to 99:00 | 01:00 | mm:ss | 20:00 | Alarm delay period |
| P-56 | C6 Recovery | 00:00 to 99:00 | 01:00 | mm:ss | 20:00 | Defrost recovery period |
| P-57 | C6 Inhibit | 00:00 to 99:00 | 01:00 | mm:ss | 30:00 | Inhibit alarms |
| P-58 | Defrost Over-run | 00:00 to 99:00 | 01:00 | mm:ss | 60:00 | Defrost Over-run |

Parameter table for Probe Tester (Type 2)

| Number | Parameter | Range | Step | Units | Default |
|--------|------------------|-----------------|------|-------|---------|
| P-81 | Channel 1 select | 0 (Off), 1 (ON) | | | 1 |
| P-82 | Channel 2 select | 0 (Off), 1 (ON) | | | 1 |
| P-83 | Channel 3 select | 0 (Off), 1 (ON) | | | 1 |
| P-84 | Channel 4 select | 0 (Off), 1 (ON) | | | 1 |
| P-85 | Channel 5 select | 0 (Off), 1 (ON) | | | 1 |
| P-86 | Channel 6 select | 0 (Off), 1 (ON) | | | 1 |

Units and Probe Type

Change the probe type to: -

| | |
|----------------|------------------------|
| 0 = PTC1000 °C | Range -42 to 128 °C |
| 1 = PTC1000 °F | Range -42 to 128 °C |
| 2 = NTC2000 °C | Range -37 °C to +54 °C |
| 3 = NTC2000 °F | Range -37 °C to +54 °C |
| 4 = NTC2k25 °C | Range -37 °C to +54 °C |
| 5 = NTC2k25 °F | Range -37 °C to +54 °C |



Ensure that all power is switched off before installing or maintaining this product

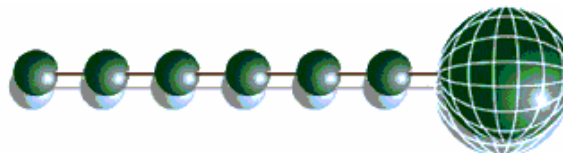

Network Configuration

The final section to set-up is the network address. In all instances, this must be done before the controller is plugged into the site network. The controllers have an auto-initialise function, which will automatically log the device onto the site network. If the wrong address has been entered onto the network, you will have to reset the controller address by setting the address to 00-0, and then re-enter the correct address. (You may have to deregister the wrong address from the home system as well).

To set the controller onto a network you must first connect the controller to a communications module. This is either a: -

- 485 Legacy, or
- IP Futura

485 Legacy module

- This product supports Genus compatible network protocol

Connecting a 485 legacy module to the controller will determine which set up screens are made available. Note: °F values are not supported on a RS485 network system.

| Display | Option |
|---------|--|
| 485t | 485 Network Type |
| 485A | 485 Address/Name |
| gAdd | Show underlying network address assigned to controller |
| rLog | Re-log the controller back onto the network |
| CLrA | Clear the address/name from the controller |
| ESC | Exit network menu. N.B. this option must be selected to save any changes made in this menu |

The 485A option shows a value representing either the name of the controller in a Genus compatible network. If the controller is set for Genus compatible then the value shown is of the form 05-6. This means the controller would try to log onto a Genus compatible network using the name 'RC05-6'.

The following options are only available when the network type is set to Genus compatible.

The gAdd option displays (in hexadecimal format) the underlying network address assigned to the controller when it was logged onto the network.

The rLog option allows the controller to be logged back onto the network with its current name. The 'rLog' message will flash for confirmation. Press the Enter button to execute the command, Up or Down buttons to cancel.

Fast Network Address Reset

The CLrA option will clear out the network address and name in the controller. The 'ClrA' message will flash for confirmation. Press the Enter button to execute the command, Up or Down buttons to cancel.

To enter this mode, hold the Enter, Up and Down buttons together for approximately 3 seconds until the message CLrA appears on the display. CLrA is the first option in the menu consisting of the following options:

| Display | Option |
|---------|--|
| CLrA | Clear the address/name from the controller |
| ESC | Exit Setup mode |

Pressing the Enter button to select the CLrA option will cause the 'CLrA' message to flash for confirmation, if the network type is set to Genus compatible. Press the Enter button to execute the command, Up or Down buttons to cancel. If the network type is not set to Genus compatible then the CLrA message will not flash and the ESC option can be used to exit the menu.



Ensure that all power is switched off before installing or maintaining this product

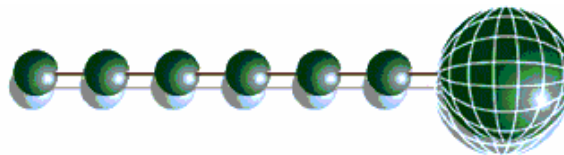

IP Futura module

In an IP system there are two options

- IP-L
- IP-r

IP-L allows you to fix an IP address into the controller, which you would use when you are connecting the controllers onto a customer's local area network. This would allow the customer to view each controller using Internet Explorer

IP-r allows you to give each controller on the system a unique number. This number is then allocated a dynamic IP address by the system DHCP server (such as the RDM Data Director)

IP-L

To configure the communication module for IP-L, set all three rotary switches to zero. The module should then be connected to the controller.

1. nEt. From the function menu you can now select nEt
 - Press enter and the display will show "IP-L", press enter
 - You can now set the address using the table below

| Display | Option |
|---------|--|
| IP-1 | IP Address byte 1 |
| IP-2 | IP Address byte 2 |
| IP-3 | IP Address byte 3 |
| IP-4 | IP Address byte 4 |
| nL | Network Mask Length |
| gt-1 | Gateway Address byte 1 |
| gt-2 | Gateway Address byte 2 |
| gt-3 | Gateway Address byte 3 |
| gt-4 | Gateway Address byte 4 |
| ESC | Exit network menu. N.B. this option must be selected to save any changes made in this menu |

IP-r

To configure the communication module for IP-r, set the three rotary switches to give each controller a unique identifier. The module should then be connected to the controller and the network.

The green network LED on the controller will flash until it has been logged on to the network. The Green network LED will remain permanently on while it is on-line.



Ensure that all power is switched off before installing or maintaining this product

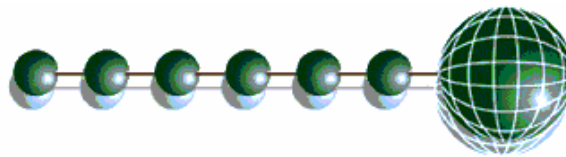

Normal Operation

During normal operation, the controller will display "on" if there are no alarms and no defrost actions. If the Monitor is on a network and on-line, the green network LED will be on.



Defrost

If a defrost signal is received (switched resistor) the Monitor will indicate which channel is in the defrost state and the amber defrost LED will come on. All alarms on that channel will be inhibited during the time the resistor is switched in. Alarms will continue to be inhibited for the duration of the recovery period after the resistor is switched out. (Note: if the defrost over-run parameter is set to 00:00, the channel will remain in the defrost state until the resistor is removed).

When any channel is in a defrost state, the defrost relay is energised.

Defrost Over-run

A defrost over-run period can be set into the monitor on a per channel basis, if the defrost exceeds this period, the channel will revert to normal operations. Setting this parameter to 00:00 inhibits this function.

Faults

If a fault is detected, the Monitor will indicate the fault on the display and the red fault LED will come

Network

The Network green LED flashes if the controller goes off-line or loses its given address.

Probe Offset

Each probe can be offset by up to ± 10 °C to compensate for long cable runs.

Inhibit Alarms

Probe alarms can be inhibited on a probe-by-probe basis by selecting the desired channel parameter in the set up mode and pressing "enter". This state can be changed back by repeating the above procedure. There is also a timeout function on the alarm inhibit (see parameter table for timeout values)

Note. If the channel temperature is **not** within the set alarm limits before the inhibit timeout has elapsed, the channel will stay inhibited and **not** give an alarm.

--XXX Use this feature with caution XXX--



Ensure that all power is switched off before installing or maintaining this product

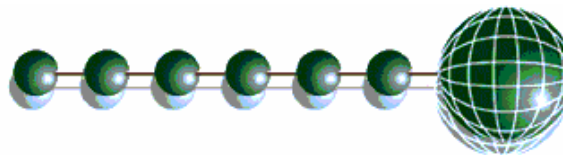

Alarm Relay Action:

The alarm relay is a normally closed contact that allows for an alarm action if power to the controller is lost. This relay will normally be energised (no alarm) and be de-energised when an alarm occurs (after the alarm delay time-out)

The table below shows the Alarm relay action

| State | Alarm Delay | Alarm Relay |
|--------------------|----------------------|-------------|
| Probe Fault | Fixed 10 Seconds | ✗ |
| Channel Under temp | Variable (parameter) | ✓ |
| Channel Over temp | Variable (parameter) | ✓ |
| Plant Fault | Variable (parameter) | ✓ |

Remote Relays

Relays 3,4 and 5 can be used by "The Data Builder" as remote relays. See the user guide for "The Data Builder" for further information.

Viewing

Apart from setting up the controller, you can also view the status of the inputs and outputs.

1. IO. View Inputs / Outputs and States
 - a. From the function menu, select "IO", press enter
 - b. You can now scroll through the IO tables as set out below. The tables you view will depend on the controller type configuration.

Input/Output table for Monitor (Type 1)

| Number | IO | Range | Step | Units |
|--------|---------------|-------------------|------|-------|
| I-01 | Probe 1 | -42 to 128 °C | 0.1 | Deg |
| I-02 | Probe 2 | -42 to 128 °C | 0.1 | Deg |
| I-03 | Probe 3 | -42 to 128 °C | 0.1 | Deg |
| I-04 | Probe 4 | -42 to 128 °C | 0.1 | Deg |
| I-05 | Probe 5 | -42 to 128 °C | 0.1 | Deg |
| I-06 | Probe 6 | -42 to 128 °C | 0.1 | Deg |
| I-11 | Defrost 1 | 0 (Off), 1 (On) | | |
| I-12 | Defrost 2 | 0 (Off), 1 (On) | | |
| I-13 | Defrost 3 | 0 (Off), 1 (On) | | |
| I-14 | Defrost 4 | 0 (Off), 1 (On) | | |
| I-15 | Defrost 5 | 0 (Off), 1 (On) | | |
| I-16 | Defrost 6 | 0 (Off), 1 (On) | | |
| I-21 | Plant Fault 1 | 0 (Ok), 1 (Alarm) | | |
| I-22 | Plant Fault 2 | 0 (Ok), 1 (Alarm) | | |
| I-23 | Plant Fault 3 | 0 (Ok), 1 (Alarm) | | |
| I-24 | Plant Fault 4 | 0 (Ok), 1 (Alarm) | | |
| I-25 | Plant Fault 5 | 0 (Ok), 1 (Alarm) | | |
| I-26 | Plant Fault 6 | 0 (Ok), 1 (Alarm) | | |
| O-01 | Alarm Relay | 0 (Ok), 1 (Alarm) | | |
| O-11 | Defrost Relay | 0 (Off), 1 (On) | | |
| O-21 | Relay 3 | 0 (Off), 1 (On) | | |
| O-22 | Relay 4 | 0 (Off), 1 (On) | | |
| O-23 | Relay 5 | 0 (Off), 1 (On) | | |



Ensure that all power is switched off before installing or maintaining this product

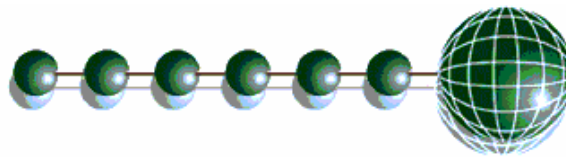

Input/Output table for Monitor (Type 1) cont.....

| Number | IO | Range |
|--------|-----------------|--|
| S-01 | Control State 1 | 0 (Off) 1 (Stabilise), 2 (Normal), 3 (Defrost), 4 (Recovery), 5 (Alarm), 6 (Inhibit) |
| S-02 | Control State 2 | 0 (Off) 1 (Stabilise), 2 (Normal), 3 (Defrost), 4 (Recovery), 5 (Alarm), 6 (Inhibit) |
| S-03 | Control State 3 | 0 (Off) 1 (Stabilise), 2 (Normal), 3 (Defrost), 4 (Recovery), 5 (Alarm), 6 (Inhibit) |
| S-04 | Control State 4 | 0 (Off) 1 (Stabilise), 2 (Normal), 3 (Defrost), 4 (Recovery), 5 (Alarm), 6 (Inhibit) |
| S-05 | Control State 5 | 0 (Off) 1 (Stabilise), 2 (Normal), 3 (Defrost), 4 (Recovery), 5 (Alarm), 6 (Inhibit) |
| S-06 | Control State 6 | 0 (Off) 1 (Stabilise), 2 (Normal), 3 (Defrost), 4 (Recovery), 5 (Alarm), 6 (Inhibit) |



Ensure that all power is switched off before installing or maintaining this product

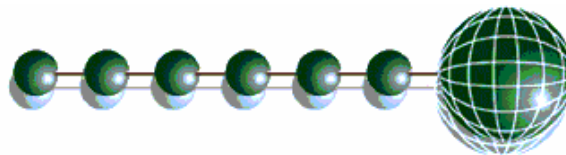

Input/Output table for Probe Tester (Type 2)

| Number | IO | Range | Step | Units |
|--------|---------|---------------|------|-------|
| I-01 | Probe 1 | -42 to 128 °C | 0.1 | Deg |
| I-02 | Probe 2 | -42 to 128 °C | 0.1 | Deg |
| I-03 | Probe 3 | -42 to 128 °C | 0.1 | Deg |
| I-04 | Probe 4 | -42 to 128 °C | 0.1 | Deg |
| I-05 | Probe 5 | -42 to 128 °C | 0.1 | Deg |
| I-06 | Probe 6 | -42 to 128 °C | 0.1 | Deg |

Display Messages

The following messages can appear on the Mercury display.

| Display | System status |
|---------|---------------------------------|
| on | Controller On |
| Prb1 | Probe 1 Fault |
| Prb2 | Probe 2 Fault |
| Prb3 | Probe 3 Fault |
| Prb4 | Probe 4 Fault |
| Prb5 | Probe 5 Fault |
| Prb6 | Probe 6 Fault |
| Pd 1 | Control State in Recovery |
| Pd 2 | Control State in Recovery |
| Pd 3 | Control State in Recovery |
| Pd 4 | Control State in Recovery |
| Pd 5 | Control State in Recovery |
| Pd 6 | Control State in Recovery |
| deF1 | Control Sate in Defrost |
| deF2 | Control Sate in Defrost |
| deF3 | Control Sate in Defrost |
| deF4 | Control Sate in Defrost |
| deF5 | Control Sate in Defrost |
| deF6 | Control Sate in Defrost |
| Inh1 | Inhibit alarms for probe 1 |
| Inh2 | Inhibit alarms for probe 2 |
| Inh3 | Inhibit alarms for probe 3 |
| Inh4 | Inhibit alarms for probe 4 |
| Inh5 | Inhibit alarms for probe 5 |
| Inh6 | Inhibit alarms for probe 6 |
| Ot 1 | Over Temperature Alarm probe 1 |
| Ot 2 | Over Temperature Alarm probe 2 |
| Ot 3 | Over Temperature Alarm probe 3 |
| Ot 4 | Over Temperature Alarm probe 4 |
| Ot 5 | Over Temperature Alarm probe 5 |
| Ot 6 | Over Temperature Alarm probe 6 |
| Ut 1 | Under Temperature Alarm probe 1 |
| Ut 2 | Under Temperature Alarm probe 2 |
| Ut 3 | Under Temperature Alarm probe 3 |
| Ut 4 | Under Temperature Alarm probe 4 |



Ensure that all power is switched off before installing or maintaining this product

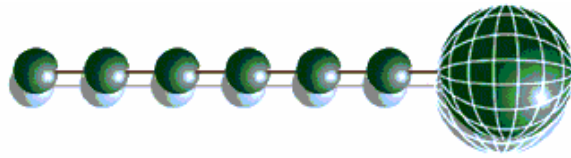

| | |
|------|---------------------------------|
| Ut 5 | Under Temperature Alarm probe 5 |
| Ut 6 | Under Temperature Alarm probe 6 |
| PLt1 | Plant fault 1 |
| PLt2 | Plant fault 2 |
| PLt3 | Plant fault 3 |
| PLt4 | Plant fault 4 |
| PLt5 | Plant fault 5 |
| PLt6 | Plant fault 6 |



Ensure that all power is switched off before installing or maintaining this product

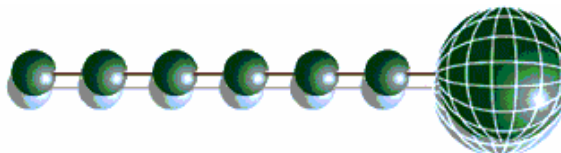

Network Alarms

The table below shows the text and associated type number that is sent to the system "front end". The type number is normally used to provide different alarm actions.

| Alarm text | Type |
|-----------------------------|------|
| Probe 1 Faulty | 6 |
| Probe 2 Faulty | 8 |
| Probe 3 Faulty | 11 |
| Probe 4 Faulty | 14 |
| Probe 5 Faulty | 17 |
| Probe 6 Faulty | 6 |
| | |
| Channel 1 over temperature | 4 |
| Channel 2 over temperature | 9 |
| Channel 3 over temperature | 12 |
| Channel 4 over temperature | 15 |
| Channel 5 over temperature | 18 |
| Channel 6 over temperature | 4 |
| | |
| Channel 1 under temperature | 5 |
| Channel 2 under temperature | 10 |
| Channel 3 under temperature | 13 |
| Channel 4 under temperature | 16 |
| Channel 5 under temperature | 19 |
| Channel 6 under temperature | 5 |
| | |
| Plant 1 Fault | 6 |
| Plant 2 Fault | 8 |
| Plant 3 Fault | 11 |
| Plant 4 Fault | 14 |
| Plant 5 Fault | 17 |
| Plant 6 Fault | 6 |
| | |
| Channel 1 defrost overrun | 20 |
| Channel 2 defrost overrun | 20 |
| Channel 3 defrost overrun | 20 |
| Channel 4 defrost overrun | 20 |
| Channel 5 defrost overrun | 20 |
| Channel 6 defrost overrun | 20 |



Ensure that all power is switched off before installing or maintaining this product

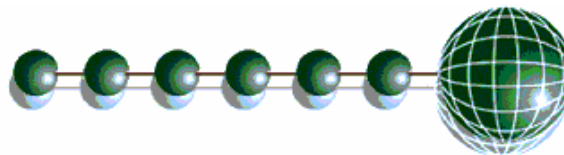

Specification

General

Power requirements:

| | |
|------------------------------|--|
| Supply Voltage Range: | 100 - 240 Vac $\pm 10\%$ |
| Supply Frequency: | 50 - 60 Hz $\pm 10\%$ |
| Maximum supply current: | <1 Amp |
| Typical supply current: | <0.5 Amp |
| Operating temperature range: | +5°C to +50°C |
| Operating Humidity: | 80% maximum |
| Storage temperature range: | -20°C to +65°C |
| Environmental: | Indoor use at altitudes up to 2000m, Pollution Degree 1, Installation Category II. |
| Size: | Voltage fluctuations not to exceed $\pm 10\%$ of nominal voltage 110mm (W) x 60mm (H) x 100mm (D) |
| Weight: | 150 Grams |
| Safety: | EN61010 |
| EMC: | EN61326; 1997 +Amdt. A1; 1998 |
| Ventilation: | There is no requirement for forced cooling ventilation |
| Class 2 Insulation: | No protective Earth is required and none should be fitted. |

The host equipment must provide a suitable external over-current protection device such as:

| | |
|---------|---|
| Fuse: | 1A, 240 Vac Antisurge (T) HRC conforming to IEC 60127 |
| Or MCB: | 1A, 240 Vac Type C conforming to BS EN 60898 |

The host equipment must provide adequate protection against contact to hazardous live parts.

Relays

| | |
|----------------------|--------------------------|
| Max current relay 1: | 6A (non inductive) |
| Max Voltage relay 1: | 260Vac (external supply) |
| Exclusive common: | |



Warning:

Relays 4 and 5 outputs have hazardous voltages (Supply input voltage potential).

Inputs:

| | |
|-------------------|---|
| Input resistance: | 3.01K Ohms (for PTC or NTC type probes) |
| Input type | PT1000 (820 Ohm resistor for defrost input) NTC2000 (590 Ohm resistor for defrost inputs) NTC2k25 (590 Ohm resistor for defrost inputs) |

Comms: RS232 with flow control



Ensure that all power is switched off before installing or maintaining this product

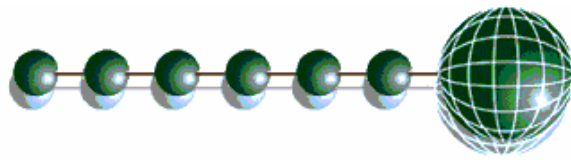

Installation:

Panel Cut-out:

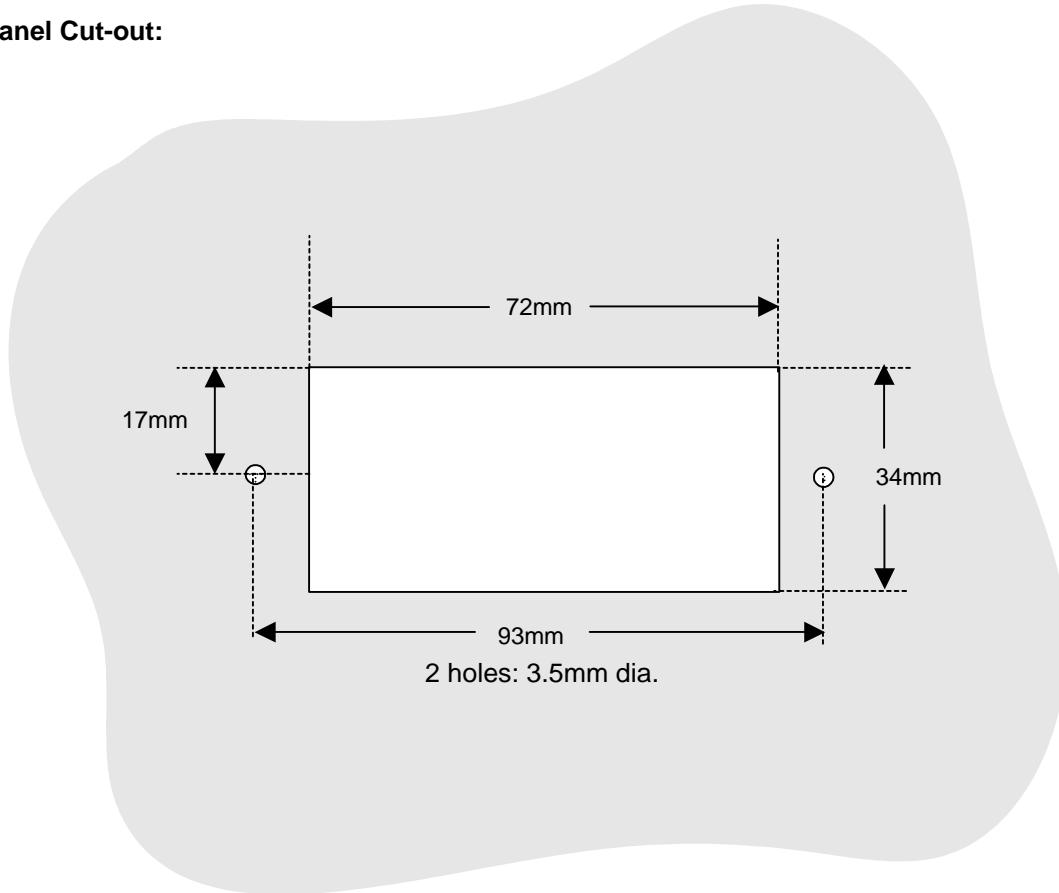

Fixing:

The controller can be fixed either by 2 X M3 screws from the rear or by the plastic retaining device (PR0329), obtainable from RDM.

Clearances:

The controller must have 5mm clearance above the top and below bottom, and 25mm clearance from the sides. Clearance at the rear is dependant on the wiring.
There is no requirement for forced cooling ventilation



Ensure that all power is switched off before installing or maintaining this product

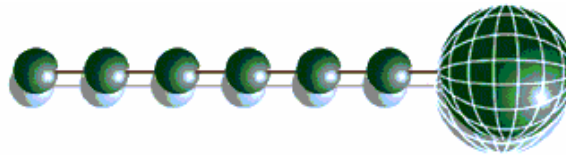

Wiring:

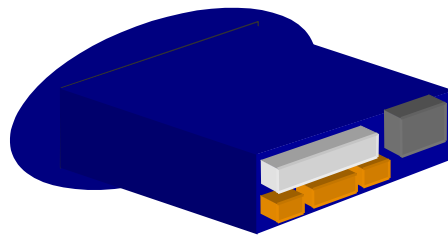

Communications socket

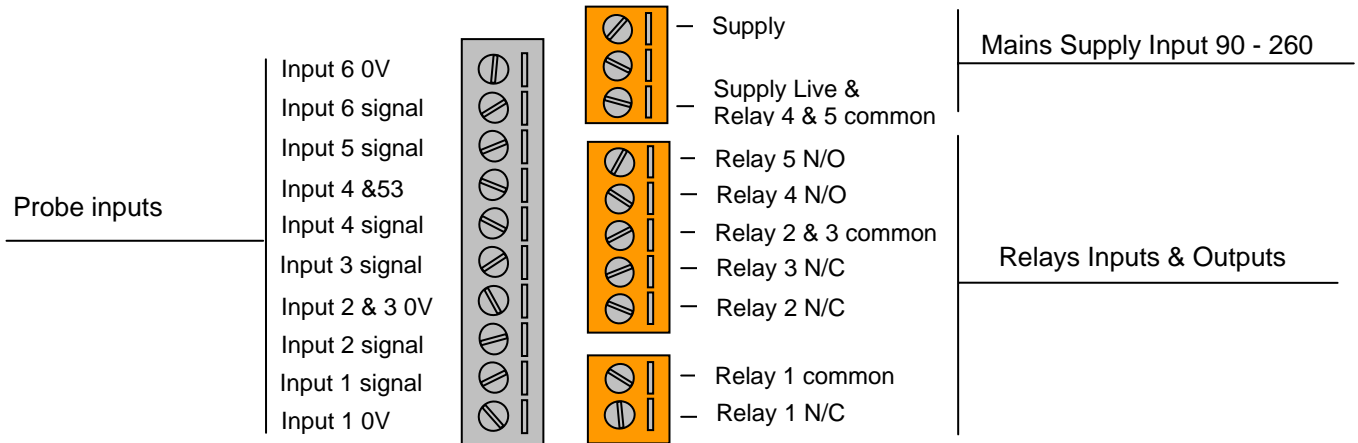

Relay 4 and 5 N/O are fed from the supply input

Note:

Suitable mechanical restraints on the wiring to the controller may be required; dependant on cable types, to prevent undue stress or distortion on the controller connectors.

Defrost Signal Resistors:

Example of 820-Ohm resistor fitted on Probe 2

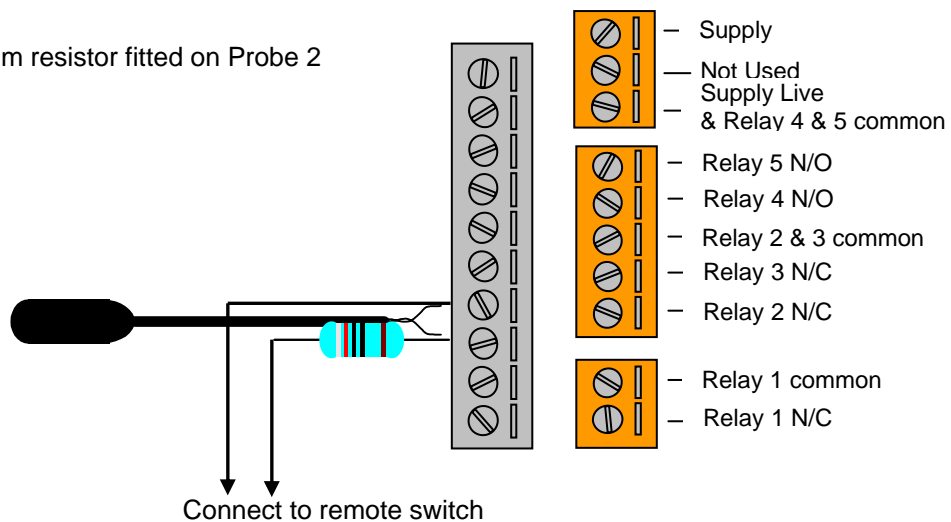

Ensure that all power is switched off before installing or maintaining this product

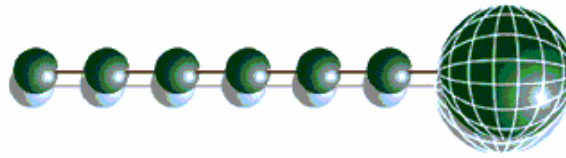

Fuse:

The host equipment must provide a suitable external over-current protection device such as: -

Fuse: 1A, 240 Vac Antisurge (T) HRC conforming to IEC 60127
Or MCB: 1A, 240 Vac Type C conforming to BS EN 60898

Cleaning:

Do not wet the controller when cleaning. Clean the front by wiping with slightly dampened lint free cloth.

Please note: The specifications of the product detailed on this set up guide may change without notice. RDM Ltd shall not be liable for errors or for incidental or consequential damages, directly or indirectly, in connection with the furnishing, performance or misuse of this product or document.



Ensure that all power is switched off before installing or maintaining this product