

Mercury 11-10CV Dry Cooler Controller Installation Guide

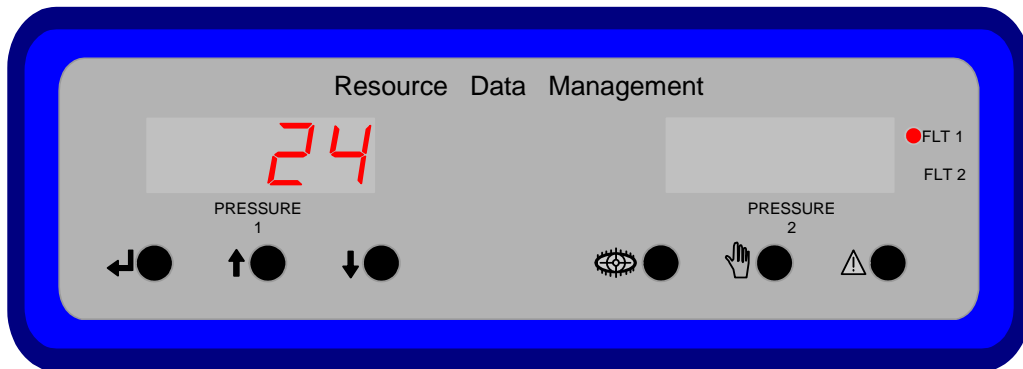

Product Numbers: -

PR0274 Mains

PR0275 Low Voltage

PR0276 Mains with Remote Display

PR0277 Low Voltage with remote Display



Ensure that all power is switched off before installing or maintaining this product

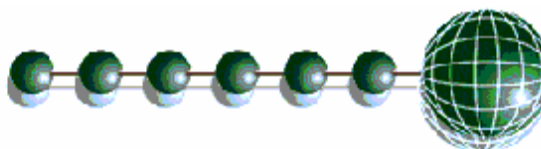

Contents:

THE MERCURY RANGE	3
Description	3
Configuration	3
Front Panel: -	4
Section Display	4
Front Panel Buttons	4
Connections (Mains Version: PR0274/0276).....	5
Connections (Low Voltage Version: PR0275/0277).....	6
Setting up the controller	7
Set-up Mode.....	7
Set-up through front buttons	7
Set-up Menu.....	7
Recommended set-up method	7
rtc. Real time clock (This will automatically synchronise on network systems)	7
type. Set/view controller type	8
Set/View Units	8
PArA. Set/view parameters	8
Network Configuration	9
IP Futura module.....	9
IP-L	9
IP-r.....	9
Parameter Table.....	10
Section Stage Outputs:	12
Stage Inputs	12
Operation	13
T2 Control Graph	14
Configuration Example: -	15
Connection Table for the above example:	15
Viewing	18
Inputs and Outputs.....	18
Input/Output Table.....	18
Viewing Alarms	19
Quickview	20
Override	20
Standby Mode	20
Display Messages.....	21
Alarm Display Messages	21
Network Alarms	22
Specification	23
Power requirements for PR0274 and PR0276:	23
Power requirements for PR0275 and PR0277:	23
General	23
Inputs:	23
Analogue Output:	23
Relay Ratings.....	24
REVISION HISTORY.....	25



Ensure that all power is switched off before installing or maintaining this product

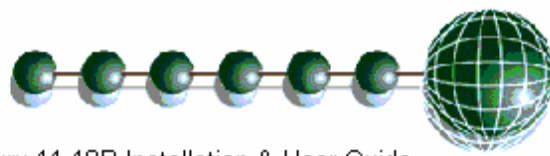

The Mercury Range

From Resource Data Management

This documentation refers to the controller Mercury 11-10CV

Description

The Mercury 11-10CV is a versatile controller intended for secondary refrigeration Dry-Cooler control. It has 10 relay outputs that are configurable for cooling devices such as fans for the cooler and pumps for the Water system. Control of the relays is by temperature sensing on the control probes. There is also an analogue output for variable control. The 10 inputs can be assigned for various inputs (see parameter table) or general alarms. There are two 4-20mA inputs for monitoring 2 pressure transducers.

The control is a "Fuzzy logic" based algorithm, giving enhanced control. The algorithm also reduces the number of input parameters required for control; only a target temperature is needed. There is a speed-up or slow-down feature to trim the control to different systems.

Like all Mercury controllers, the 11-10CV has a serial output that can connect directly to a PC for quick set-up (PC running RDM Communicator application) or to one of RDMs' network modules.

A second thermostat function can be used for "heat reclaim" systems.

Configuration

The controller has 1 configuration option: - (see [Set/View Type](#) for changing the type)

Display value	Type
1	Dry Cooler (Using Temperature for control)



Ensure that all power is switched off before installing or maintaining this product

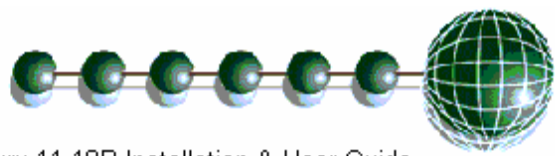

Front Panel: -

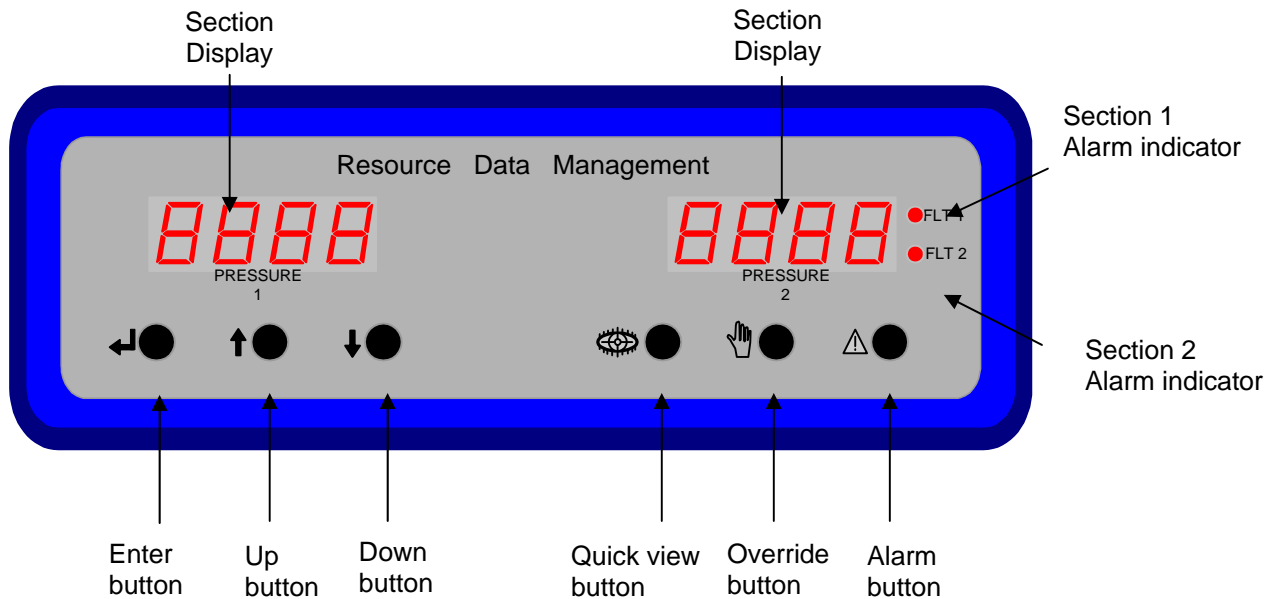

Section Display

4 character display shows the Control temperature and the number of outputs energised.

In set-up mode, displays the set-up menu items

In quick view mode, indicates the target temperature

In alarm view mode, indicates the alarm number

Suction and discharge pressures can be displayed momentarily by pressing the override button

Front Panel Buttons

Enter Button: - Used to enter menu items.

Up Button: - Used to scroll up

Down Button: - Used to scroll down

Quick View Button: - Used to view the target temperature (See [Quickview](#) section)
In "alarm view" mode, used to view the alarm occurred

Override Button: - Used with the "Enter" button, to go into the override mode. (See [Override](#) section)

Alarm Button: - Used to enter the "alarm view" mode. (See [View Alarms](#) section)



Ensure that all power is switched off before installing or maintaining this product

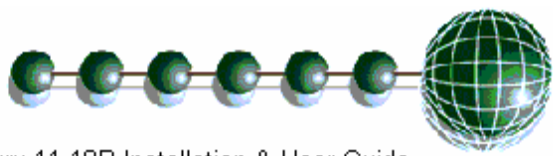

Connections (Mains Version: PR0274/0276)

All connections are made to the back of the controller. The diagram below shows the connection detail. Inputs and outputs are assigned according to the chosen configuration.

RELAYS

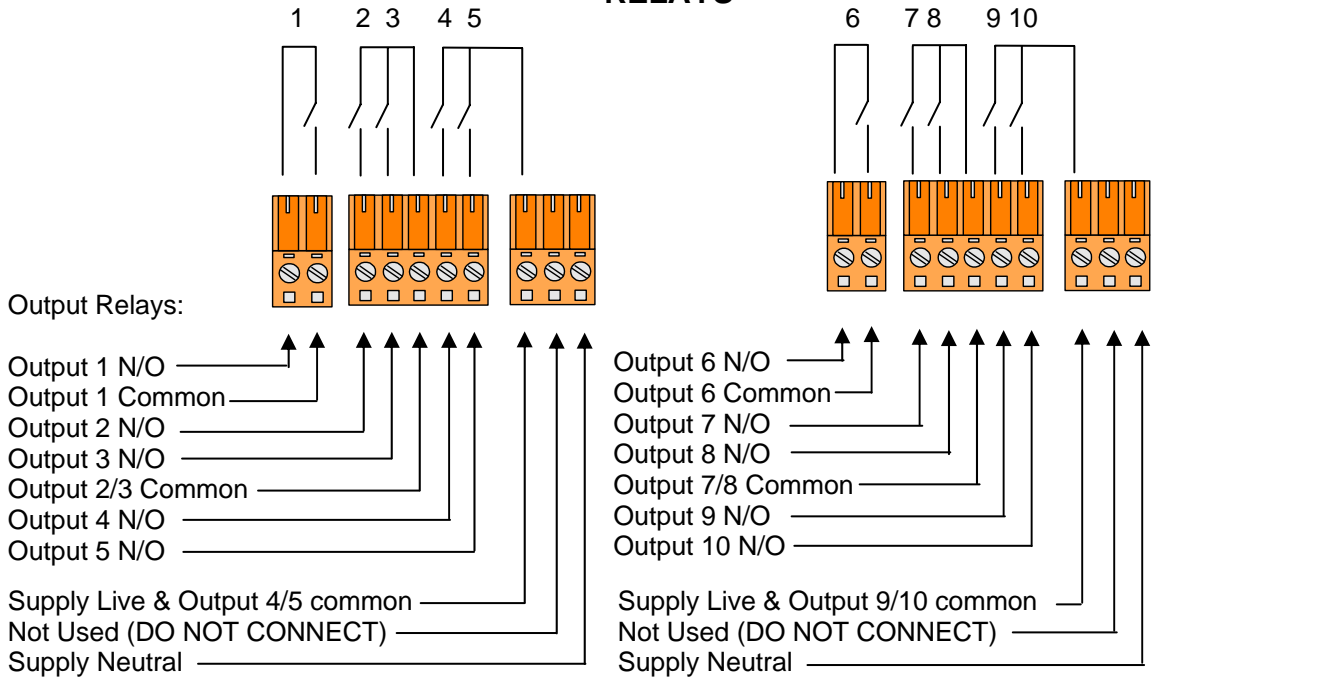

INPUTS

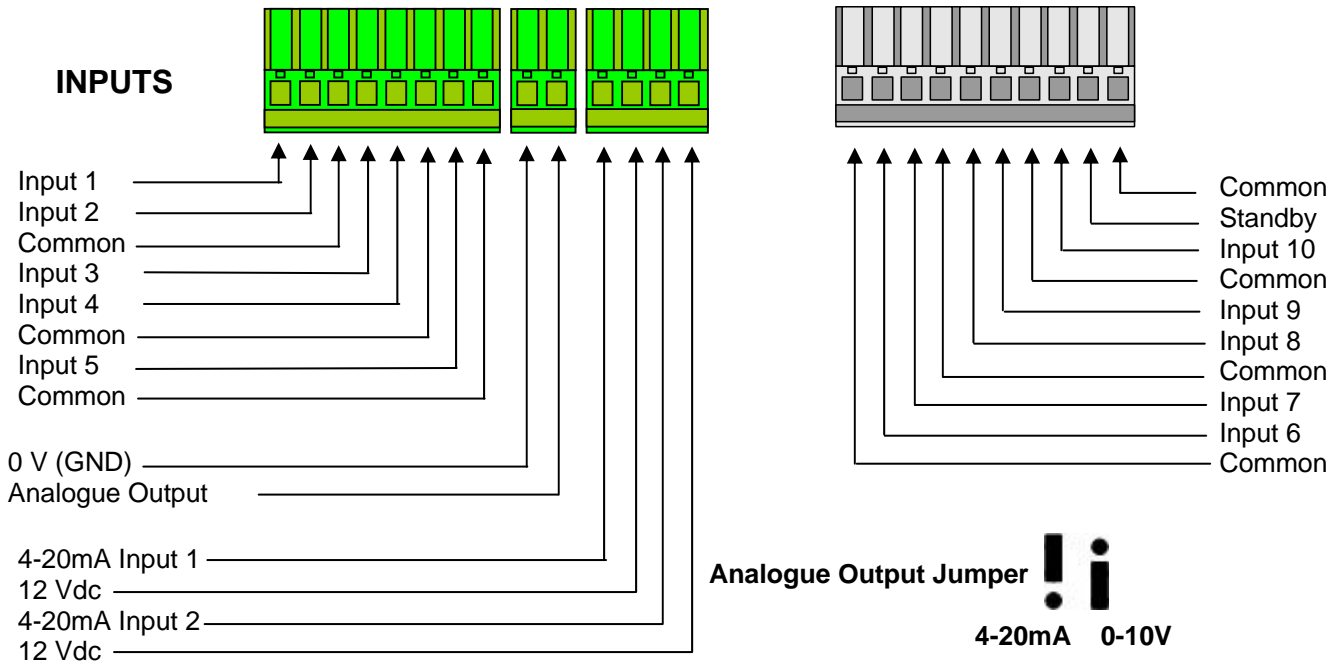

Probe type is PT1000 only.

Both Supplies must be connected. Do not connect an earth.



Ensure that all power is switched off before installing or maintaining this product

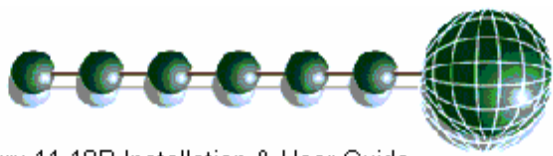

Connections (Low Voltage Version: PR0275/0277)

All connections are made to the back of the controller. The diagram below shows the connection detail. Inputs and outputs are assigned according to the chosen configuration.

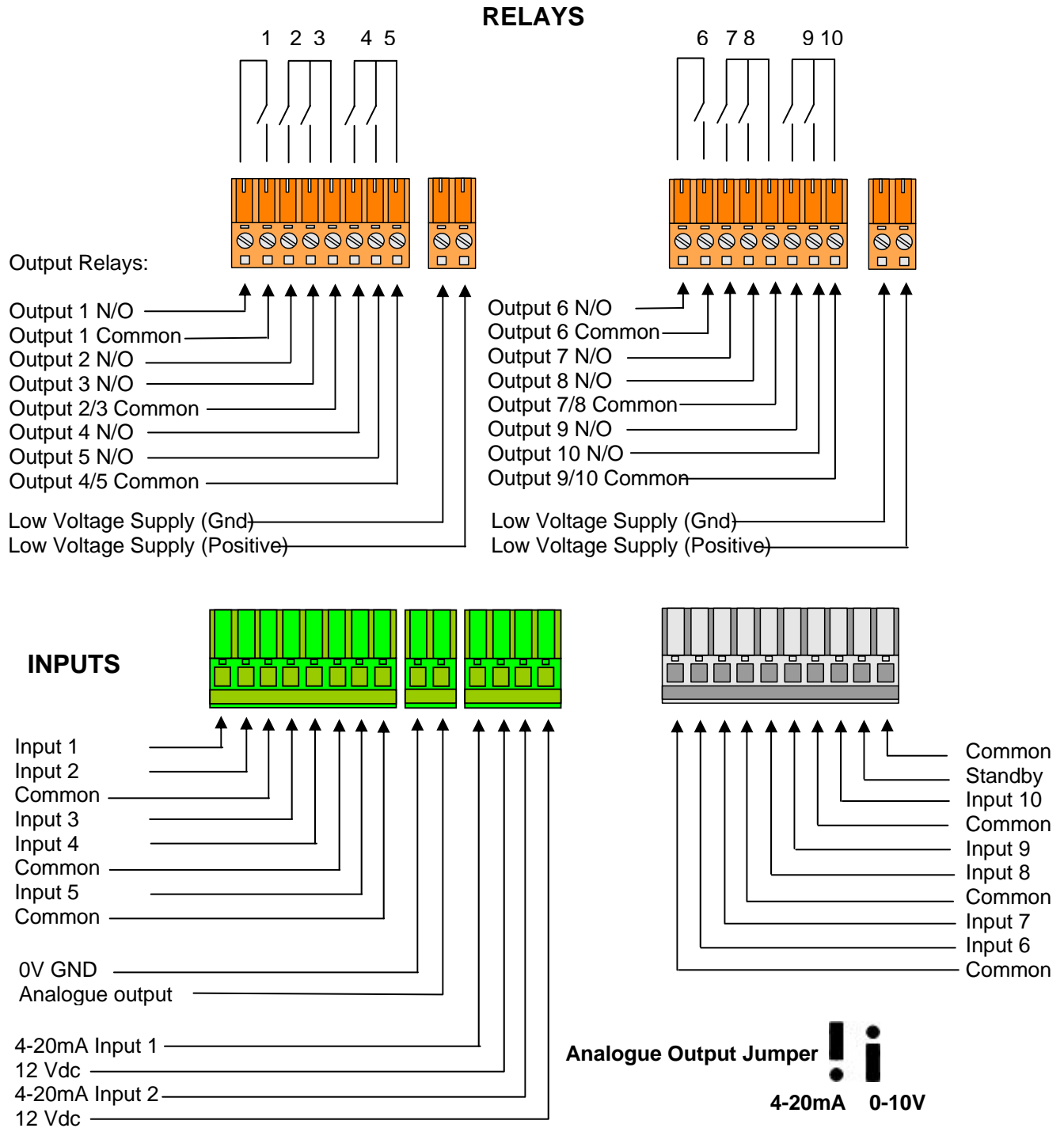

Probe input is PT1000 only.

Both Supplies must be connected.

Low Voltage Supply (Gnd) can be Earthed if required



Ensure that all power is switched off before installing or maintaining this product

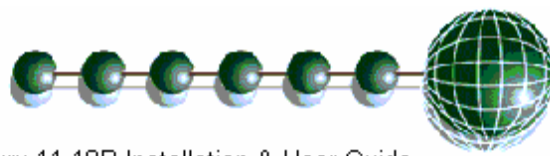

Setting up the controller

Set-up access to the controller can be achieved several ways

- Through the front mounted buttons
- Direct access by PC or palm top into the rear comms port. This requires a software package available on the RDM website (Communicator)
- Through legacy front end panels on 485 networks
- Through the RDM Data Director.

Set-up Mode

Set-up through front buttons

To enter set-up mode, hold the Enter and Down buttons together for approximately 3 seconds until the message “Ent” appears on the display. Now press the Enter button again to enter the function menu. IO will be displayed. Scroll up or down to go through the list.

Set-up Menu

LH Display	RH Display	Option	Menu Item seen in type:	Explained in Paragraph
IO		View Input/Output States	All types	View Input/Output States
PArA		Set/view Parameters	All types	Set/view parameters
Unit		Set/View units	All types	Set/View Units
TyPE		Set/View Controller Type	All types	Set/view product type
rtc		Set/view Clock (rtc = Real Time Clock)	All types	Real Time Clock
nEt		Set/view network configuration	All types	Network Configuration
SoFt		View software version	All types	
ESC		Exit set-up mode		

Recommended set-up method

If you are not connecting to a network and want to set up the controller through the buttons we recommend you use the following order from the function menu.

rtc. Real time clock (This will automatically synchronise on network systems)

1. Use the up or down buttons to scroll through the display until the display reads “rtc”
2. Press enter. The display will show “t-1”. Press enter again
3. Scroll hours up or down (0 – 23) press enter
4. Use up button to select “t-2”, press enter
5. Scroll minutes up or down (0 – 59) press enter
6. Repeat for t-3 (seconds 0 – 59)
7. Repeat for t-4 (Days up to 31)
8. Repeat for t-5 (months up to 12)
9. Repeat for t-6 (Year up to 99)
10. Use up button to display “ESC”, press enter to display “rtc”

Time clock is now set



Ensure that all power is switched off before installing or maintaining this product

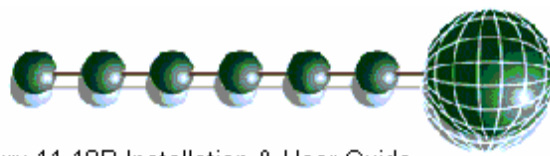

type. Set/view controller type

1. From the function menu scroll to "type", press enter
2. Use the up/down buttons to scroll through the type values. (See [configuration](#) on page 4)
3. Press enter.

The controller will reset with the selected type now programmed.

Set/View Units

This option allows the user to set the pressure units to either PSI or BAR

- 0 = PSI (default)
- 1 = BAR

Once activated, the controller parameters and display units will be in the set units. Note. If using the controller on a Genus system, bar units will not display on the system front-end.

The three previous setup operations can only be achieved at the controller through the menu system, or by using "Communicator" linked directly to the controller.

PArA. Set/view parameters

(We recommend setting parameters from "Communicator" or the network front end such as "Data Manager")

1. From the function menu scroll to PArA
2. Pressing Enter while PArA is displayed will enter the parameter menu.

The first parameter option will be displayed as P-01. Pressing the Up or Down button will present the other parameter options P-02, P-03 etc. See the parameter list below to find what parameter number corresponds to which actual parameter.

Pressing the Enter button will show the current value of the selected parameter. Press Up or Down to modify the value and press Enter again to save the value. The parameter list number will be displayed again. Two other options are present in the parameter menu – dFLt and ESC. Selecting ESC will exit the parameter set-up mode. Selecting dFLt will reset all parameters back to the default values for the current controller type.

See [Parameter Tables](#) for values



Ensure that all power is switched off before installing or maintaining this product

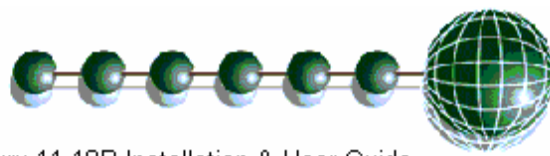

Network Configuration

The final section to set-up is the network address. In all instances, this must be done before the controller is plugged into the site network. The controllers have an auto-initialise function, which will automatically log the device onto the site network. If the wrong address has been entered onto the network, you will have to reset the controller address by setting the address to 00-0, and then re-enter the correct address. (You may have to deregister the wrong address from the home system as well).

To set the controller onto a network you must first connect the controller to a communications module. Use either a port on a Mercury Hub or an IP Futura module.

IP Futura module

In an IP system there are two options

- IP-L
- IP-r

IP-L allows you to fix an IP address into the controller, which you would use when you are connecting the controllers onto a customer's local area network. This would allow the customer to view each controller using Internet Explorer

IP-r (normally used mode) allows you to give each controller on the system a unique number. This number is then allocated a dynamic IP address by the system DHCP server (such as the RDM Data Manager)

IP-L

To configure the communication module for IP-L, set all three rotary switches to zero. The module should then be connected to the controller.

1. nEt. From the function menu you can now select nEt
 - Press enter and the display will show "IP-L", press enter
 - You can now set the address using the table below

Display	Option
IP-1	IP Address byte 1
IP-2	IP Address byte 2
IP-3	IP Address byte 3
IP-4	IP Address byte 4
nL	Network Mask Length
gt-1	Gateway Address byte 1
gt-2	Gateway Address byte 2
gt-3	Gateway Address byte 3
gt-4	Gateway Address byte 4
ESC	Exit network menu. N.B. this option must be selected to save any changes made in this menu

IP-r

To configure the communication module for IP-r, set the three rotary switches to give each controller a unique identifier. The module should then be connected to the controller and the network.

- From the function menu select nEt
- Press enter and the display will show "IP-r", press enter
- You can now view the address given by the DHCP server



Ensure that all power is switched off before installing or maintaining this product

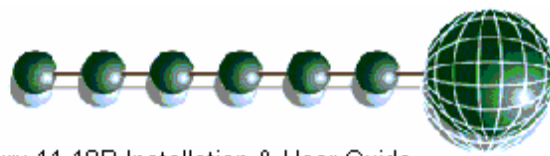

Parameter Table

Number	Parameter	Range	Step	Units	Dft	Comments
P-01	Dry Cooler Target temperature	-50 to 70	1	°C	34	Controlled by bringing fans on/off
P-02	DC Target Diff Above	0 to 30	1	°C	1	
P-03	DC Target Diff Below	0 to 30	1	°C	1	
P-04	Target offset	-50 to 70		°C	5	Used when "set target" input is activated, both targets are changed
P-05	Control Weight	0 to 100	1	%	50	Bias to the first DC probe selected
P-06	Display Weight	0 to 100	1	%	50	Bias to the first DC probe selected
P-07	Ambient moves Target (DC & Valve)	0 = Off 1 = On	1		0	This requires an input selected as "Ambient"
P-08	Ambient Setpoint	-50 to 70	1	°C	10	Move target temperature when below this ambient. Move in proportion, 1 below, move target 1 up. Both targets are changed
P-09	Offset Maximum	0 to 30	1	°C	5	Move the target setpoint up proportionally until this offset is reached. Or move by this amount when "Move target is present)
P-10	DC Response On speed	1 - 15	1		5	1 = slowest 15 = fastest
P-11	DC Response Off speed	1 - 15	1		5	1 = slowest 15 = fastest
P-12	Valve Target Temperature (Pump output)	-50 to 70	1	°C	32	Uses the Pump Flow Temperature, and controls the variable output (Proportional valve)
P-13	Valve Response On	0 to 15	1		10	0 = slowest 15 = fastest
P-14	Valve Response Off	0 to 15	1		10	0 = slowest 15 = fastest
P-15	Cycle Pumps	0 to 10 0 = Off, Pump fail will not change pump.	1	Days	0	Set this parameter to 1 to 10 if more than 1 pump is being used.
P-16	Minimum Staging delay	00:00 to 05:00		mins/sec	00:15	Minimum delay between stage starts
P-17	Pressure Transducer 1	0 = off 1 = Log 2 = Log & Alarm	1		0	
P-18	Pressure Transducer 2	0 = off 1 = Log 2 = Log & Alarm	1		0	



Ensure that all power is switched off before installing or maintaining this product

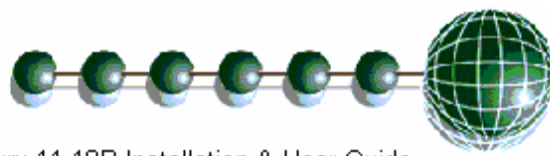

Mercury 11-10P Installation & User Guide

P-19	Transducer 1 Span*	-50 - 560	1	PSI	200	Set up transducer range
P-20	Transducer 1 Offset*	-50 - 560	1	PSI	0	Setup value below 0
P-21	Transducer 2 Span*	-50 - 500	1	PSI	200	Set up transducer range
P-22	Transducer 2 Offset*	-50 - 500	1	PSI	0	Setup value below 0
P-30	DC OT Alarm	-42 - 60		°C	40	DC Control OT temp alarm
P-31	DC UT Alarm	-42 - 60		°C	20	DC Control UT temp alarm
P-32	Valve OT Alarm	-42 - 60		°C	40	Valve control probe OT alarm
P-33	Valve UT Alarm	-42 - 60		°C	20	Valve control Probe UT alarm
P-34	Probe OT Alarm	-42 - 60		°C	40	For inputs that been selected as probe + Alarm (PrbAlm)
P-35	Probe UT Alarm	-42 - 60		°C	5	
P-36	Transducer 1 HP Alarm	-50 - 560	1	PSI	60	Monitor with alarm
P-37	Transducer 1 LP Alarm	-50 - 560	1	PSI	4	Monitor with alarm
P-38	Transducer 2 HP Alarm	-50 - 560	1	PSI	260	Monitor with alarm
P-39	Transducer 2 LP Alarm	-50 - 560	1	PSI	100	Monitor with alarm
P-40	Fault Delay	00:00 to 60:00	1	mins/sec	00:10	
P-41	General Fault Delay	00:00 to 60:00	1	mins/sec	00:10	
P-42	Probe Alarm Delay	00:00 to 99:00	1	mins/sec	05:00	
P-43	Pressure Alarm delay	00:00 to 99:00	1	mins/sec	01:00	
P-50 ↓ P-59	Stage 1 Output Type ↓ Stage 10 Output Type	(0) None, (1) Unused, (2) Inverter (3) Fan (4) Pump	1		0	None ends the config Unused skips a relay
P-70 ↓ P-79	Stage 1 Input Type ↓ Stage 10 Input Type	(0) Unused (1) FanN/O (2) FanN/C (3) DC In (4) DC Out (5) Valve (6) Amb (7) PrbLog (8) PrbAlm (9) PN/O (10)PN/C (11) GN/O (12) GN/C (13) SN/O (14) SN/C	1		0	No action Fan Fail N/O Fan Fail N/C Dry Cooler In Probe Dry Cooler Out Probe Valve probe Ambient probe Logging Probe Log probe + alarm Pump Fail N/O Pump Fail N/C General Input N/O General Input N/C Set target N/O Set target N/C
dFLt	Restore Default Settings					

* Span and Offset allows for the full range of the transducer to be used by the controller.

Span is the full range of the transducer

Offset is the value below zero.

E.g. Danfoss AKS 33 with range: -1 bar to 12 bar
Span would be 190 (13 bar)
Offset would be -15 (-1 bar)



Ensure that all power is switched off before installing or maintaining this product

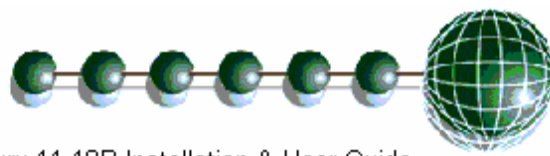

Section Stage Outputs:

Section stages can be set up as: - None, Unused, Inverter, Fan or Pump. These parameters determine which relay is assigned to the section outputs.

Output Stages	Description	Comments
None	Use this option to end the number of stages in the controller	
Unused	Use this option to skip a relay output within a stage	
Inv	Analogue output for Fan control	If this option is used, the proportional valve cannot be used.
Fan	Use this option to assign a relay output to a fan	Dry Cooler thermostat control
Pump	Use to switch on/off a pump	

Stage Inputs

Inputs can be assigned to any one of the following: -

Unused	Unused
Fan Fail N/O	Use to indicate a fan failure, 0volt return activates
Fan Fail N/C	Use to indicate a fan failure, 0volt break activates
DC Out Probe*	Dry Cooler Output probe
DC In Probe	Dry Cooler Input probe
Valve probe	Probe used to control the proportional valve. (If this is selected, the vari-output cannot be used for any other purpose)
Ambient Probe	Ambient Probe (used to change the target setpoint)
Probe (Logging)	General probe for logging (Can be aliased in the DM)
Probe (with Alarm)	General probe with alarm limits
General Fault N/O	Use to indicate a failure, 0volt return activates
General Fault N/C	Use to indicate a failure, 0volt break activates
Set Target N/O	Use to initiate a target setpoint change, 0volt return activates
Set Target N/C	Use to initiate a target setpoint change, 0volt break activates
Pump Fail N/O	Use to indicate a pump fail and change to other pump, 0volt return activates
Pump Fail N/C	Use to indicate a pump fail and change to other pump, 0volt break activates

***Note:** When inputs are being selected for the dry cooler control, the weighting is applied to the first DC probe selected. If only 1 probe; such as DC Out, is selected, no weighting will be applied.



Ensure that all power is switched off before installing or maintaining this product

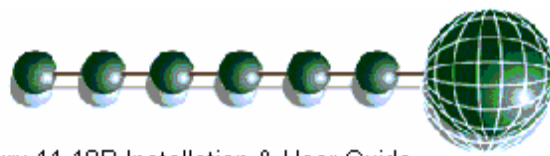

Operation

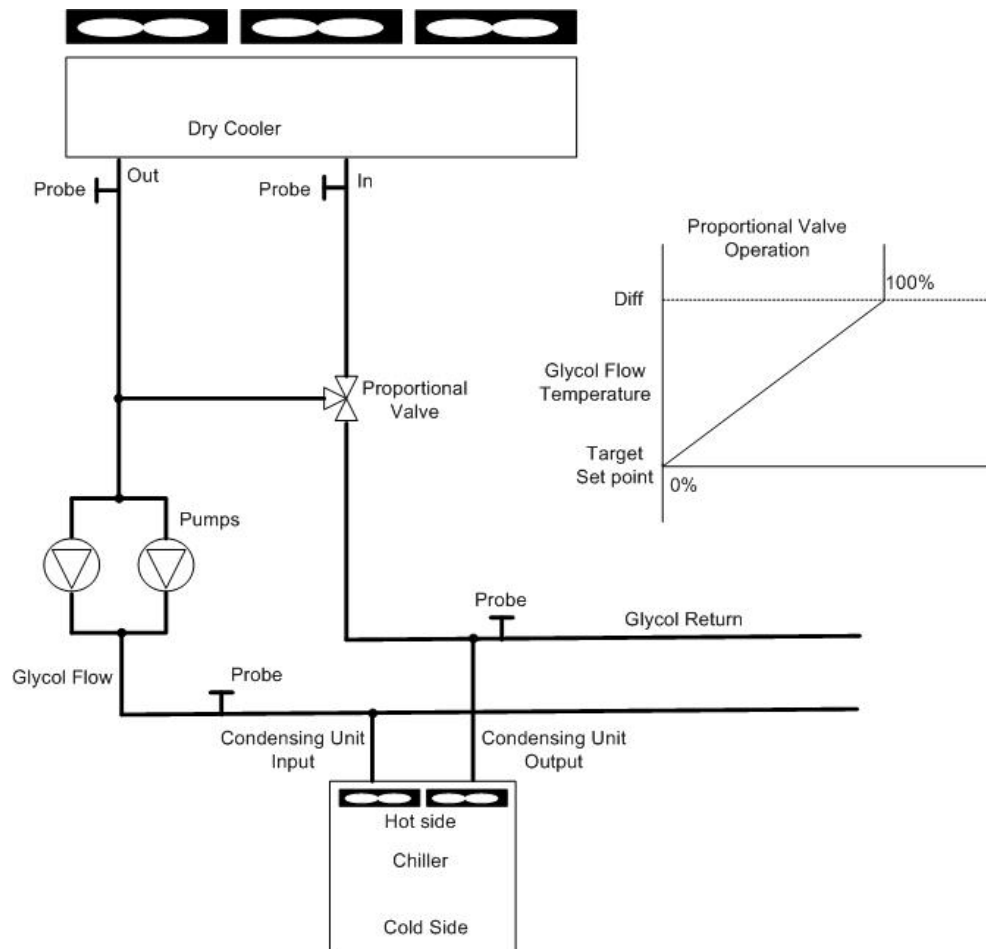

The controller can be set up for 2 thermostat functions: -

1. Control of the proportional valve via the 0-5V analogue output using the Flow (condensing unit input) probe.
2. Control of the Fans using the Dry-Cooler output probe. The fan control can be via the 0-5V analogue output, if it is not being used for thermostat 1. Or the control can be a combination of vari output and relays.

Additional probes can be selected for monitoring and alarms.

The target temperature can be offset by either the ambient probe or a digital input. The ambient probe when below its setpoint will raise the target until an "offset maximum" has been reached. The digital input will change the target to the "offset maximum". Note that both thermostat targets are changed by the same amount.

Pumps can be selected as outputs, and if a pump fail signal is detected, the other pump will start. A pump change-over schedule can be setup to even the run hours on the pumps.



Ensure that all power is switched off before installing or maintaining this product

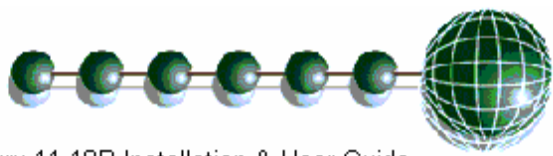

T2 Control Graph

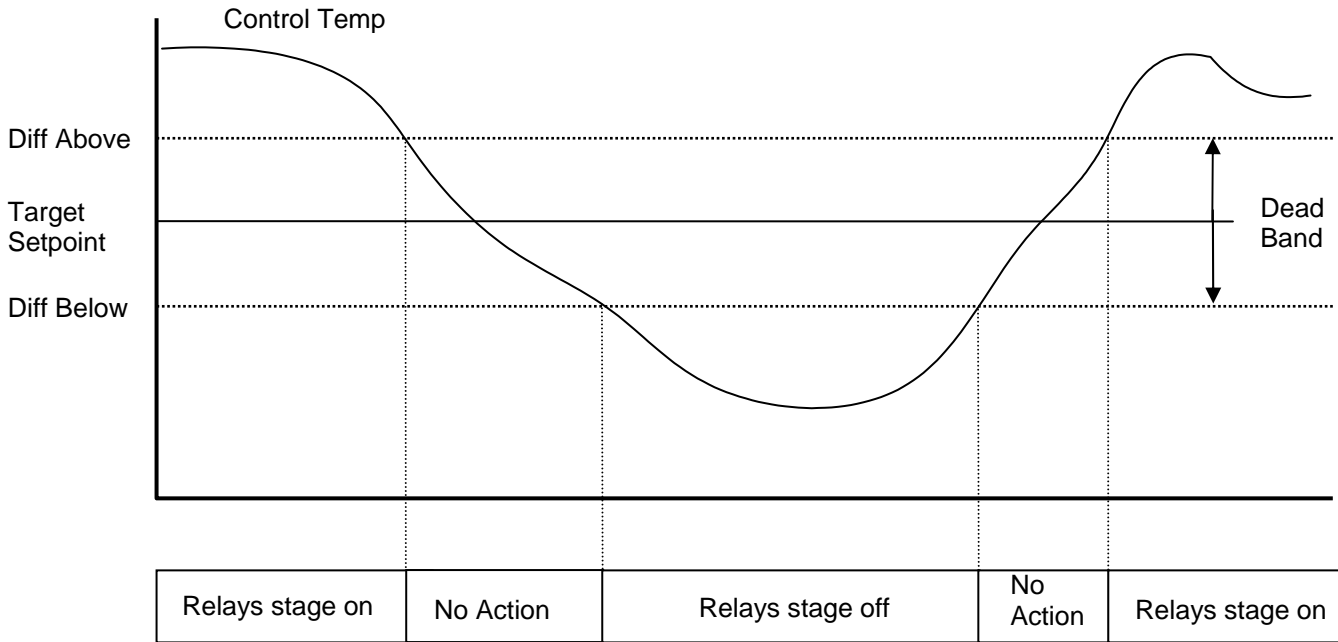

Relays Staging On Sequence with Variable Output enabled

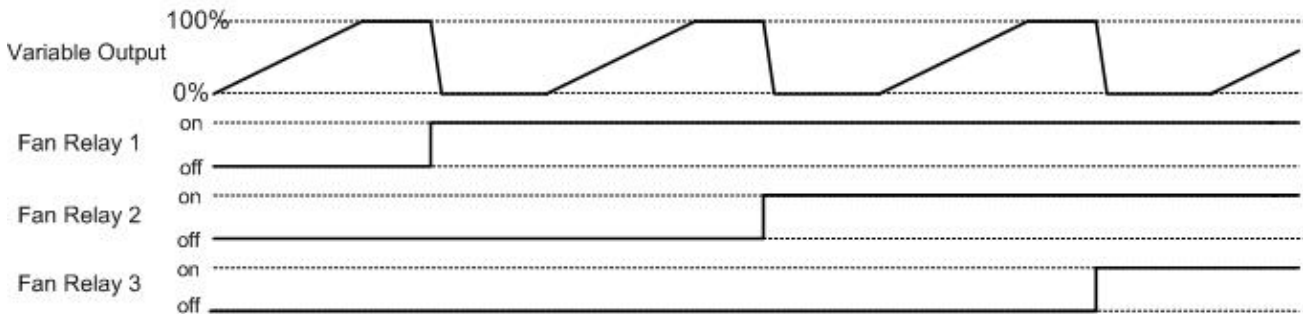

Relays Staging Off Sequence with Variable Output enabled

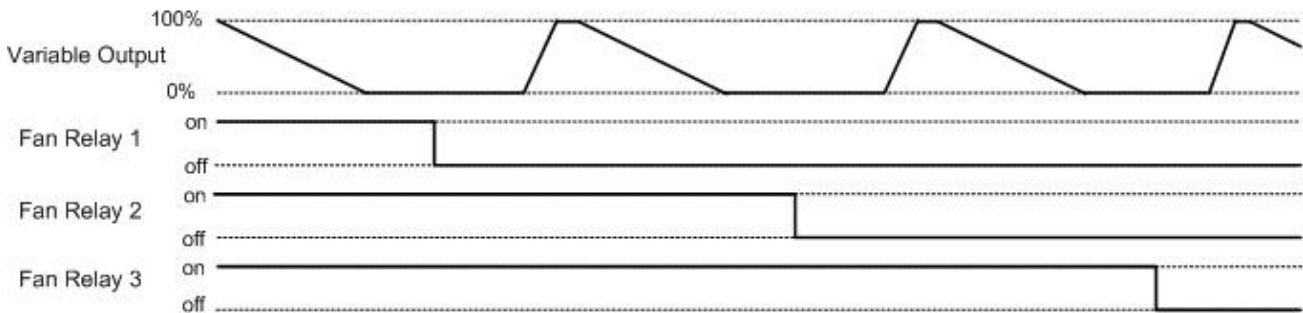

Ensure that all power is switched off before installing or maintaining this product

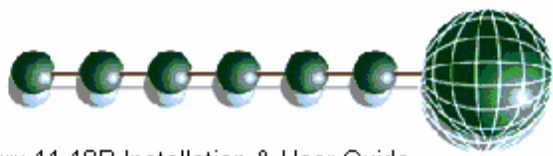

Configuration Example: -

This example shows how the controller can be configured for a Dry Cooler that has 3 fans, 2 pumps and a proportional control valve. The 2 pumps are on a 5 day change-over schedule, and have fault inputs which when active switch to the other pump. The fans are controlled by a temperature probe attached to the Dry-Cooler output pipe. The proportional valve is controlled by a temperature probe connected to the pump output pipe. An ambient probe is used to move the target temperatures (both thermostats) up as the ambient drops. There's also a digital input that moves the targets settings to the P-09 value.

Connection Table for the above example:

Physical I/O	I/O Name	Description	Alarm Action	Comments
Relay 1	Fan 1	Dry Cooler Fan 1 (N/O)	N/A	Associated with Input 1
Relay 2	Fan 2	Dry Cooler Fan 2 (N/O)	N/A	Associated with Input 2
Relay 3	Fan 3	Dry Cooler Fan 3 (N/O)	N/A	Associated with Input 3
Relay 4	Pump 1	Pump1 (N/O)		Associated with Input 4
Relay 5	Pump 2	Pump2 (N/O)		Associated with Input 5
Relay 6	Not Used			
Relay 7	Not Used			
Relay 8	Not Used			
Relay 9	Not Used			
Relay 10	Not Used			
Input 1	Fan 1 Fail	N/O fan fail circuit	Yes	Associated with relay 1
Input 2	Fan 2 Fail	N/O fan fail circuit	Yes	Associated with relay 2
Input 3	Fan 3 Fail	N/O fan fail circuit	Yes	Associated with relay 3
Input 4	Pump 1 Fail	N/O pump fail circuit	Yes	Associated with relay 4
Input 5	Pump 2 Fail	N/O pump fail circuit	Yes	Associated with relay 5
Input 6	Valve Probe	Probe that's used to control the proportional valve	Yes	
Input 7	DC Out Probe	Output of the Dry Cooler	Yes	Used as the control probe for the Fans (weighting gets ignored)
Input 8	Ambient Probe	Ambient probe	Yes	Used to change the target settings
Input 9	SN/O	Moves the target when active		
Input 9	Not Used			
Input 11	Standby	Resistor used		

Note the association between the output numbers and the input numbers. This association must be maintained for correct operation.

Example Parameters: -

Number	Parameter	Range	Step	Units	Dft	Comments
P-01	Dry Cooler Target temperature	-50 to 70	1	°C	34	Controlled by bringing fans on/off
P-02	DC Target Diff Above	0 to 30	1	°C	1	
P-03	DC Target Diff Below	0 to 30	1	°C	1	
P-04	Target offset	-50 to 70		°C	5	Used when "set target" input is activated, both targets are changed



Ensure that all power is switched off before installing or maintaining this product

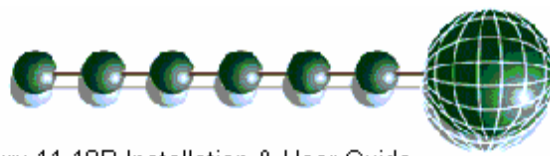

Mercury 11-10P Installation & User Guide

P-05	Control Weight	0 to 100	1	%	50	Bias to the first DC probe selected
P-06	Display Weight	0 to 100	1	%	50	Bias to the first DC probe selected
P-07	Ambient moves Target (DC & Valve)	0 = Off 1 = On	1		1	This requires an input selected as "Ambient"
P-08	Ambient Setpoint	-50 to 70	1	°C	10	Move target temperature when below this ambient. Move in proportion, 1 below, move target 1 up. Both targets are changed
P-09	Offset Maximum	0 to 30	1	°C	10	Move the target setpoint up proportionally until this offset is reached. Or move by this amount when "Move target is present)
P-10	DC Response On speed	1 - 15	1		5	1 = slowest 15 = fastest
P-11	DC Response Off speed	1 - 15	1		5	1 = slowest 15 = fastest
P-12	Valve Target Temperature (Pump output)	-50 to 70	1	°C	32	Uses the Pump Flow Temperature, and controls the variable output (Proportional valve)
P-13	Valve Response On	0 to 15	1		10	0 = slowest 15 = fastest
P-14	Valve Response Off	0 to 15	1		10	0 = slowest 15 = fastest
P-15	Cycle Pumps	0 to 10 0 = Off, Pump fail will not change pump.	1	Days	5	Set this parameter to 1 to 10 if more than 1 pump is being used.
P-16	Minimum Staging delay	00:00 to 05:00		mins/sec	00:15	Minimum delay between stage starts

Example parameters cont.....

P-17	Pressure Transducer 1	0 = off 1 = Log 2 = Log & Alarm	1		1	
P-18	Pressure Transducer 2	0 = off 1 = Log 2 = Log & Alarm	1		1	
P-19	Transducer 1 Span*	-50 - 560	1	PSI	200	Set up transducer range
P-20	Transducer 1 Offset*	-50 - 560	1	PSI	0	Setup value below 0
P-21	Transducer 2 Span*	-50 - 500	1	PSI	450	Set up transducer range



Ensure that all power is switched off before installing or maintaining this product

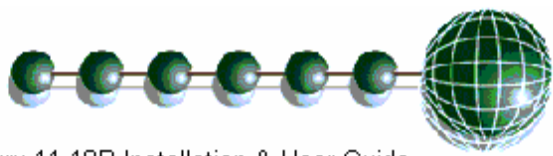

Mercury 11-10P Installation & User Guide

P-22	Transducer 2 Offset*	-50 - 500	1	PSI	0	Setup value below 0
P-30	DC OT Alarm	-42 - 60		°C	40	DC Control OT temp alarm
P-31	DC UT Alarm	-42 - 60		°C	20	DC Control UT temp alarm
P-32	Valve OT Alarm	-42 - 60		°C	40	Valve control probe OT alarm
P-33	Valve UT Alarm	-42 - 60		°C	20	Valve control Probe UT alarm
P-34	Probe OT Alarm	-42 - 60		°C	40	For inputs that been selected as probe + Alarm (PrbAlm)
P-35	Probe UT Alarm	-42 - 60		°C	5	
P-36	Transducer 1 HP Alarm	-50 - 560	1	PSI	60	Monitor with alarm
P-37	Transducer 1 LP Alarm	-50 - 560	1	PSI	4	Monitor with alarm
P-38	Transducer 2 HP Alarm	-50 - 560	1	PSI	260	Monitor with alarm
P-39	Transducer 2 LP Alarm	-50 - 560	1	PSI	100	Monitor with alarm
P-40	Fault Delay	00:00 to 60:00	1	mins/sec	00:10	
P-41	General Fault Delay	00:00 to 60:00	1	mins/sec	00:10	
P-42	Probe Alarm Delay	00:00 to 99:00	1	mins/sec	05:00	
P-43	Pressure Alarm delay	00:00 to 99:00	1	mins/sec	01:00	
P-50 ↓ P-59	Stage 1 Output Type ↓ Stage 10 Output Type	(0) None, (1) Unused, (2) Inverter (3) Fan (4) Pump	1		3 3 3 4 4 0 0 0 0 0	Fan 1 Fan 2 Fan 3 Pump 1 Pump 2 Unused Unused Unused Unused Unused
P-70 ↓ P-79	Stage 1 Input Type ↓ Stage 10 Input Type	(0) Unused (1) FanN/O (2) FanN/C (3) DC In (4) DC Out (5) Valve (6) Amb (7) PrbLog (8) PrbAlm (9) PN/O (10)PN/C (11) GN/O (12) GN/C (13) SN/O (14) SN/C	1		1 1 1 9 9 5 4 6 13 0	Fan Fail 1 Fan Fail 2 Fan Fail 3 Pump 1 Fault Pump 2 Fault Valve probe DC Out probe Ambient Probe Move Target Unused
dFLt	Restore Default Settings					



Ensure that all power is switched off before installing or maintaining this product

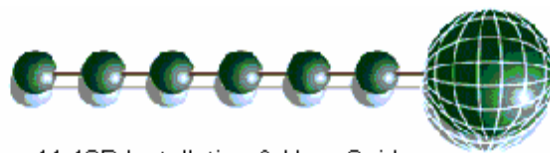

Viewing

Inputs and Outputs

Apart from setting up the controller, you can also view the status of the inputs and outputs.

1. From the function menu, select "IO", press enter
2. You can now scroll through the IO tables as set out below. The tables you view will depend on the controller type configuration.

Input/Output Table

Number	IO	Range	Units
I-01	Input 1	-50 to 70	°C
I-02	Input 2	-50 to 70	°C
I-03	Input 3	-50 to 70	°C
I-04	Input 4	-50 to 70	°C
I-05	Input 5	-50 to 70	°C
I-06	Input 6	-50 to 70	°C
I-07	Input 7	-50 to 70	°C
I-08	Input 8	-50 to 70	°C
I-09	Input 9	-50 to 70	°C
I-10	Input 10	-50 to 70	°C
I-11	Input 11	-50 to 70	°C
I-21	Status 1	0 = off, 1 = on	
I-22	Status 2	0 = off, 1 = on	
I-23	Status 3	0 = off, 1 = on	
I-24	Status 4	0 = off, 1 = on	
I-25	Status 5	0 = off, 1 = on	
I-26	Status 6	0 = off, 1 = on	
I-27	Status 7	0 = off, 1 = on	
I-28	Status 8	0 = off, 1 = on	
I-29	Status 9	0 = off, 1 = on	
I-30	Status 10	0 = off, 1 = on	
I-31	Pressure 1	-50 to 500	PSI
I-32	Pressure 2	-50 to 500	PSI
I-40	Cooler temperature	-50 to 70	°C
I-41	Valve temperature	-50 to 70	°C
O-01	Relay 1	0 = off, 1 = on	
O-02	Relay 2	0 = off, 1 = on	
O-03	Relay 3	0 = off, 1 = on	
O-04	Relay 4	0 = off, 1 = on	
O-05	Relay 5	0 = off, 1 = on	
O-06	Relay 6	0 = off, 1 = on	
O-07	Relay 7	0 = off, 1 = on	
O-08	Relay 8	0 = off, 1 = on	
O-09	Relay 9	0 = off, 1 = on	
O-10	Relay 10	0 = off, 1 = on	
O-11	DC Target temp	-50 to 70	°C
O-12	Valve Target temp	-50 to 70	°C
O-31	Variable output	0 to 100	%



Ensure that all power is switched off before installing or maintaining this product

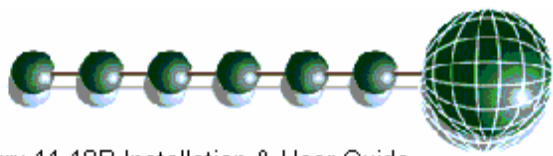

Viewing Alarms

Press the "View Alarms" button to enter this mode, the two fault LED's will flash while in this mode.

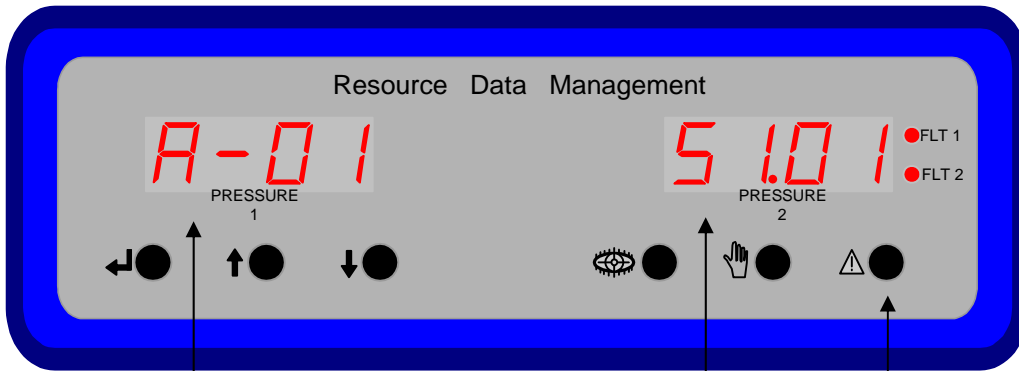

This display shows the alarm number:
E.g. Alarm 1

This display shows the alarm type:
E.g. section 1 stage 1

View Alarm button

Press the "down" button to scroll through the alarm log.
Press the "Quick View" button to see the occurred time

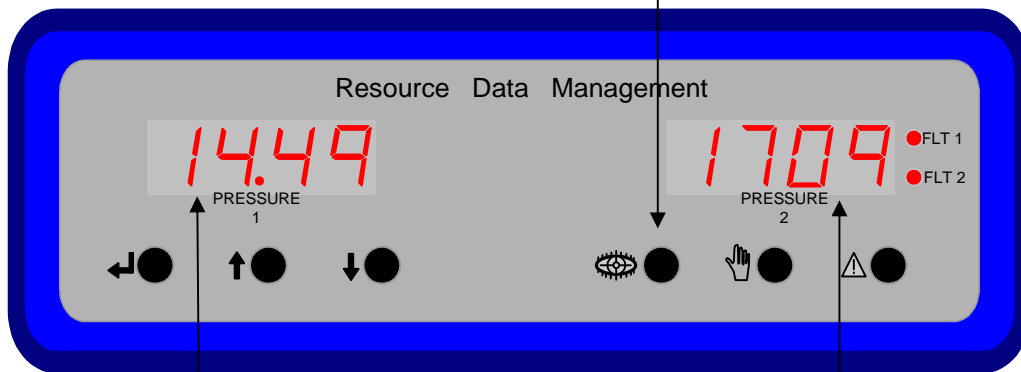

This display shows the alarm time:
E.g. 14:49

This display shows the alarm date:
E.g. 17:09(sept 17)

Press the "Quick View" button again to see the alarm "cleared" time & date.
20 alarms are held in the controller.

See [Alarm Display Messages](#) for alarm screens



Ensure that all power is switched off before installing or maintaining this product

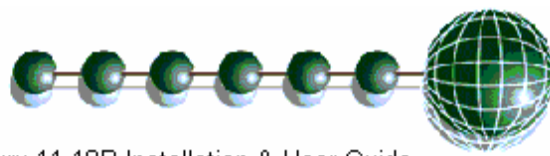

Quickview

Pressing the "quickview" button during normal operation displays the target temperature. Press the "quickview" button again to go back to the normal display or wait for the time-out period to elapse.

Override

The override function allows the user to switch output stages on or off. (Providing the output stages have been configured)

Press the override and enter button together for approx 3 secs.

Use the "up" button to turn the stage on, and the down button to turn the stage off.

Press "enter" to exit this mode or allow the time-out to elapse.

Standby Mode

The controller requires a 590 Ohm resistor present on input 11 for normal operation. If the resistor is not detected; such as in a fault condition or remote off switch, the controller will go into standby mode. All outputs will be turned off and an alarm (controller in standby) generated.

There is a 10 second delay for the detection of the resistor, both in and out.



Ensure that all power is
switched off before
installing or maintaining
this product

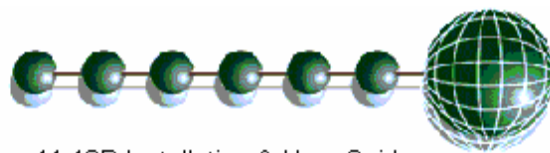

Display Messages

The following messages can appear on the Mercury display during normal operation.

Display	System status
Ft	Fault

Alarm Display Messages

The following table indicates the messages that can be displayed in the "alarm view" mode.

LH Display	RH Display	Message Description
A-nn	Ftxx	General Fault xx
A-nn	CtOt	Control temp High alarm
A-nn	CtUt	Control temp Low alarm
A-nn	FxFt	Fan fault
A-nn	PUx	Pump fault
A-nn	PrOt	Valve Probe High alarm
A-nn	PrUt	Valve Probe Low alarm
A-nn	PrFt	Valve Probe fault
A-nn	P1hP	Transducer 1 High Pressure alarm
A-nn	P1LP	Transducer 1 Low Pressure alarm
A-nn	P2hP	Transducer 2 High Pressure alarm
A-nn	P2LP	Transducer 2 Low Pressure alarm
A-nn	Ctrl	Configuration fault
A-nn	Stby	Controller in standby
no	AL	No Alarm
AL	Act	Alarm still active

Where nn = 01 to 20 (20 alarms are stored in the controller)

Where xx = 01 to 10

Where x = 0 to 9



Ensure that all power is switched off before installing or maintaining this product

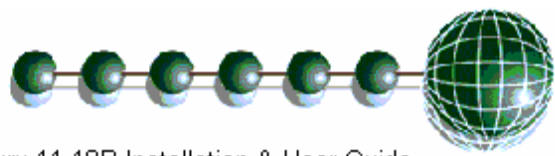

Network Alarms

The table below shows the text and associated type number that is sent to the system "front end". The type number is normally used to provide different alarm actions.

Alarm text	Type #
Valve Low Fault	6
Valve Low Temperature	5
Valve High Temperature	4
Valve Low Temperature Shutdown	10
Pump Fault	6
Fan Fault	15
Probe fault	6
General Fault n	20
Transducer n Fault	6
Transducer n Low Pressure	9
Transducer n High Pressure	8
DC Control Probe Fault	6
DC High Temperature	4
DC Low Temperature	5
DC Low Temperature Shutdown	10
Configuration Error	14
Controller in Standby	14



Ensure that all power is switched off before installing or maintaining this product

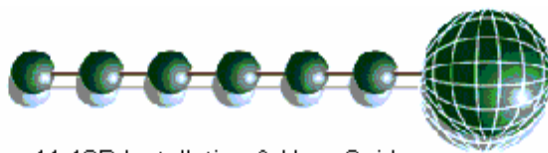

Specification

Power requirements for PR0274 and PR0276:

Supply Voltage Range:	100 - 240 Vac \pm 10%
Supply Frequency:	50 - 60 Hz \pm 10%
Maximum supply current:	<1 Amp (with no relay loads) 10 Amps (with relays 4, 5, 9 and 10 fully loaded)
Typical supply current:	<1.0 Amp
Class 2 Insulation:	No protective Earth is required and none should be fitted.

The host equipment must provide a suitable external over-current protection device such as: -
Fuse: 10A, 240 Vac Antisurge (T) HRC conforming to IEC 60127
Or MCB: 10A, 240 Vac Type C conforming to BS EN 60898

The host equipment must provide adequate protection against contact to hazardous live parts.

Power requirements for PR0275 and PR0277:

Supply Voltage Range:	10 Vdc to 35 Vdc or 15 Vac to 30 Vac
Maximum supply current:	1 Amp (Controller only)
Typical supply current:	<1.0 Amp (Controller only)
Class 2 Insulation:	The supply ground can be earthed if required.

The host equipment must provide a suitable external over-current protection device such as: -
Fuse: 3A, 240 Vac Antisurge (T) HRC conforming to IEC 60127
Or MCB: 3A, 240 Vac Type C conforming to BS EN 60898

The host equipment must provide adequate protection against contact to hazardous live parts.

General

Operating temperature range:	+5°C to +50°C
Operating Humidity:	80% maximum
Storage temperature range:	-20°C to +65°C
Environmental:	Indoor use at altitudes up to 2000m, Pollution Degree 1, Installation Category II. Voltage fluctuations not to exceed \pm 10% of nominal voltage
Size:	180mm (W) x 68mm (H) x 110mm (D)
Weight:	260 Grams
Safety:	EN61010
EMC:	EN61326; 1997 +Amdt. A1; 1998
Ventilation:	There is no requirement for forced cooling ventilation

Inputs:

Probe Input type	PT1000 for all versions
Digital Input type	0 volt return (internal pull-up resistor gives hi state when there is no return)
Comms:	RS232 with flow control
4-20mA	4-20mA current loop, use the 12 Vdc output to feed the pressure transducer

Analogue Output:

0-10Volts DC or 4-20mA, jumper selects. (see page 5 or 6)



Ensure that all power is
switched off before
installing or maintaining
this product

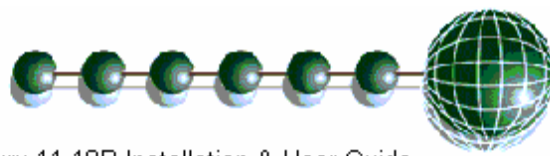

Relay Ratings

Max current relay 1: Max Voltage relay 1:	6A (non inductive) 24Vac (external supply)	Exclusive common
Max current relay 2: Max Voltage relay 2: Shared common with relay 3	4A (non inductive) 24Vac (external supply)	Relays 2 and 3 share a common supply line and the loads can have a combined total of 8A.
Max current relay 3: Max Voltage relay 3: Shared common with relay 2	4A (non inductive) 24Vac (external supply)	Relay 2 or 3 can switch a maximum of 6A provided the other is at 2A or lower.
Max current relay 4: Max Voltage relay 4:	3A (non inductive) 24Vac (external supply)	Relays 4 and 5 share a common supply line and the loads can have a combined load of 6A
Max current relay 5: Max Voltage relay 5:	3A (non inductive) 24Vac (external supply)	
Max current relay 6: Max Voltage relay 6:	6A (non inductive) 24Vac (external supply)	Exclusive common
Max current relay 7: Max Voltage relay 7: Shared common with relay 8	4A (non inductive) 24Vac (external supply)	Relays 7 and 8 share a common supply line and the loads can have a combined total of 8A.
Max current relay 8: Max Voltage relay 8: Shared common with relay 7	4A (non inductive) 24Vac (external supply)	Relay 7 or 8 can switch a maximum of 6A provided the other is at 2A or lower.
Max current relay 9: Max Voltage relay 9:	3A (non inductive) 24Vac (external supply)	Relays 9 and 10 share a common supply line and the loads can have a combined total of 6A.
Max current relay 10: Max Voltage relay 10:	3A (non inductive) 24Vac (external supply)	

Please note: The specifications of the product detailed on this set up guide may change without notice. RDM Ltd shall not be liable for errors or for incidental or consequential damages, directly or indirectly, in connection with the furnishing, performance or misuse of this product or document.



Ensure that all power is switched off before installing or maintaining this product

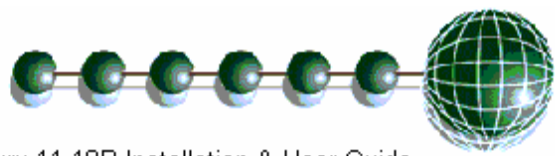

Revision History

Revision	Date	Comments
1.0		1 st draft to customer
1.1		2 nd draft to customer
1.2	22/11/2005	1 st release, part numbers changed
1.3	23/11/2005	2 nd release, added hardware connection table for the example controller
1.4	25/11/2005	3 rd release, general tidy-up + spell checked
1.5	08/03/2006	Analogue output jumper added, Part numbers changed



Ensure that all power is switched off before installing or maintaining this product