

Data Manager Installation Guide



Part Numbers: **PR0500**
 PR0510 (SSD)



Ensure that all power is switched off before installing or maintaining this product

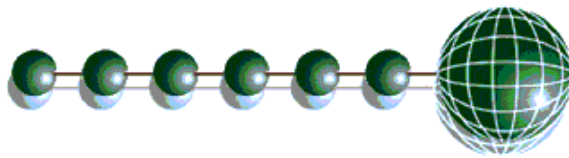
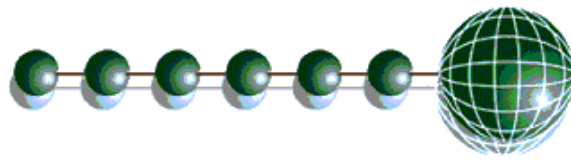

Table of Contents:

INSTALLATION	3
Description	3
Installation	3
Wall Mounting	3
Electrical Connections: -	4
USB, Ethernet, RS485 and Telephone connections.....	5
4 Port Ethernet Switch:.....	5
RS485 Connections:.....	5
Specification	6
Power requirements:	6
Relays	6
REVISION HISTORY	6
APPENDIX 1	7
Daughter Card connection detail	7
3 Relay Digital Output Expansion Board: (PR0461)	7
12 Analogue Probe Input Expansion Board: (PR0460)	8
4 x 4-20mA Input Board (PR0462).....	9
4 x 4-20mA Output Board (PR0463).....	9
4 x 0 – 5V/10V Output Board (PR0464).....	9
4 x 0 – 5V/10V Input Board (PR0465)	10
2 x 0 – 10V Input & 2 x 0 – 10V Output Board (PR0466)	10
6 x 240V Inputs – 240V Status Detect Input Board. (PR0467).....	10
APPENDIX 2	11
APPENDIX 3	12
Related Part Numbers	12



Ensure that all power is switched off before installing or maintaining this product



Installation

Description

The Data Manager is a versatile Graphic User Interface for use with RDM Mercury and 3rd Party control and monitoring equipment. The standard unit has 12 inputs that can be configured for temperature probes, plant or defrost, and 4 volt free relays.

Additional daughter boards can expand the unit, giving extra inputs (probes, plant fault and defrost) and outputs (relays). See [appendix 1](#) for daughter board details.

The Data Manager will support an IP network line, via the built-in 4 port Ethernet switch and an RS485 line, allowing for many devices to be monitored and logged. A 2x RS485 USB adapter is available for expansion to 96 RS485 devices (Two adapters would allow 160 controllers online etc). A second USB Ethernet adapter is available for connection to a second LAN or WAN.

There is an optional internal modem for alarm dial-outs and 4 USB ports for additional devices. The Data Manager also has provision for an internal battery back-up.

This wall mount unit is compact (310mm x 310mm x 80mm) and is powered by a 90-270 Vac 50/60Hz.

Installation

Wall Mounting

Outside dimensions and wall mount fixing centres: -



Use screw type: - No. 10 x 3" with suitable rawplug.

Note: The top and bottom faces of the Data Manager have a draft angle (slope). To compensate for this draft angle, shaped adapters are included so that a straight-edge can be achieved for coupling conduit.



Ensure that all power is switched off before installing or maintaining this product

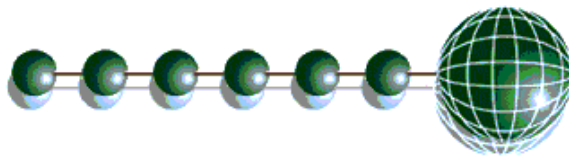

Electrical Connections: -

Remove the left and right side panels by unscrewing the 4 bolts on the side plates and easing the side plates off. There is a screwdriver slot located on the side of each plate to aid removal; use a flat blade screwdriver to lever the plates. Once the side plates have been removed, power and input/output connections are available. (Note that these will vary according to your configuration; see [appendix 1](#) for daughter card detail)

Knock-outs are provided on the top, bottom and back for cable entry.

This unit meets the European EMC standards for immunity and radiation, if the location of the device is such that there is a high level of electrical noise (spike, surges or dips); it is recommended that either a surge suppressor or UPS is fitted to the unit.

Front View with sides removed, no daughter cards fitted

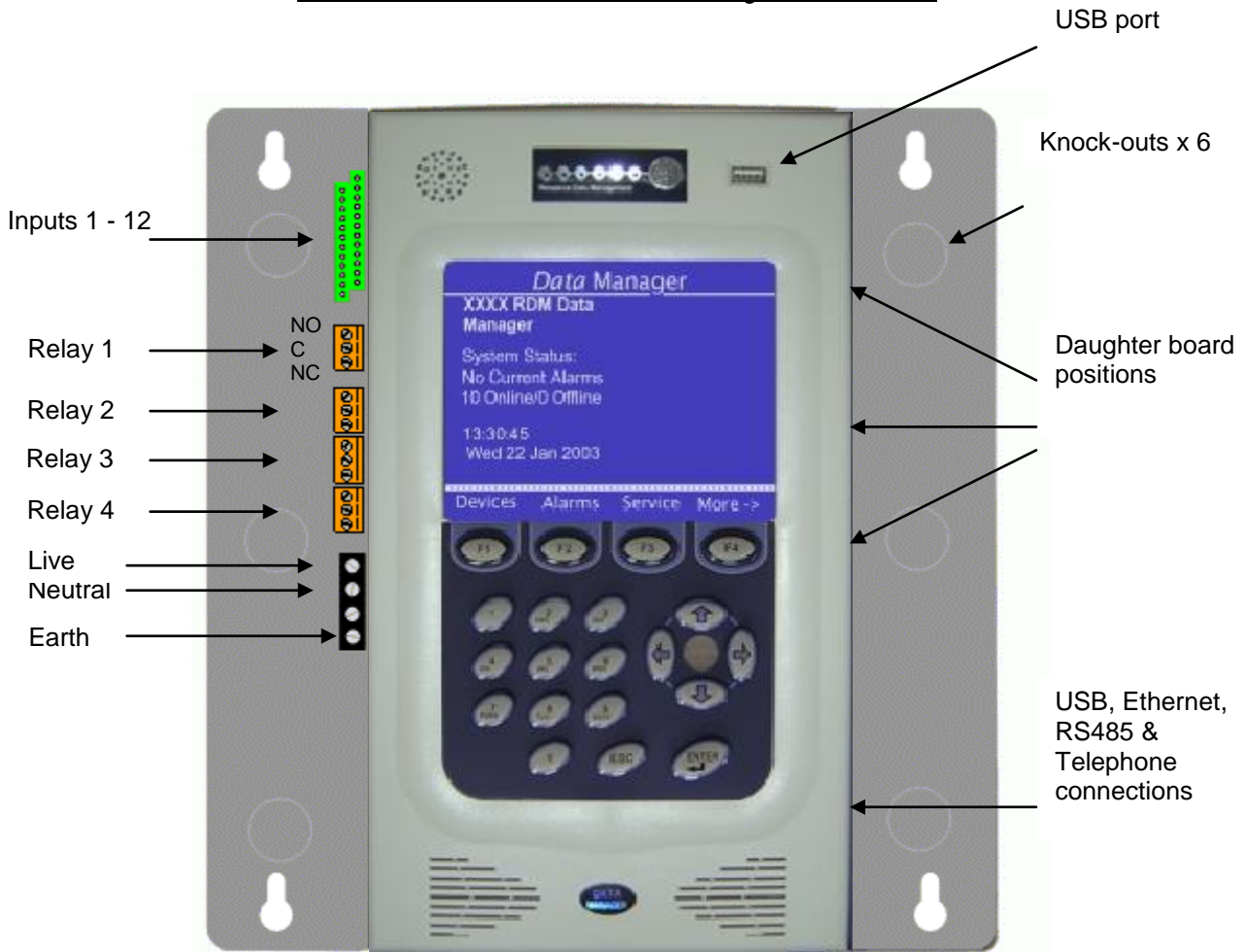

Probe connections:	lower tier: -	Probe Grounds
	Upper tier: -	Probe inputs

Plant and Defrost:	Lower tier: -	Grounds (0V)
	Upper tier: -	Ground (0V) return inputs

Supply: 100 - 240 Vac 50/60 Hz

Once the wiring is complete, the two front covers should be replaced and secured by the 4 screws on the front.

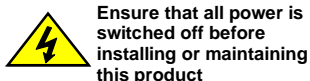

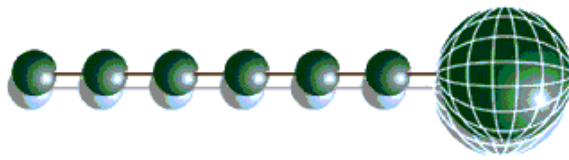

USB, Ethernet, RS485 and Telephone connections

The connections for the following devices are on the right hand side of the Data Manager – remove the wing for access:

- 4 x USB ports
- 4 x Ethernet 10/100baseT ports
- 1 x Telephone port (for internal modem; if fitted)
- 1 x RS485 Port

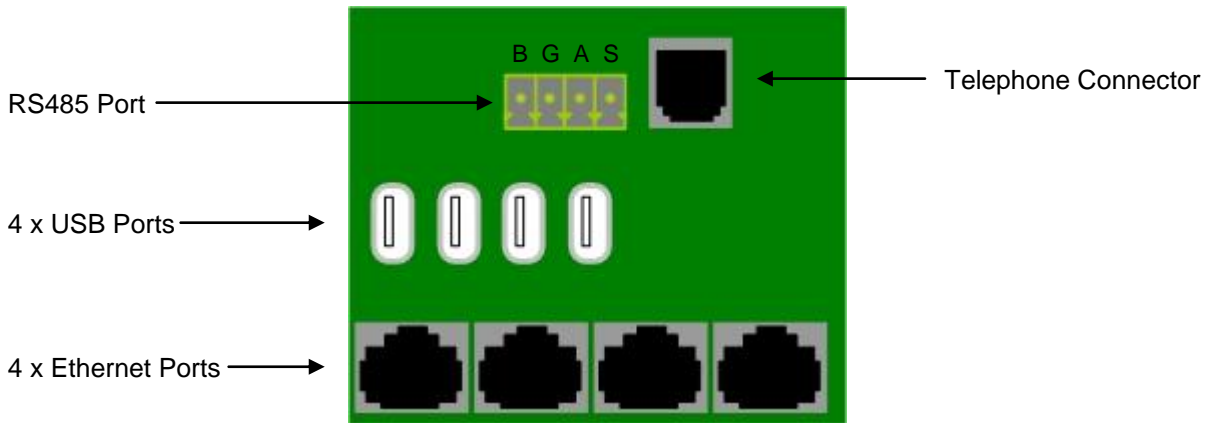

4 Port Ethernet Switch:

There is a green and yellow LED associate to each of the 4 ports.

The green LED when static, indicates that the connection to the device is good, the green LED then flickers when data is being transmitted.

When the yellow LED is off it indicates a 10 BaseT connection. When the yellow LED is on it indicates a 100 BaseT connection

RS485 Connections:

S = screen
A = Data +
G = Ground
B = Data -



Ensure that all power is switched off before installing or maintaining this product

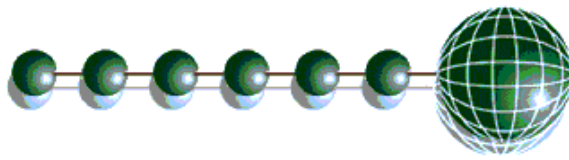

Specification

Power requirements:

Supply Voltage Range:	100 - 240 Vac \pm 10%
Supply Frequency:	50 - 60 Hz
Maximum supply current:	1 Amps
Typical supply current:	<1 Amp
Operating temperature range:	+5°C to +30°C
Operating Humidity:	80% maximum
Storage temperature range:	-20°C to +65°C
Environmental:	Indoor use at altitudes up to 2000m, Pollution Degree 1, Installation Category II. Voltage fluctuations not to exceed \pm 10% of nominal voltage
Size:	310mm (W) x 325mm (H) x 95mm (D)
Weight:	2360 Grams *
Safety:	EN61010
EMC:	EN61326; 2002
Ventilation:	There is no requirement for forced cooling ventilation
Class 2 Insulation:	This unit must be Earthed

The host equipment must provide a suitable external over-current protection device such as: -

Fuse:	1A 240 Vac Antisurge (T) HRC conforming to IEC 60127
Or MCB:	1A, 240 VAC Type C conforming to BS EN 60898

* Weight is dependent on the DM configuration as some items are optional.

Relays

Fixed on-board relays:	7.5A resistive load 250Vac COS ϕ =0.4 5A inductive load 250Vac
------------------------	--

Daughter board relays, See [Appendix 1](#)

Revision History

Revision	Date	Changes
6.0		New keypad, new IO board, front page image updated, wall mounting image updated, electrical connections image updated, IO board image updated, onboard relay data updated to include inductive load specification, part numbers table updated to list latest items.
6.1		Additional information relating to 4 port Ethernet switch included, 6 Input 240V Status board included, Battery backup text modified, part number table updated.



Ensure that all power is switched off before installing or maintaining this product

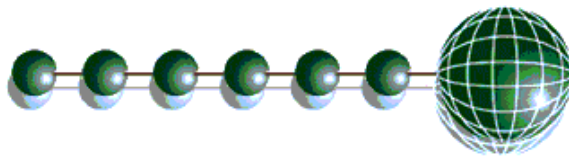

Appendix 1

Daughter Card connection detail

3 Relay Digital Output Expansion Board: (PR0461)

Relay boards have 3 x volt free relays, In order to conform to the Low Voltage Directive, some configurations of voltages are not allowed - see table 1 below.

Table 1	Low Voltage on: -	High Voltage on: -
Allowed Configurations:	RL1, RL2, RL3	
		RL1, RL2, RL3
	RL1	RL2, RL3
	RL2, RL3	RL1
Disallowed Configurations:	RL1, RL2	RL3
	RL2	RL1, RL3
	RL3	RL1, RL2

Low Voltage defined as < 35 V

High voltage defined as >110 V

All 3 relays are rated at 5A/250V~/AC1

Contact connection detail is shown below: -

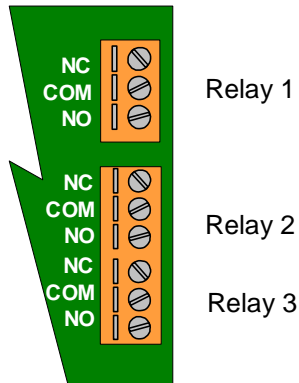

Ensure that all power is switched off before installing or maintaining this product

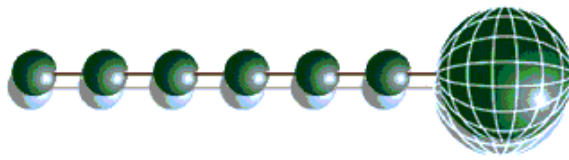

12 Analogue Probe Input Expansion Board: (PR0460)

This board has 12 analogue inputs; each input can be configured (setup option) as a Temperature probe, Plant or Defrost input.
A variety of temperature probe options are available: -

PT1000
NTC 470
NTC 700
NTC 2K
NTC 2K25
NTC 3K
NTC 5K
NTC 100K

Connection detail is shown below

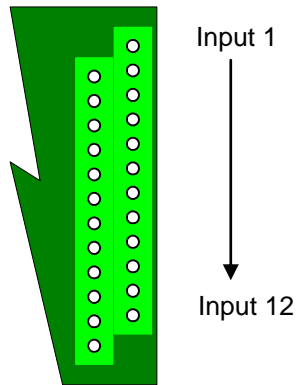

Probe connectors: lower tier: - Probe Grounds (0V)
 upper tier: - Probe inputs

Plant and Defrost: Lower tier: - Grounds (0V)
 Upper tier: - Ground (0V) return input



Ensure that all power is
switched off before
installing or maintaining
this product

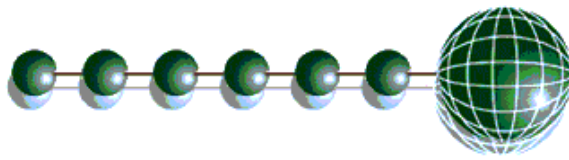

4 x 4-20mA Input Board (PR0462)

This board has 4 independent 4-20mA inputs. There is a +12 V DC output to feed the external device.

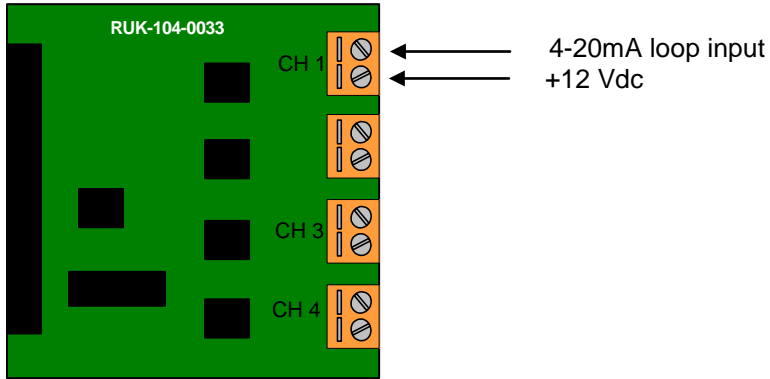

4 x 4-20mA Output Board (PR0463)

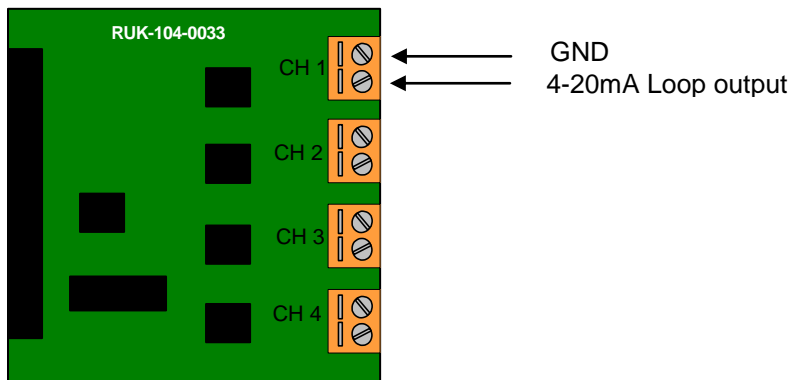

4 x 0 – 5V/10V Output Board (PR0464)

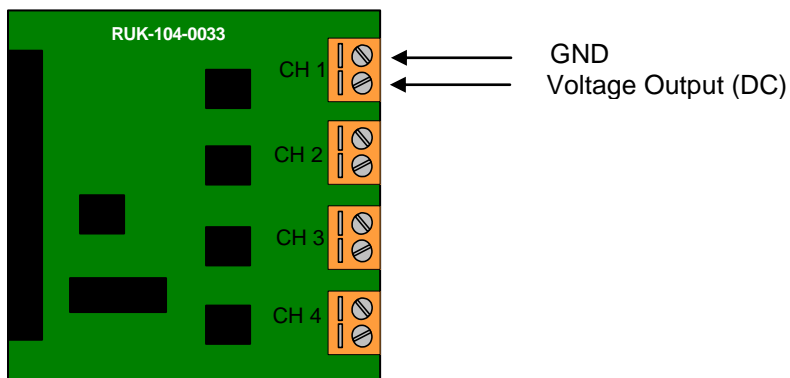

Ensure that all power is switched off before installing or maintaining this product

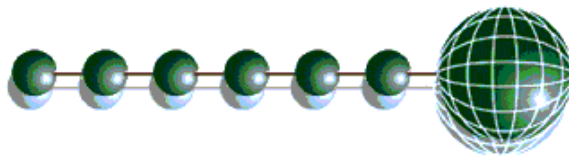

4 x 0 – 5V/10V Input Board (PR0465)

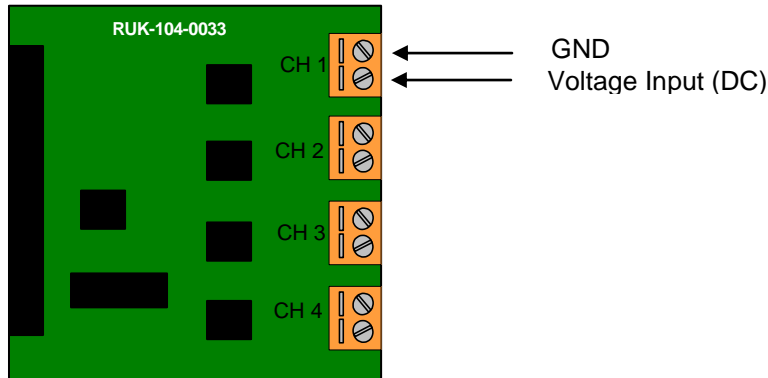

2 x 0 – 10V Input & 2 x 0 – 10V Output Board (PR0466)

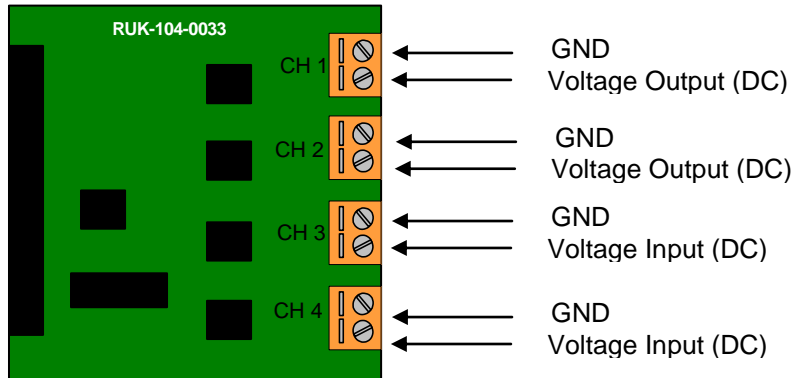

6 x 240V Inputs – 240V Status Detect Input Board. (PR0467)

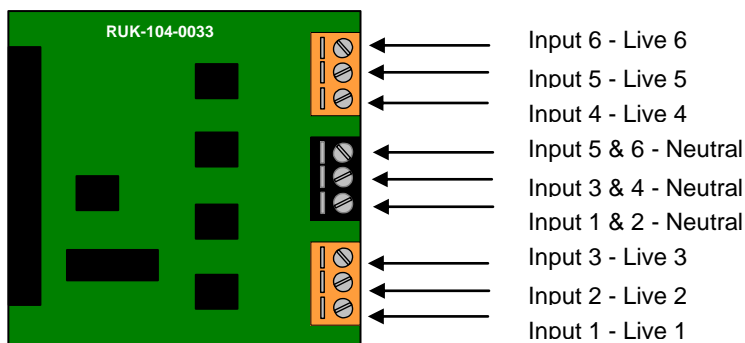

All inputs are rated to 240Vac.

Note all Neutral connections are common as they are link on the PCB.

Note: Products PR0462, PR0463, PR0464, PR0465 and PR0466 are suitable for use only with the Data Builder.



Ensure that all power is switched off before installing or maintaining this product

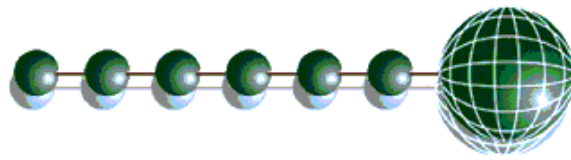

Appendix 2

Installation of internal Battery Back-up for Data Manager

Before working on this equipment, ensure that the device is fully isolated from any supply voltage, including connections to all relays and other I/O connectors.

Installation of this part must be carried out by competent personnel.

RDM will not be held responsible for any damage incurred to the equipment through mishandling or faulty installation of this part.

Instructions:

1. Remove the left side wing by unscrewing the 2 bolts at the top and bottom.
2. Before removing the battery and charger board from its' packaging, make sure that you are static free. Connect the battery + terminal (red) to the red + lead of the charger board, Connect the battery - terminal (black) to the Black - lead of the charger board.
3. Slide the battery into its compartment and slide the charger PCB into the guides making sure the leads do not snag. Once the battery and charger board are in place, connect the 6 way interconnecting cable to it's mating connector on the charger board.
4. That's it, the installation is complete. Re-assemble the left side wing and secure it with the 2 bolts.
5. The battery will take between 10 and 14 hours to fully charge.

RDM recommend that the battery from the on-board battery backup is replaced once a year.

Please note if the Data Manager has a battery backup kit fitted and the Data Manager is being transported then the battery must be removed from the Data Manager and fitted in the cardboard retaining filler which ships with the Data Manager to prevent damage during transit.



Ensure that all power is switched off before installing or maintaining this product

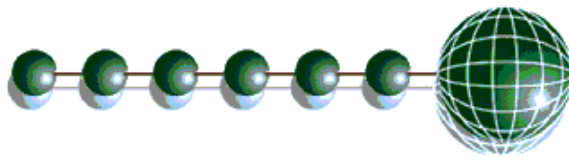

Appendix 3

Related Part Numbers

Hardware Related Part Numbers		USB 3 track card reader kit with DM wing cover	PR0493
DM Base model with on board PSU	PR0500	DM 4 Port hub I/O board upgrade kit	PR0459
DM Base model with on board PSU & SDD	PR0510	Data Manager GSM Modem	PR0496
On-board modem	PR0491		
On-board battery back up	PR0492	Software Related Part Numbers	
12 Analogue probe input expansion card	PR0460	Energy Saving - Optimisation Features Only	PR0474
3 Relay digital output expansion card	PR0461	Energy Saving - Network Trim Heaters Control Features only	PR0475
4 x 4 - 20mA Input expansion card	PR0462	Energy Saving - Night Blinds Features only	PR0476
4 x 4 - 20mA Output expansion card	PR0463	Energy Saving - Condenser TD Features only	PR0477
4 x 0 - 5 or 0 - 10 Volt Output expansion card	PR0464	Energy Saving - Performance Features only	PR0478
4 x 0 - 5 or 0 - 10 Volt Input expansion cards	PR0465	Energy Saving - Defrost Warning Features only	PR0479
2 x 0-10 V Input & 2 x 0-10 V Output	PR0466	Modbus Interface Enabler	PR0470
6 Input (240V Status)	PR0467	BACnet Interface Enabler	PR0471
485 Genus compatible network	PR0480	Data Manager software upgrade to latest version	DMSWUPG
IP network. Each 32 devices	PR0481	Wireless Mesh Software Enabler	PR0735
485 USB dongle for 2 x 32 devices	PR0482		
The Data Builder	PR0485		
The Data Builder Lite	PR0485-LITE		
Secondary IP Interface	PR0486		
ActiveFM	PR0487		



Ensure that all power is switched off before installing or maintaining this product